



31810

UNDERCARRIAGE KIT

Ford F-150 4X4

1997 - 04

Ford F-250 LD 4X4

1997 - 99

Installation Instructions

⚠ CAUTION

Read this document before installing the snowplow.

⚠ CAUTION

See your BLIZZARD® outlet/Web site for specific vehicle application recommendations before installation. The Undercarriage Selection Guide has specific vehicle and snowplow requirements.

SAFETY

SAFETY DEFINITIONS

⚠ WARNING

Indicates a potentially hazardous situation that, if not avoided, could result in death or serious personal injury.

⚠ CAUTION

Indicates a potentially hazardous situation that, if not avoided, may result in minor or moderate injury. It may also be used to alert against unsafe practices.

NOTE: Indicates a situation or action that can lead to damage to your snowplow and vehicle or other property. Other useful information can also be described.

WARNING/CAUTION & INSTRUCTION LABELS

Become familiar with and inform users about the warning and instruction labels on the back of the blade.

NOTE: If labels are missing or cannot be read, see your sales outlet.



POWER PLOW® and SPEEDWING™ Blades Only (both sides)

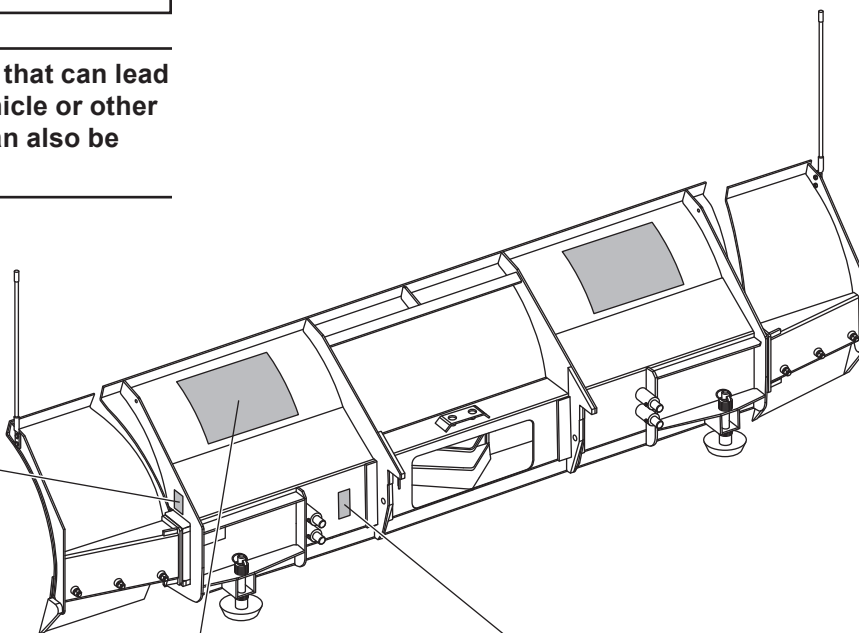

ATTACH	⚠ WARNING: Keep fingers away from snowplow and truck attachment points. POWER HITCH™ arm raises behind undercarriage pushbeam.	DETACH
<ol style="list-style-type: none"> Slowly drive vehicle forward to engage mount adapter into A-frame. Turn power switch to center or "OFF" position. Plug in electrical harnesses. Push and hold power switch RIGHT and push UP and hold arm/blade operation switch. Arm will engage mount adapter and pull snowplow towards vehicle. Install both hitch pins. Hitch pin is fully engaged when pin handle is against the pin guide plate. While holding power switch RIGHT, push DOWN and hold arm/blade operation switch. Arm will disengage mount adapter to relieve tension on the stand. Pull and raise the stand until the stand pin seats into upper hole on the A-frame. Turn power switch to left or "Flowing" position. 	<p>ATTACH - Steps 2, 4, 6 & 8 DETACH - Steps 2, 3, 5 & 7</p> <p>ATTACH - Step 5 DETACH - Step 6</p> <p>Read Owner's Manual for Complete Instructions.</p>	<ol style="list-style-type: none"> Lower snowplow onto ground with blade straight. Turn plow control in cab to "OFF" position. Turn power switch to center or "OFF" position. While holding the power switch RIGHT, push DOWN and hold the arm/blade operation switch. Arm will disengage mount adapter to relieve tension on the stand. Pull and lower the stand until stand pin seats into lower hole on the A-frame and stand and light tower side plates contact. Push and hold power switch RIGHT and push UP the arm/blade operation switch. Arm will engage mount adapter and pull snowplow tightly to vehicle. Remove both hitch pins. While holding power switch RIGHT, push DOWN and hold arm/blade operation switch to fully lower arm. Unplug electrical harnesses.
<p>U.S. Patents 5,420,480; 5,638,618; 5,899,007; 6,178,669; 6,263,470; 6,276,076; 6,383,737; 6,408,549; 6,412,199; 6,442,877; 6,615,513; 7,134,227; RE 35,700; 48208 CAN Patents 2,061,425; 2,194,922; 2,220,743; 2,250,508; 2,355,145; 2,358,354; 2,466,195; and other patents pending.</p>		

SAFETY

SAFETY PRECAUTIONS

Improper installation and operation could cause personal injury and/or equipment and property damage. Read and understand labels and the Owner's Manual before installing, operating or making adjustments.

⚠ WARNING

Lower blade when vehicle is parked. Temperature changes could change hydraulic pressure, causing the blade to drop unexpectedly or damaging hydraulic components. Failure to do this could result in serious personal injury.

⚠ WARNING

The driver shall keep bystanders clear of the blade when it is being raised, lowered or angled. Do not stand between the vehicle and the blade or within 8 feet of a moving blade. A moving or falling blade could cause personal injury.

⚠ WARNING

Keep hands and feet clear of the blade and A-frame when mounting or removing the snowplow. Moving or falling assemblies could cause personal injury.

⚠ WARNING

Do not exceed GVWR or GAWR including the blade and ballast. The rating label is found on the driver-side vehicle door cornerpost.

⚠ WARNING

To prevent accidental movement of the blade, always turn the ON/OFF switch to OFF whenever the snowplow is not in use. The control indicator light will turn off.

⚠ WARNING

Remove blade assembly before placing vehicle on hoist.

⚠ CAUTION

Refer to the Undercarriage Selection Guide for minimum vehicle recommendations and ballast requirements.

PERSONAL SAFETY

- Remove ignition key and put the vehicle in park or in gear to prevent others from starting the vehicle during installation or service.
- Wear only snug-fitting clothing while working on your vehicle or snowplow.
- Do not wear jewelry or a necktie, and secure long hair.
- Wear safety goggles to protect your eyes from battery acid, gasoline, dirt and dust.
- Avoid touching hot surfaces such as the engine, radiator, hoses and exhaust pipes.
- Always have a fire extinguisher rated BC handy, for flammable liquids and electrical fires.

FIRE AND EXPLOSION

⚠ WARNING

Gasoline is highly flammable and gasoline vapor is explosive. Never smoke while working on vehicle. Keep all open flames away from gasoline tank and lines. Wipe up any spilled gasoline immediately.

Be careful when using gasoline. Do not use gasoline to clean parts. Store only in approved containers away from sources of heat or flame.

CELL PHONES

A driver's first responsibility is the safe operation of the vehicle. The most important thing you can do to prevent a crash is to avoid distractions and pay attention to the road. Wait until it is safe to operate Mobile Communication Equipment such as cell phones or two-way radios.

VENTILATION

⚠ WARNING

Vehicle exhaust contains lethal fumes. Breathing these fumes, even in low concentrations, can cause death. Never operate a vehicle in an enclosed area without venting exhaust to the outside.

www.storksplows.com
TORQUE SPECIFICATIONS

TORQUE CHART

⚠ CAUTION

Read instructions before assembling. Fasteners should be finger tight until instructed to tighten according to the torque chart. Use standard methods and practices when attaching snowplow including proper personal protective safety equipment.



Grade Identification for J429-Grade 5 Bolt



Grade Identification for J429-Grade 8 Bolt

SAE J429 Grade 5 Torque Values				SAE J429 Grade 8 Torque Values			
Nominal Thread Size	Clamp Loads (lb)	Tightening Torque		Nominal Thread Size	Clamp Loads (lb)	Tightening Torque	
		"Lubricated"	"Dry"			"Lubricated"	"Dry"
1/4-20	2,000	6 ft-lb	8 ft-lb	1/4-20	2,850	9 ft-lb	12 ft-lb
5/16-18	3,350	13 ft-lb	18 ft-lb	5/16-18	4,700	18 ft-lb	25 ft-lb
3/8-16	4,950	23 ft-lb	31 ft-lb	3/8-16	6,950	32 ft-lb	44 ft-lb
7/16-14	6,800	37 ft-lb	50 ft-lb	7/16-14	9,600	53 ft-lb	70 ft-lb
1/2-13	9,050	57 ft-lb	75 ft-lb	1/2-13	12,800	80 ft-lb	107 ft-lb
9/16-12	11,600	82 ft-lb	109 ft-lb	9/16-12	16,400	115 ft-lb	154 ft-lb
5/8-11	14,500	113 ft-lb	151 ft-lb	5/8-11	20,300	159 ft-lb	211 ft-lb
3/4-10	21,300	200 ft-lb	266 ft-lb	3/4-10	30,100	282 ft-lb	376 ft-lb
7/8-9	29,435	321 ft-lb	430 ft-lb	7/8-9	41,550	454 ft-lb	606 ft-lb
1-8	38,600	482 ft-lb	640 ft-lb	1-8	54,540	680 ft-lb	900 ft-lb



Grade Identification for Metric-Grade 8.8 Bolt



Grade Identification for Metric-Grade 10.9 Bolt

Metric Class 8.8 Torque Values				Metric Class 10.9 Torque Values			
Diameter (mm)	Clamp Loads (lb)	Tightening Torque		Diameter (mm)	Clamp Loads (lb)	Tightening Torque	
		"Lubricated"	"Dry"			"Lubricated"	"Dry"
5	1,389	3 ft-lb	5 ft-lb	5	1,987	5 ft-lb	7 ft-lb
6	1,965	6 ft-lb	8 ft-lb	6	2,812	8 ft-lb	11 ft-lb
7	2,826	10 ft-lb	13 ft-lb	7	4,044	14 ft-lb	19 ft-lb
8	3,579	14 ft-lb	19 ft-lb	8	5,121	20 ft-lb	27 ft-lb
10	5,672	28 ft-lb	37 ft-lb	10	8,116	40 ft-lb	53 ft-lb
12	8,243	49 ft-lb	65 ft-lb	12	11,796	70 ft-lb	92 ft-lb
14	11,246	77 ft-lb	103 ft-lb	14	16,092	111 ft-lb	148 ft-lb
16	15,882	125 ft-lb	167 ft-lb	16	21,970	173 ft-lb	231 ft-lb
18	19,423	172 ft-lb	229 ft-lb	18	26,868	238 ft-lb	317 ft-lb
20	24,784	244 ft-lb	325 ft-lb	20	34,284	338 ft-lb	450 ft-lb

www.storksplows.com
UNDERCARRIAGE INSTALLATION

INSTALLATION INSTRUCTIONS

NOTE: For easier assembly and installation, vehicle and all snowplow components should be on a smooth, level, hard surface, such as concrete.

1. Remove the bumper, with brackets attached, and tow hooks from the vehicle frame.
2. If necessary, remove the skid plate and save the parts for reinstallation if the mount is removed from the vehicle.
3. Place the mount frame against the driver-side vehicle rail and attach to the tow hook holes using existing hardware. Verify the mount frame is tight against the bottom of the vehicle frame.

⚠ CAUTION

Use caution not to pinch, cut or drill through any wires or hoses running along the frame rails.

4. The larger bottom hole at the back of the mount frame should line up with the top slot on the vehicle frame. Ream this hole to 5/8". Above that, drill two 1/2" holes on each side, using the rear mount frame brackets as a template.

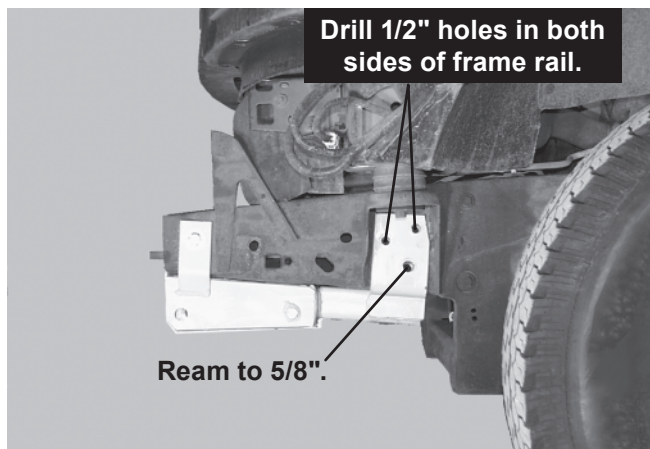

5. Install a nut bar inside each frame rail, aligning it with the drilled holes. Fasten each rear mount frame bracket to the nut bar with a 5/8" x 1-1/2" cap screw, lock washers and two 1/2" x 1-1/2" cap screws and lock washers.
6. Using the front mount frame brackets as templates, drill a 1/2" hole through the outer and inner wall of each side of the vehicle frame. Insert the U-bracket into the frame and align with the drilled holes. Insert a 1/2" x 1-3/4" cap screw through the holes in the frame sides and U-bracket. Secure with 1/2" locknuts.

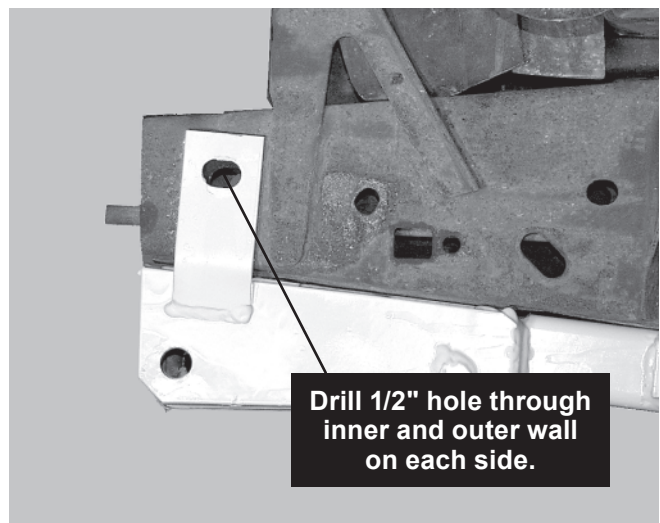

7. Repeat Steps 3–6 for the passenger's side.
8. Tighten all fasteners according to the torque chart.
9. Reinstall the bumper to the original position using existing fasteners.
10. The air deflector will require notching for clearance of the mount receivers, or it may be removed from the vehicle. If reinstalling the deflector, use existing fasteners. If the deflector is removed from the vehicle, save the deflector and fasteners for reinstallation in the event the undercarriage kit is removed from the vehicle.

NOTE: After five to ten hours of snowplow usage, retorque all undercarriage assembly fasteners.

www.storksplows.com
UNDERCARRIAGE INSTALLATION

MOUNT ADAPTER MEASUREMENT

11. With the vehicle on level ground, measure from the ground to the center of the hole on the U-bracket side plate on the mount.

The height of the mount should be 14-1/4" or less from the center of the U-bracket hole to level ground. If the mount is higher than 14-1/4", the enclosed adapter plates need to be attached to the mount adapter. (The mount adapter comes packaged with the blade crate assembly.)

If the measured height is 14-1/4" or less, no height adjustment adapter plates are needed.

If the measured height is higher than 14-1/4", install the short height adjustment adapter plates as described.

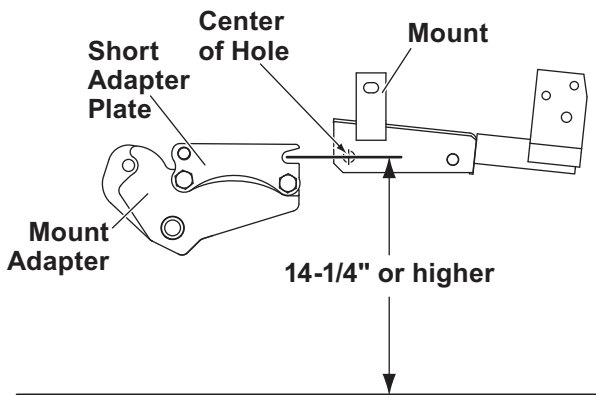

MOUNT ADAPTER INSTALLATION

Install adapter plates as follows:

1. Position the adapter plate against the driver's side portion of the mount adapter as shown. Insert a 3/4" x 2-3/4" cap screw through the lower front adapter plate hole and through the appropriate hole on the mount adapter. Secure with a locknut.

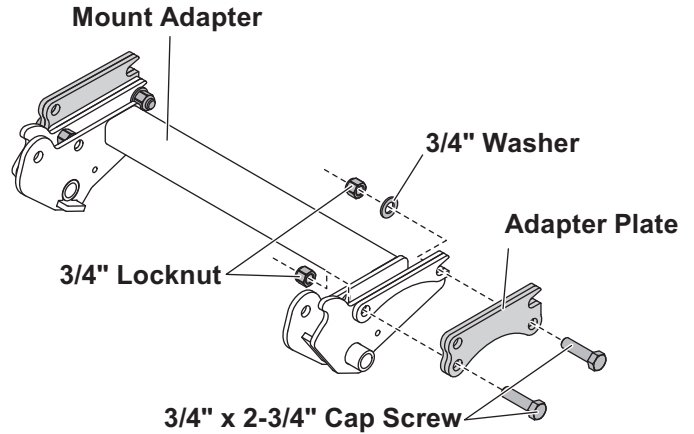

2. Insert a cap screw through the rear adapter plate hole, through the slot on the mount adapter and through a washer. Secure with a locknut.
3. Repeat for the passenger's side. Tighten all fasteners according to the torque chart.

NOTE: After five to ten hours of snowplow usage, retorque all undercarriage assembly fasteners.



Blizzard
PO Box 245038
Milwaukee, WI 53224-9538
www.blizzardplows.com

 A DIVISION OF DOUGLAS DYNAMICS, L.L.C.

Blizzard reserves the right under its product improvement policy to change construction or design details and furnish equipment when so altered without reference to illustrations or specifications used. Blizzard or the vehicle manufacturer may require or recommend optional equipment for snow removal. Do not exceed vehicle ratings with a snowplow. Blizzard offers a limited warranty for all snowplows and accessories. See separately printed page for this important information. The following are registered (®) or unregistered (™) trademarks of Douglas Dynamics, L.L.C.: BLIZZARD®, POWER HITCH™, POWER HITCH™ 2, POWER PLOW®, SPEEDWING™.

Printed in U.S.A.