



Western Products
 PO Box 245038
 Milwaukee, WI 53224-9538
 www.westernplows.com

A DIVISION OF DOUGLAS DYNAMICS, LLC

43088 – MVP 3™ Blades

SHOE KIT

Parts List & Installation Instructions

PARTS LIST

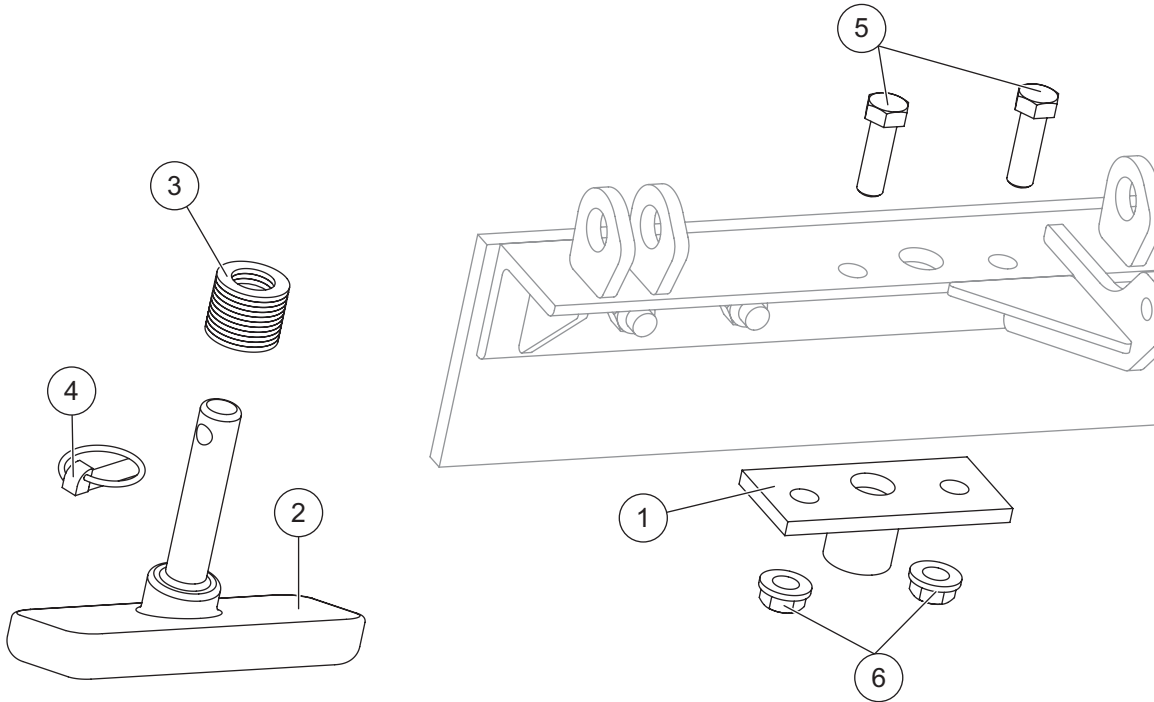

43088 Shoe Kit MVP 3							
Item	Part	Qty	Description	Item	Part	Qty	Description
1	29743	2	Shoe Bracket	4	93010K	1	7/16 x 1-3/4 Linchpin (pkg of 2)
2	50695	2	Shoe – Rectangle, Solid Cast	ns	50697	1	Bolt Bag
3	91192	18	Flat Washer, Special				
50697 Bolt Bag							
5		4	5/8-11 x 2 Hex Cap Screw G5	6		4	5/8-11 Hex Flange Locknut GC
ns = not shown				G = Grade			

⚠ WARNING
 Do not exceed GVWR or GAWR, including blade and ballast. The rating label is found on the driver-side vehicle door cornerpost.

⚠ CAUTION
 Use standard methods and practices when attaching snowplow and installing accessories, including proper personal protective safety equipment.

⚠ CAUTION
 Read this document before installing the Shoe Kit.

⚠ CAUTION
 See your WESTERN® outlet/Web site for specific vehicle application recommendations before installation. Shoe Kit weight information may be found in the Quick Match tool.

43088 SHOE KIT

INSTALLATION INSTRUCTIONS

1. Park the vehicle on a smooth, level, hard surface, such as concrete. Raise the blade, then turn the control OFF.
2. From the side of the blade assembly, place jack stands or sturdy blocking under the T-frame.
3. Turn the control ON and lower the blade onto the jack stands or blocking. Turn the control OFF. Turn the vehicle ignition to the "OFF" position and remove the key.
4. Orient the shoe bracket so the bracket holes align with the holes in the base angle.

NOTE: All three holes in the bracket must line up with the three holes in the base angle.

5. Insert a 5/8" x 2" cap screw through each of the two outer holes in the shoe bracket and base angle. Attach a 5/8" locknut and tighten to 150 ft-lb.

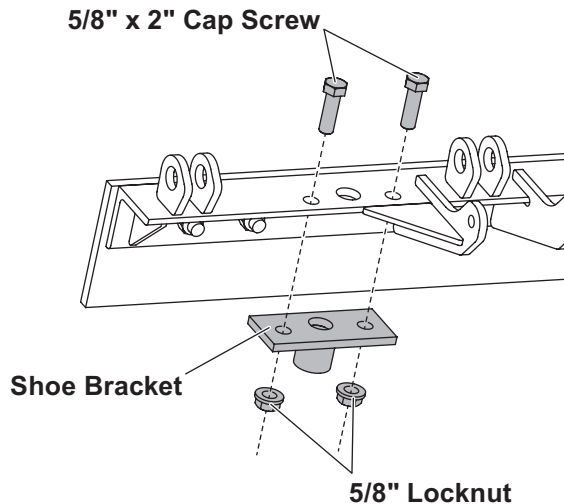

6. Repeat for the opposite side.

Copyright © 2014 Douglas Dynamics, LLC. All rights reserved. This material may not be reproduced or copied, in whole or in part, in any printed, mechanical, electronic, film or other distribution and storage media, without the written consent of Western Products. Authorization to photocopy items for internal or personal use by Western Products outlets or snowplow owner is granted.

Western Products reserves the right under its product improvement policy to change construction or design details and furnish equipment when so altered without reference to illustrations or specifications used. Western Products or the vehicle manufacturer may require or recommend optional equipment for snow removal. Do not exceed vehicle ratings with a snowplow. Western Products offers a limited warranty for all snowplows and accessories. See separately printed page for this important information. The following are registered (®) or unregistered (™) trademarks of Douglas Dynamics, LLC: MVP 3™, UltraMount® 2, WESTERN®.

7. Determine the desired height of the cutting edge from the ground. Place the appropriate number of flat washers on the shoe and insert it up through the center hole in the shoe bracket and base angle. Secure with a linchpin.

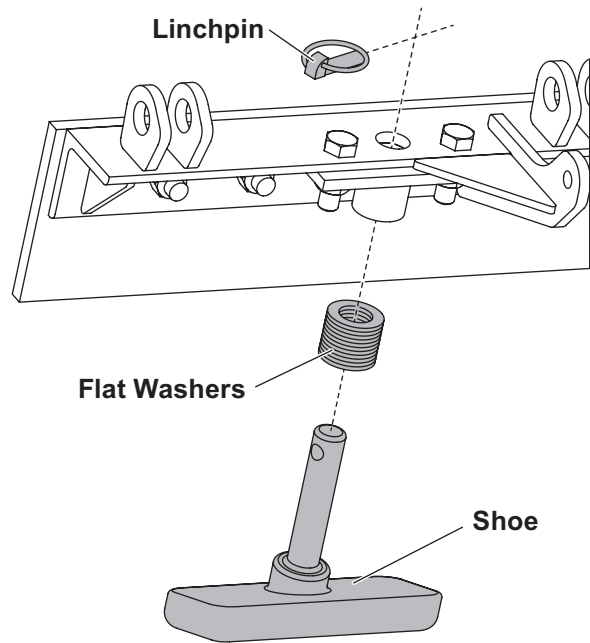

8. Repeat for the opposite side.