



Western Products
PO Box 245038
Milwaukee, WI 53224-9538
www.westernplows.com

DD A DIVISION OF DOUGLAS DYNAMICS, LLC

43116

T-Frame Service Kit

Installation Instructions

INSTALLATION INSTRUCTIONS

⚠ WARNING

Do not exceed GVWR or GAWR, including blade and ballast. The rating label is found on the driver-side vehicle door cornerpost.

⚠ CAUTION

Read this document before installing the T-Frame Service Kit.

⚠ CAUTION

Use standard methods and practices when attaching snowplow and installing accessories, including proper personal protective safety equipment.

Pushbeam Installation

1. Park the vehicle on a smooth, level, hard surface, such as concrete. Lower the blade to the ground, and turn the control to the "OFF" position. Disconnect the snowplow from the vehicle, or turn the vehicle ignition to the "OFF" position and remove the key.
2. Align the front holes in the pushbeam with the front holes in the T-frame. Loosely fasten with two 3/4" x 2-1/2" carriage bolts* and 3/4" locknuts.

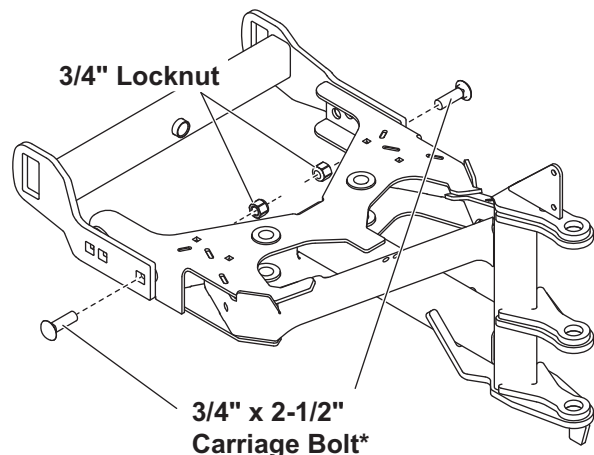

3. Align the rear holes in the pushbeam with the rear holes in the T-Frame and fasten in the middle position using two 3/4" x 2-1/2" carriage bolts* and 3/4" locknuts. Tighten until assembly is secure, but do not torque at this time.

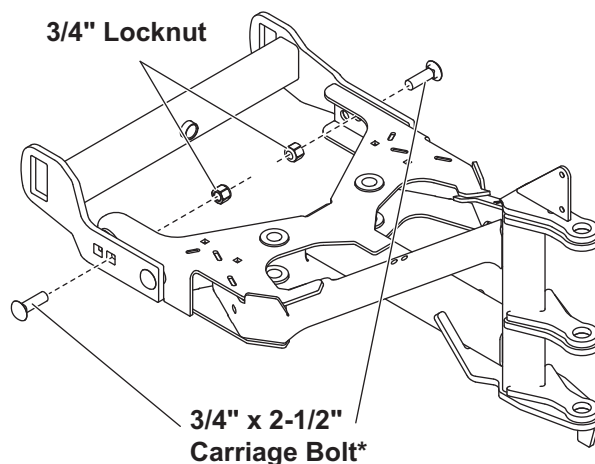

4. Assemble the rest of the snowplow.
5. Check that the T-frame is parallel with the ground as described in Step 1 under "Leveling Adjustment Procedure."

* 3/4-10 x 2-1/2 Hex Cap Screws (PN 90459) are required when attaching the T-frame to a push assembly with round holes instead of square holes.

Leveling Adjustment Procedure

1. With the snowplow attached to a properly ballasted vehicle and the blade lowered to the ground, the T-frame should be parallel with the ground.

If the T-frame is parallel with the ground, go to Step 4.

If the T-frame is not already parallel with the ground, place the snowplow in the scoop position and follow Steps 2–4.

2. Loosen the front fasteners connecting the pushbeam to the T-frame, but do not remove them. Next, remove the rear fasteners connecting the pushbeam to the T-frame. Level the T-frame so its parallel with the ground.

3. Select the hole in the rear of the T-frame that is aligned closest to the rear holes in the pushbeam. Reassemble the previously removed fasteners into the rear holes.

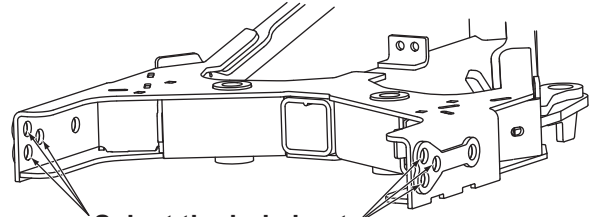

4. Lubricate and tighten all fasteners to 250 ft-lb.

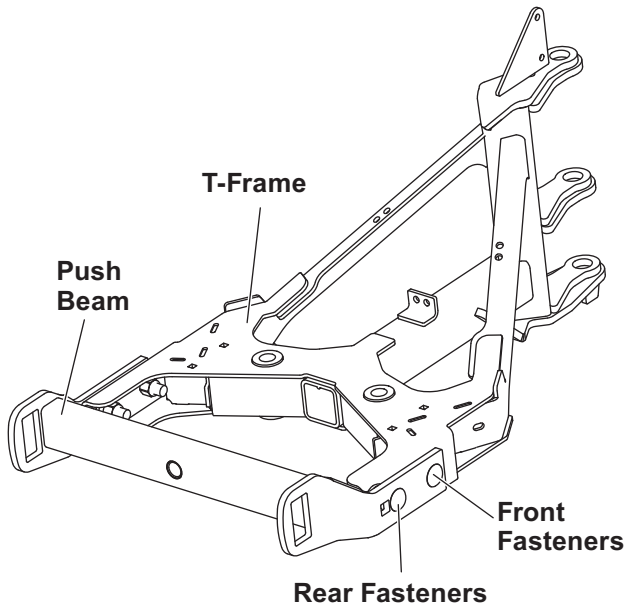

Western Products reserves the right under its product improvement policy to change construction or design details and furnish equipment when so altered without reference to illustrations or specifications used. Western Products or the vehicle manufacturer may require or recommend optional equipment for snow removal. Do not exceed vehicle ratings with a snowplow. Western Products offers a limited warranty for all snowplows and accessories. See separately printed page for this important information. The following are registered (®) or unregistered (™) trademarks of Douglas Dynamics, LLC: UltraMount® 2, WESTERN®.

Printed in U.S.A.