



85201
Spreader Components
WB-160D Walk-Behind Drop Spreader
Parts List

This Parts List is for WESTERN® WB-160D walk-behind drop spreaders with serial numbers 0000 and higher.

WB-160D WALK-BEHIND DROP SPREADER

HOPPER COMPONENTS

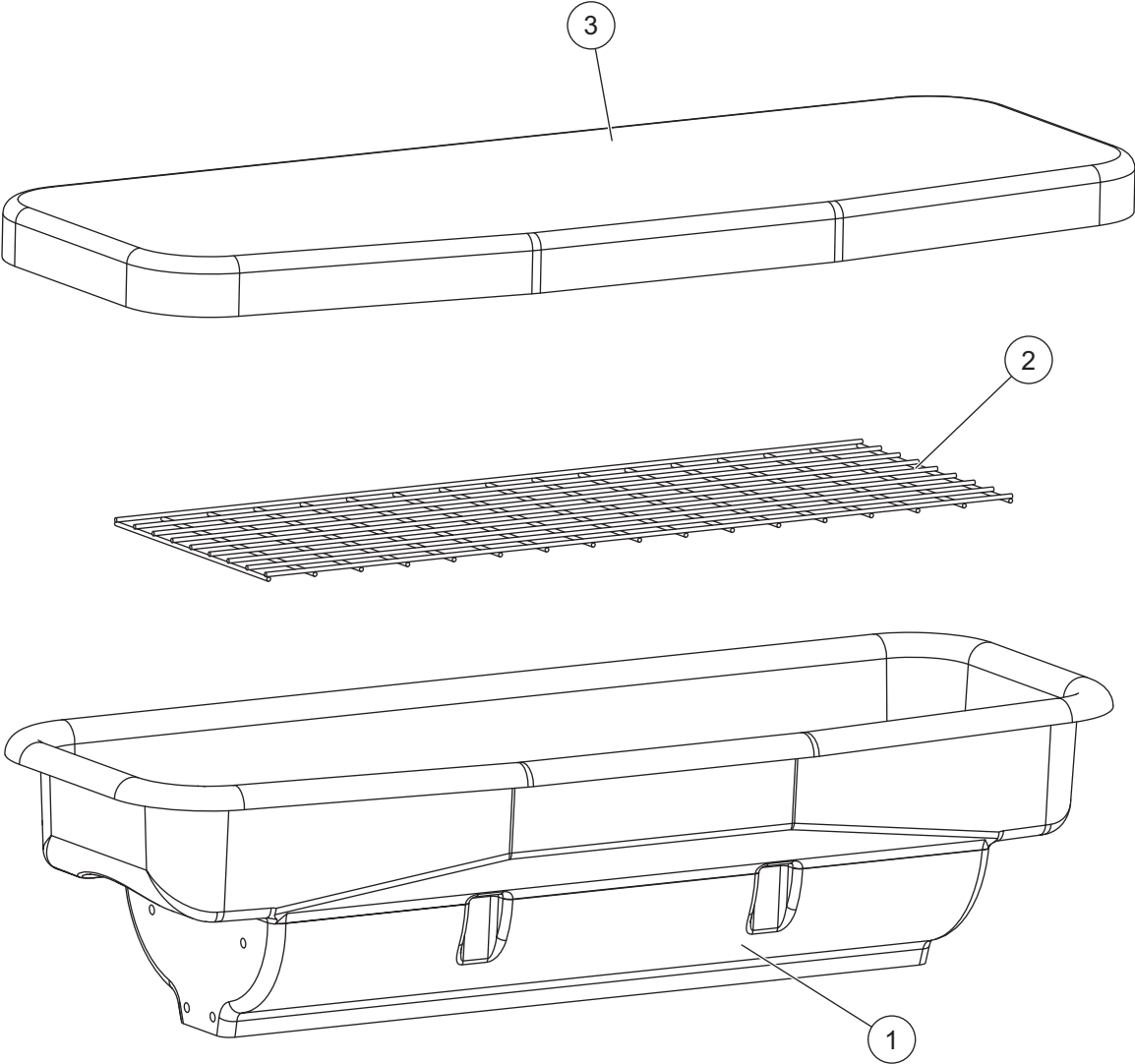

WB-160D WALK-BEHIND DROP SPREADER

Hopper Components							
Item	Part	Qty	Description	Item	Part	Qty	Description
1	51014	1	Hopper, WB-160D Red	3	50993	1	Hopper Cover, WB-160D
2	50989	1	Top Screen, WB-160D				

WB-160D WALK-BEHIND DROP SPREADER

MAIN FRAME ASSEMBLY

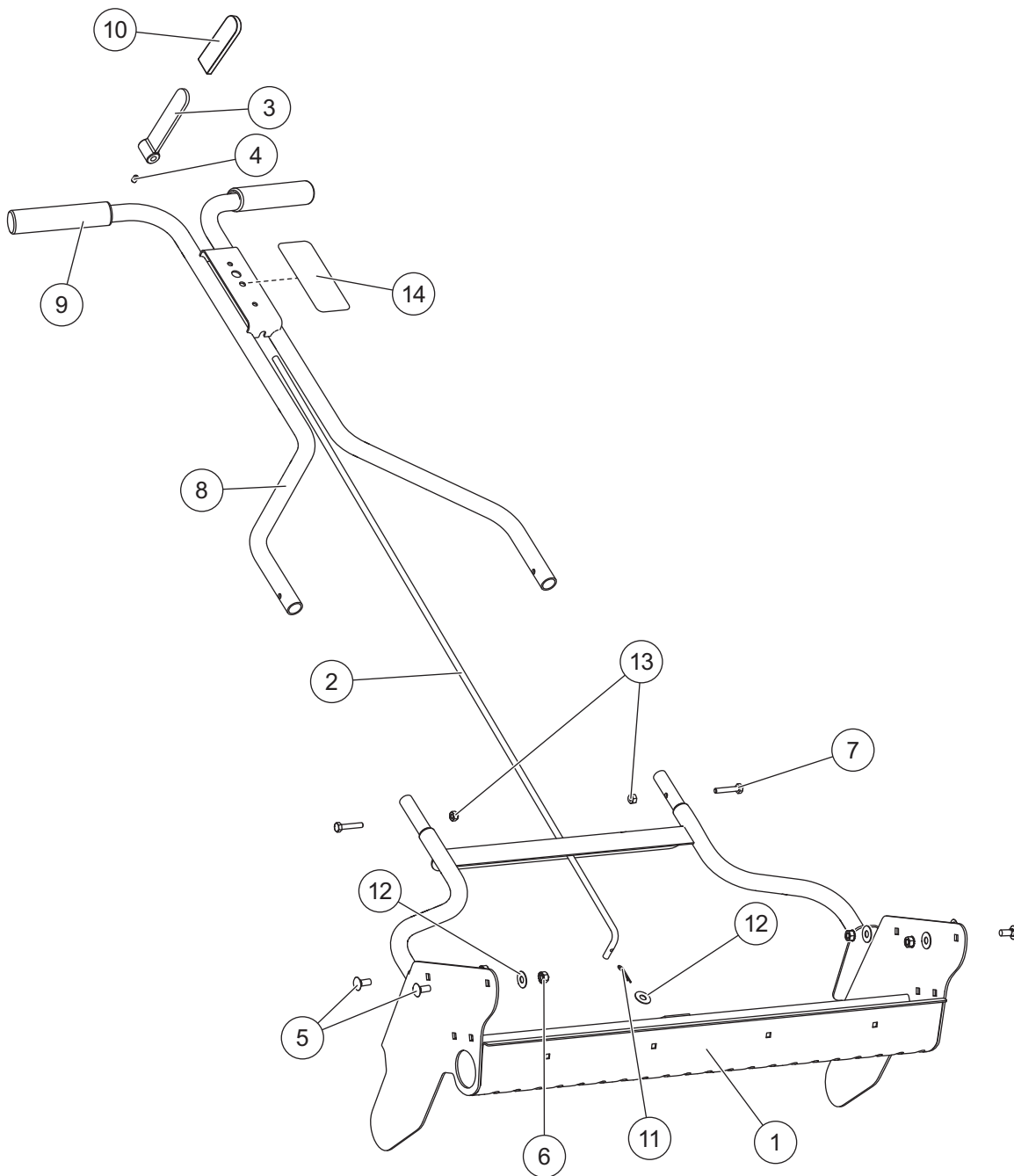

WB-160D WALK-BEHIND DROP SPREADER

Main Frame Assembly							
Item	Part	Qty	Description	Item	Part	Qty	Description
1	50983	1	Main Frame WB-160D	10	50940	1	Handle Cover
2	50985	1	Actuator Rod	11	50953	1	0.0585 x 1-1/8 Hairpin Cotter SS
3	88272	1	Gate Lever	12	51009	5	5/16 Flat Washer SS
4	88273	1	1/4-20 x 3/8 Sprocket Set Screw	13	50970	2	1/4-20 Hex Locknut Waxed SS
5	50994	4	5/16-18 x 3/4 Carriage Bolt SS	14	51013	1	Label, Open/Close
6	50995	4	5/16-18 Nut w/Ext Tooth Lock Washer SS	ns	50979	1	Handle Hardware Kit WB-160D
7	50911	2	1/4-20 x 1-3/8 Hex Cap Screw SS	ns	69812	1	Label, Serial Number
8	50912	1	Push Spreader Handle	ns	50980	1	Gate Lever Hardware Kit WB-160D
9	50917	2	Handle Grip				
50979 Handle Hardware Kit WB-160D							
7	50911	2	1/4-20 x 1-3/8 Hex Cap Screw SS	13	50970	2	1/4-20 Hex Locknut Waxed SS
50980 Gate Lever Hardware Kit WB-160D							
3	88272	1	Gate Lever	11	50953	1	0.0585 x 1-1/8 Hairpin Cotter SS
4	88273	1	1/4-20 x 3/8 Sprocket Set Screw	12	51009	1	5/16 Flat Washer SS
10	50940	1	Handle Cover				
ns = not shown				SS = Stainless Steel			

WB-160D WALK-BEHIND DROP SPREADER

AXLE ASSEMBLY

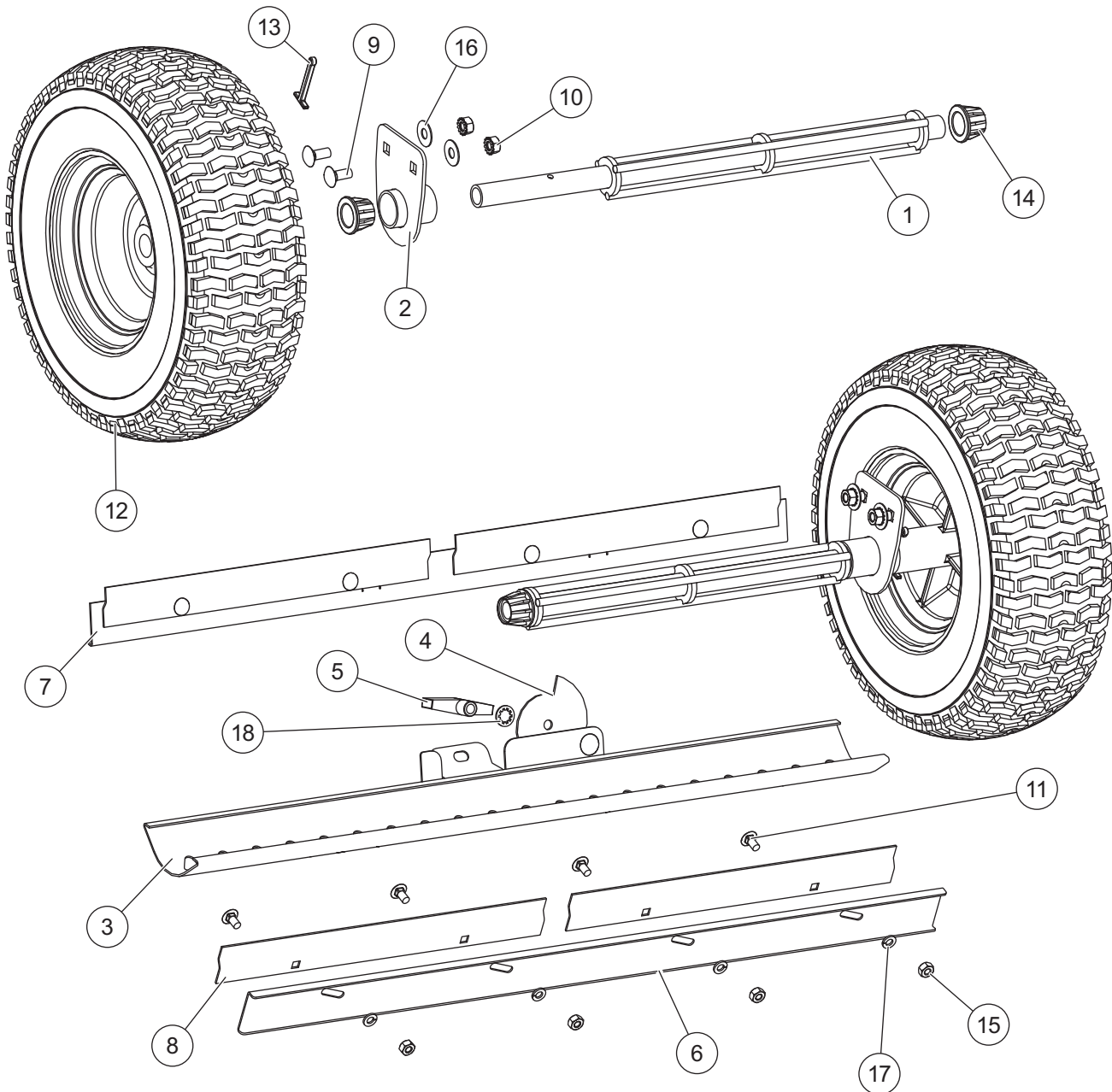

WB-160D WALK-BEHIND DROP SPREADER

Axle Assembly							
Item	Part	Qty	Description	Item	Part	Qty	Description
1	50982	2	Agitator Axle	10	50995	4	5/16-18 Nut w/Ext Tooth Lock Washer SS
2	50984	2	Bearing Bracket WB-160D	11	50996	8	1/4-20 x 1/2 Carriage Bolt SS
3	50986	1	Gate Slide WB-160D	12	50907	2	13" x 5" Wheel
4	50987	1	Calibration Cam	13	50933	2	3/16 x 2 Cotter Pin SS
5	50988	1	Knob WB-160D	14	50935	4	Wheel Bushing Nylon
6	50990	1	Gate Tension Adjustment Bracket	15	51008	8	1/4-20 Hex Locknut SS
7	50991	1	Gate Mount Bracket	16	51009	4	5/16 Flat Washer SS
8	50992	4	Clamp Cleat	17	51010	8	1/4 Flat Washer SS
9	50994	4	5/16-18 x 3/4 Carriage Bolt SS	18	51011	1	3/8 Lock Washer Int Tooth SS

SS = Stainless Steel

www.storksplows.com
WB-160D WALK-BEHIND DROP SPREADER

Copyright © 2013 Douglas Dynamics, LLC. All rights reserved. This material may not be reproduced or copied, in whole or in part, in any printed, mechanical, electronic, film or other distribution and storage media, without the written consent of Western Products. Authorization to photocopy items for internal or personal use by Western Products outlets or spreader owner is granted.

Western Products reserves the right under its product improvement policy to change construction or design details and furnish equipment when so altered without reference to illustrations or specifications used. Western Products offers a limited warranty for all spreaders and accessories. See separately printed page for this important information. The following is a registered (®) trademark of Douglas Dynamics, LLC: WESTERN®.

Printed in U.S.A.
