

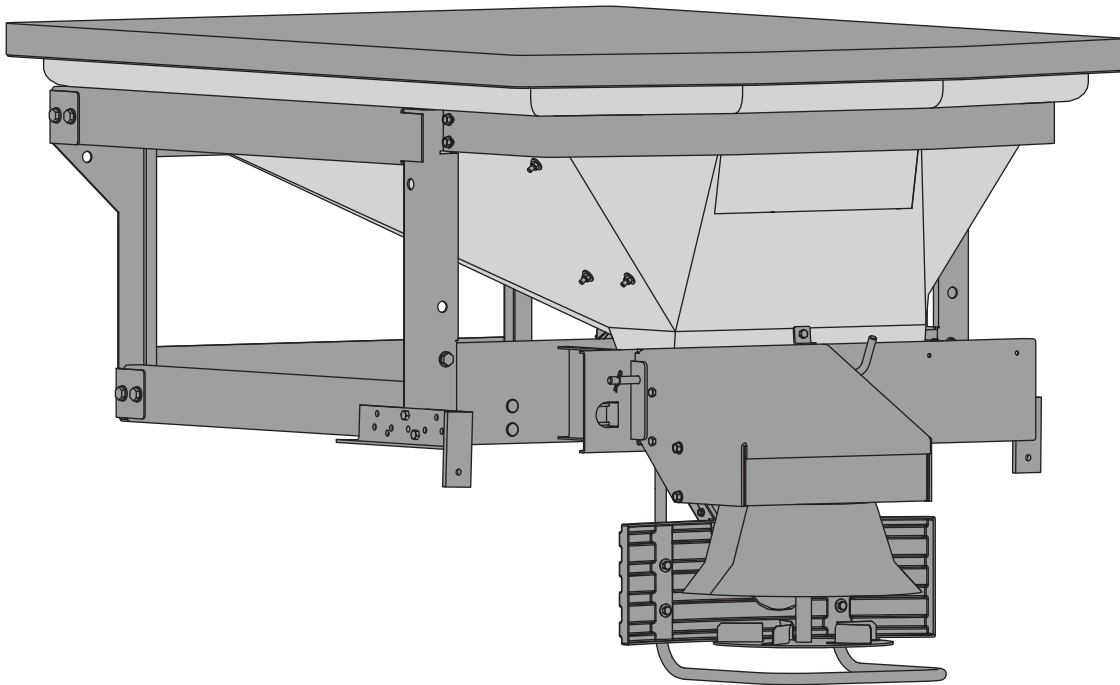

# Hopper Spreader Components

## POLY-CASTER™ LT Hopper Spreader

### Parts List



This Parts List is for FISHER® POLY-CASTER LT hopper spreaders with serial numbers 0000 and higher.

# POLY-CASTER™ LT HOPPER SPREADER

## FRAME ASSEMBLY

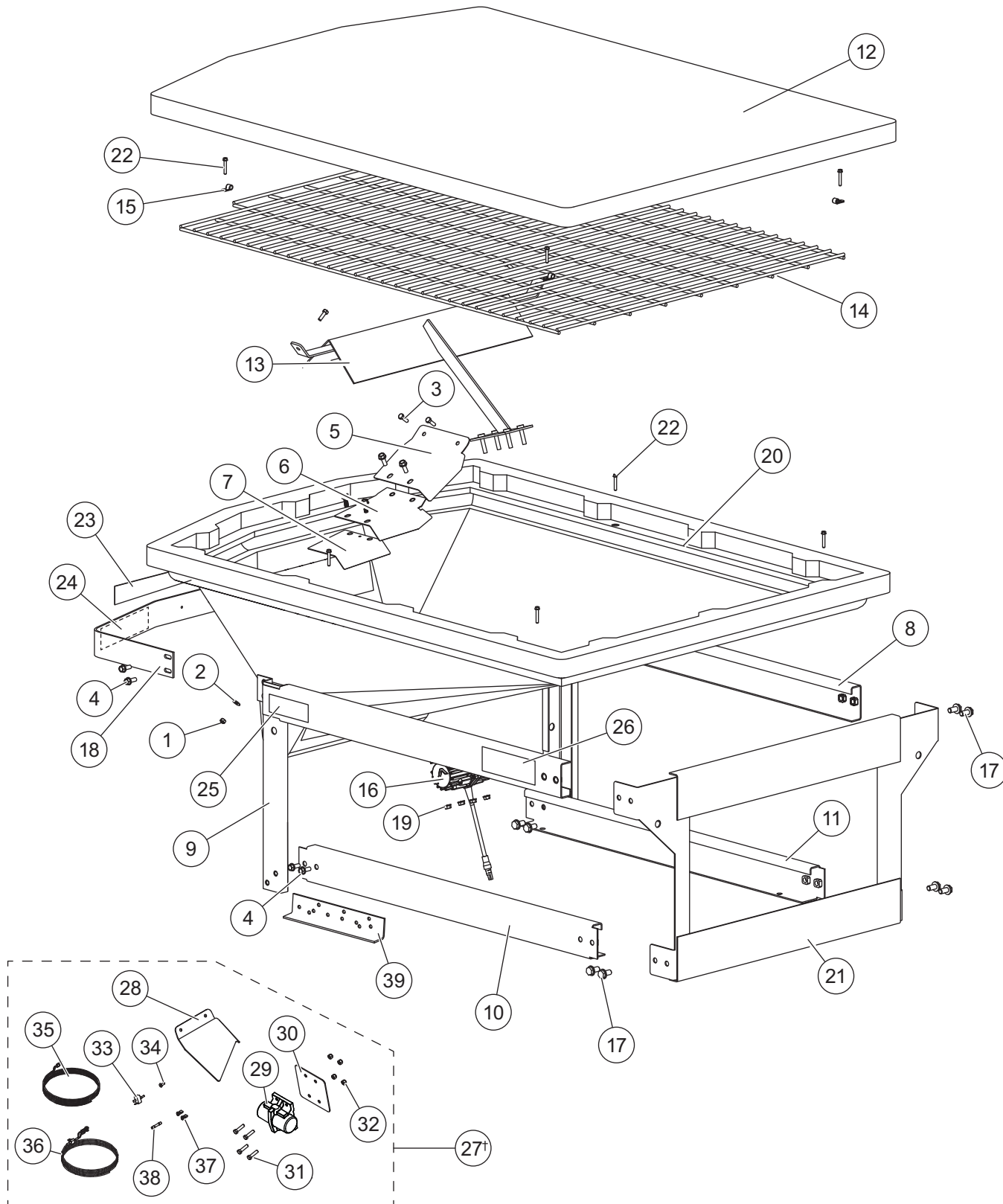

**POLY-CASTER™ LT HOPPER SPREADER**

Frame Assembly							
Item	Part	Qty	Description	Item	Part	Qty	Description
1	91332	4	5/16-18 Hex Locknut GB	15	51066	4	5/16 Clamp
2	90313	4	5/16 Flat Washer	16	51068	1	Vibrator 0.5 yd Hopper
3	68494	4	5/16-18 x 1 Hex Cap Screw	17	51074	8	1/2-13 x 1 Hex Cap Screw Serrated
4	51049	12	3/8-16 x 1 Serrated Flange Type F	18	51075	1	Hopper Apron
5	51052	1	Main Baffle	19	51092	4	3/8-16 Serrated Flange Nut
6	51053	1	Secondary Baffle	20	51095	1	Hopper, POLY-CASTER LT, Yellow
7	51054	1	Third Baffle	21	51099	1	Front Frame
8	51055	1	Frame Right	22	51103	8	1/4 x 1-1/2 Driller w/Washer
9	51056	1	Frame Left	23	51104	1	Conspicuity Tape
10	51057	1	Lower Rail Right	24	42721	1	Label, POLY-CASTER LT Logo
11	51058	1	Lower Rail Left	25	D6546	1	Label, Warning GVWR
12	51062	1	Tarp Kit	26	69808	2	Label, FISHER® Logo
13	51064	1	Inverted V 0.5 yd Hopper	27†	51106	1	Optimum Flow Kit
14	51065	1	Top Screen 0.5 yd Hopper	ns	51019	1	Spreader Mounting Kit
<b>Item 27† 51106 Optimum Flow Kit</b>							
28	88295	1	Opti-Flow Baffle	34	88291	1	Rubber Switch Boot
29	88283	1	DC-80 Vibrator	35	88289	1	Spreader/Vehicle Harness 20'
30	88284	1	Vibrator Backing Plate	36	88290	1	Battery Harness 10'
31	90043	4	3/8-16 x 2 Hex Cap Screw G5	37	88294	2	Spade Connector
32	91333	4	3/8-16 Hex Locknut GB	38	88287	1	Butt Connector
33	88285	1	ON/OFF Switch	ns	88288	1	Dielectric Grease
<b>51019 Spreader Mounting Kit</b>							
39	51078	1	Adjustable Stop Bracket, Right	ns	90572	4	1/2 Flat Washer, Hardened
ns	51079	1	Adjustable Stop Bracket, Left	ns	91335	4	1/2-13 Hex Locknut GB
ns	51063	1	Ratchet Strap (pkg of 4)	ns	90039	4	3/8-16 x 1 Hex Cap Screw G5
ns	90210	4	1/2-13 x 1-1/2 Hex Cap Screw G5	ns	91333	4	3/8-16 Hex Locknut GB
ns = not shown		† = Accessory Only			G = Grade		

# POLY-CASTER™ LT HOPPER SPREADER

## AUGER ASSEMBLY

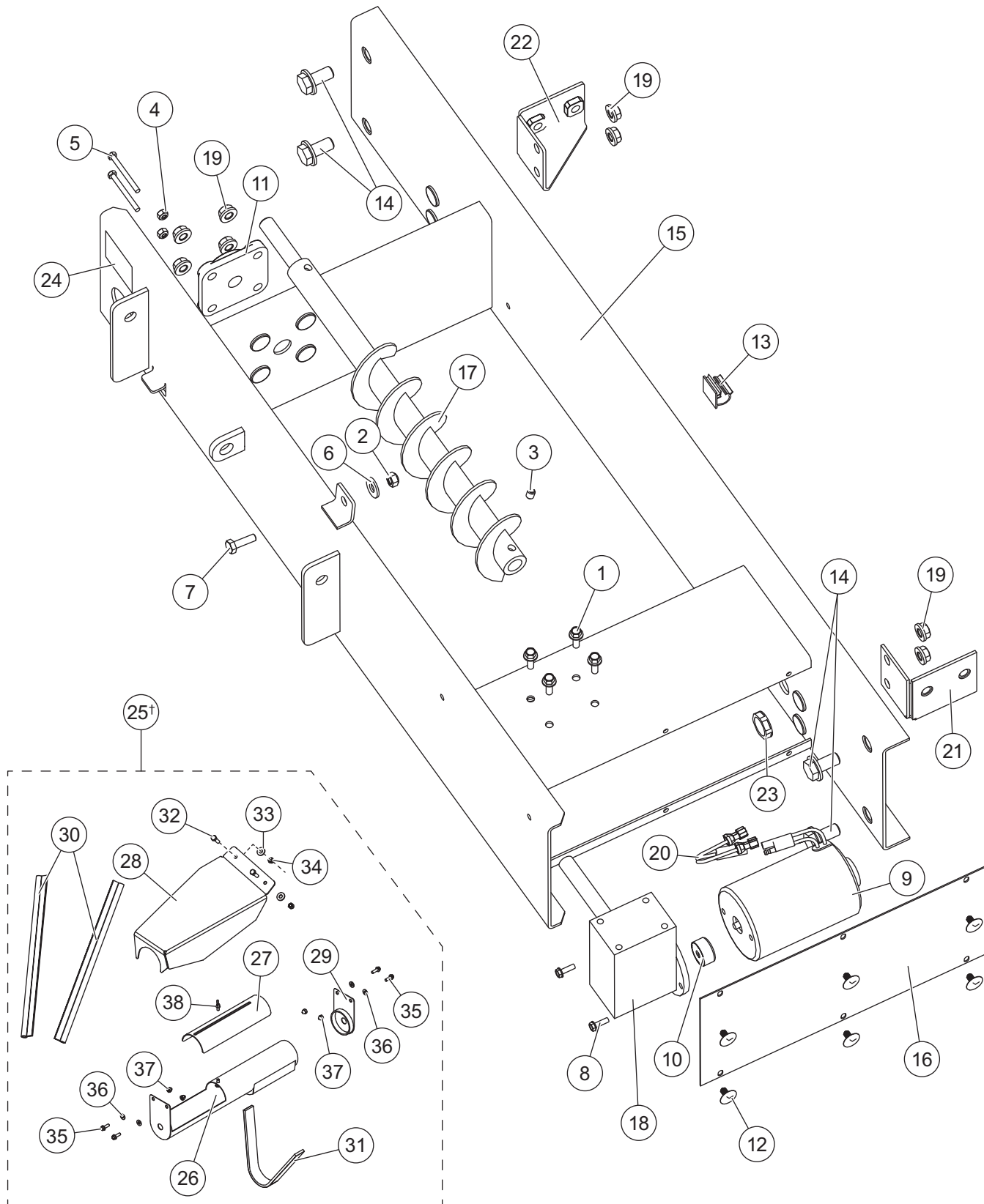

**POLY-CASTER™ LT HOPPER SPREADER**

Auger Assembly							
Item	Part	Qty	Description	Item	Part	Qty	Description
1	51031	4	1/4-20 x 3/4 Serrated Flange SS	14	51074	4	1/2-13 x 1 Hex Cap Screw Serrated
2	91332	1	5/16-18 Hex Locknut GB	15	51076	1	Auger Drive Weldment
3	51034	1	5/16-18 x 3/8 Set Screw	16	51077	1	Auger Motor Cover
4	88266	2	#10-32 Hex Locknut	17	51087	1	Auger
5	51035	2	#10-32 x 2 Hex Cap Screw SS	18	51090	1	Transmission 30:1
6	90313	1	5/16 Flat Washer	19	51092	8	3/8-16 Flange Nut, Serrated
7	68494	1	5/16-18 x 1 Hex Cap Screw	20	51096	1	Spinner Motor Connector
8	51039	2	#10-32 x 5/8 Serrated Flange w/Patch	21	88269	1	Lower Rail Mount Bracket Right
9	51040	1	3" 12 V DC Motor w/2-Pin Connector	22	51098	1	Lower Rail Mount Bracket Left
10	51041	1	Motor Drive Coupler	23	51101	1	1/2" NPT Nut Black Nylon
11	51043	1	5/8 Bearing 4 Bolt Flange	24	D6548	1	Label, Warning – Read Manual
12	51050	6	1/4 x 3/4 x 1/2 Push Retainer	25†	51107	1	Auger Tube Restrictor Kit
13	51051	1	3/8 Wire Clamp				
<b>Item 25†</b>				<b>51107 Auger Tube Restrictor Kit</b>			
26	88275	1	Auger Tube	33	90313	2	5/16 Flat Washer
27	88277	1	Gate Slide, Auger Tube	34	91332	2	5/16-18 Hex Locknut GB
28	88278	1	Material Baffle TRK-3000	35	51031	4	1/4-20 x 3/4 Hex Cap Screw, Serrated Flange SS
29	88276	1	End Cap, Auger Tube	36	50969	4	1/4 Flat Washer SS
30	88281	1	Edge Grip Seal – 36"	37	50970	4	1/4-20 Hex Locknut Waxed SS
31	88282	1	1-1/4" Adhesive-Back Foam – 18"	38	88274	1	1/4-20 Wing Nut SS
32	68494	2	5/16-18 x 1 Hex Cap Screw G5				
SS = Stainless Steel		† = Accessory Only		G = Grade			

# POLY-CASTER™ LT HOPPER SPREADER

## DRIVE ASSEMBLY

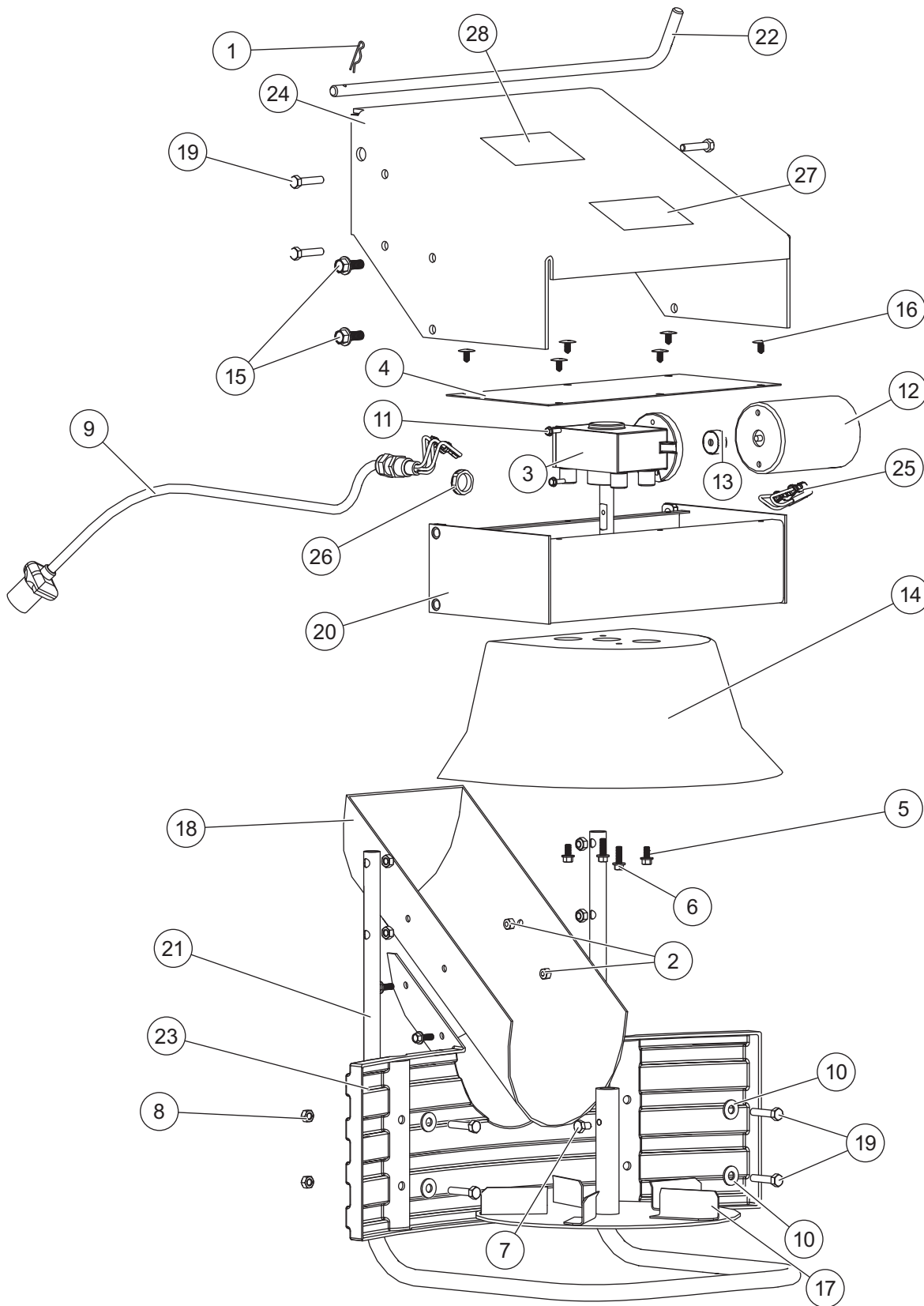

**POLY-CASTER™ LT HOPPER SPREADER**

Drive Assembly							
Item	Part	Qty	Description	Item	Part	Qty	Description
1	51024	1	0.093 x 2-3/8 Hairpin Cotter	15	51049	4	3/8-16 x 1 Serrated Flange Type F
2	91331	4	1/4-20 Hex Locknut GB	16	51050	6	1/4 x 3/4 x 1/2 Push Retainer
3	51028	1	Transmission 8:1	17	51069	1	Spinner w/Extended Shaft 12"
4	51029	1	Spinner Drive Enclosure	18	51070	1	Material Chute
5	51030	2	1/4-20 x 1/2 Serrated Flange SS	19	51072	8	5/16-18 x 1-1/2 Tapping Screw
6	51031	6	1/4-20 x 3/4 Serrated Flange SS	20	51080	1	Spinner Drive Enclosure
7	51032	1	5/16-18 x 1/2 Hex Cap Screw G5	21	51081	1	Tubular Spinner Guard
8	91332	8	5/16-18 Hex Locknut GB	22	51088	1	Bent Pin
9	51036	1	Power Cable	23	51089	1	Spinner Deflector
10	90313	4	5/16 Flat Washer	24	51091	1	Drive Enclosure Shroud
11	51039	2	#10-32 x 5/8 Serrated Flange w/Patch	25	51097	1	Auger Motor Connector
12	51040	1	3" 12 V DC Motor w/2-Pin	26	51101	1	1/2" NPT Nut Black Nylon
13	51041	1	Motor Drive Coupler	27	D6544	1	Label, Warning Rotating Parts
14	51045	1	CE Shroud	28	D6545	1	Label, Warning No Step
ns = not shown			SS = Stainless Steel			G = Grade	

# POLY-CASTER™ LT HOPPER SPREADER

## ELECTRICAL COMPONENTS

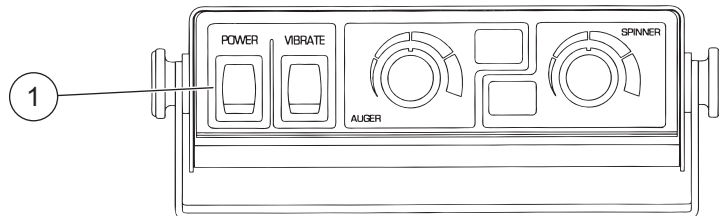

### Spreader Harness

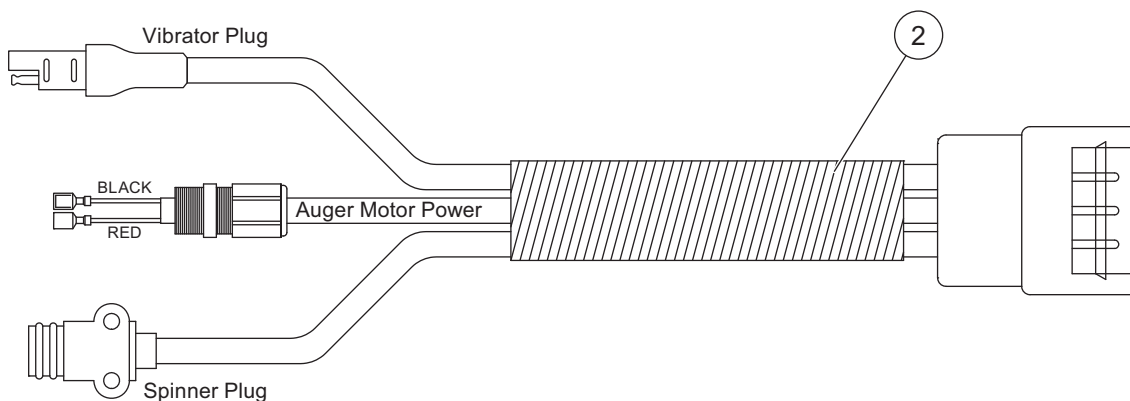

### Vehicle Harness

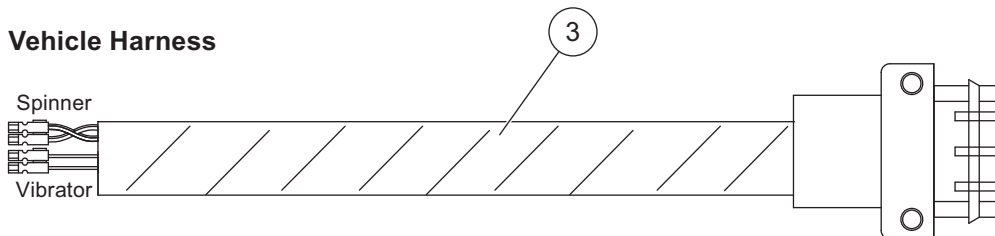

### Control Power Cable

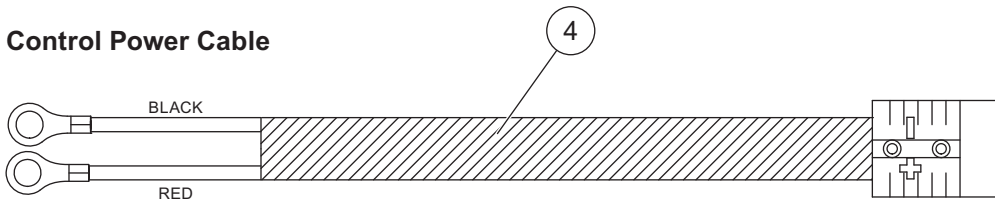



**POLY-CASTER™ LT HOPPER SPREADER**

---

Electrical Components							
Item	Part	Qty	Description	Item	Part	Qty	Description
1	51073	1	Spreader Control	3	51086	1	Vehicle Harness
2	51067	1	Spreader Harness	4	51105	1	Control Power Cable

**www.storksplows.com**  
**POLY-CASTER™ LT HOPPER SPREADER**

---

Copyright © 2013 Douglas Dynamics, LLC. All rights reserved. This material may not be reproduced or copied, in whole or in part, in any printed, mechanical, electronic, film or other distribution and storage media, without the written consent of Fisher Engineering. Authorization to photocopy items for internal or personal use by Fisher Engineering outlets or spreader owner is granted.

Fisher Engineering reserves the right under its product improvement policy to change construction or design details and furnish equipment when so altered without reference to illustrations or specifications used. Fisher Engineering or the vehicle manufacturer may require or recommend optional equipment for spreaders. Do not exceed vehicle ratings with a spreader. Fisher Engineering offers a limited warranty for all spreaders and accessories. See separately printed page for this important information. The following are registered (®) or unregistered (™) trademarks of Douglas Dynamics, LLC: FISHER®, POLY-CASTER™ LT.

**Printed in U.S.A.**

---