

35066

MOUNT KIT

Nissan Titan

2004 - 09

Installation Instructions

⚠ CAUTION

Read this document before installing the snowplow.

⚠ CAUTION

See your sales outlet/Web site for specific vehicle application recommendations before installation. The Selection List/Undercarriage Selection Guide has specific vehicle and snowplow requirements.

SAFETY DEFINITIONS

⚠ WARNING
Indicates a potentially hazardous situation that, if not avoided, could result in death or serious personal injury.

⚠ CAUTION
Indicates a potentially hazardous situation that, if not avoided, may result in minor or moderate injury. It may also be used to alert against unsafe practices.

NOTE: Indicates a situation or action that can lead to damage to your snowplow and vehicle or other property. Other useful information can also be described.

WARNING/CAUTION & INSTRUCTION LABELS

Become familiar with and inform users about the warning and instruction labels on the back of the blade.

NOTE: If labels are missing or cannot be read, see your sales outlet.

Warning and Caution Label

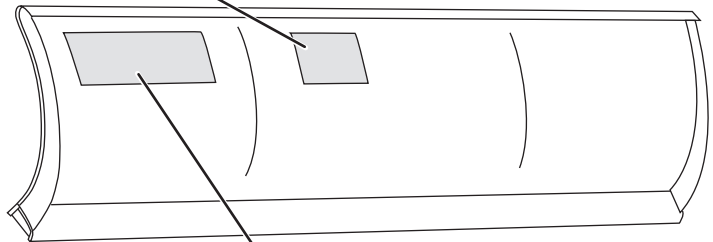
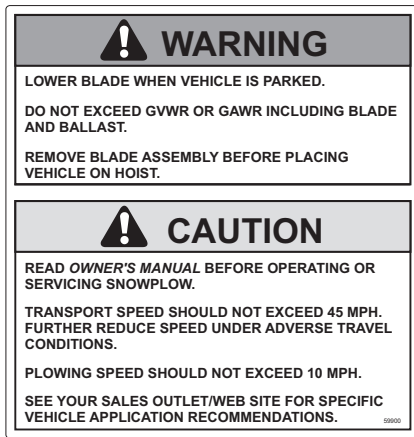

Attach/Detach Instruction Label

SAFETY PRECAUTIONS

Improper installation and operation could cause personal injury and/or equipment and property damage. Read and understand labels and the Owner's Manual before installing, operating or making adjustments.

⚠ WARNING

Lower blade when vehicle is parked. Temperature changes could change hydraulic pressure, causing the blade to drop unexpectedly or damaging hydraulic components. Failure to do this could result in serious personal injury.

⚠ WARNING

The driver shall keep bystanders clear of the blade when it is being raised, lowered or angled. Do not stand between the vehicle and the blade or within 8 feet of a moving blade. A moving or falling blade could cause personal injury.

⚠ WARNING

Keep hands and feet clear of the blade and A-frame when mounting or removing the snowplow. Moving or falling assemblies could cause personal injury.

⚠ WARNING

Do not exceed GVWR or GAWR including the blade and ballast. The rating label is found on the driver-side vehicle door cornerpost.

⚠ WARNING

To prevent accidental movement of the blade, always turn the control OFF whenever the snowplow is not in use. The power indicator light will turn OFF.

⚠ WARNING

Remove blade assembly before placing vehicle on hoist.

⚠ CAUTION

Refer to the Undercarriage Selection Guide/Selection List for minimum vehicle recommendations and ballast requirements.

PERSONAL SAFETY

- Remove ignition key and put the vehicle in park or in gear to prevent others from starting the vehicle during installation or service.
- Wear only snug-fitting clothing while working on your vehicle or snowplow.
- Do not wear jewelry or a necktie, and secure long hair.
- Wear safety goggles to protect your eyes from battery acid, gasoline, dirt and dust.
- Avoid touching hot surfaces such as the engine, radiator, hoses and exhaust pipes.
- Always have a fire extinguisher rated BC handy, for flammable liquids and electrical fires.

FIRE AND EXPLOSION

⚠ WARNING

Gasoline is highly flammable and gasoline vapor is explosive. Never smoke while working on vehicle. Keep all open flames away from gasoline tank and lines. Wipe up any spilled gasoline immediately.

Be careful when using gasoline. Do not use gasoline to clean parts. Store only in approved containers away from sources of heat or flame.

CELL PHONES

A driver's first responsibility is the safe operation of the vehicle. The most important thing you can do to prevent a crash is to avoid distractions and pay attention to the road. Wait until it is safe to operate Mobile Communication Equipment such as cell phones or two-way radios.

VENTILATION



⚠ WARNING

Vehicle exhaust contains lethal fumes. Breathing these fumes, even in low concentrations, can cause death. Never operate a vehicle in an enclosed area without venting exhaust to the outside.

TORQUE CHART

⚠ CAUTION

Read instructions before assembling. Fasteners should be finger tight until instructed to tighten according to the torque chart. Use standard methods and practices when attaching snowplow including proper personal protective safety equipment.

Recommended Fastener Torque Chart (ft-lb)			
Size	Torque		
	 SAE Grade 2	 SAE Grade 5	 SAE Grade 8
1/4-20	6	9	13
5/16-18	11	18	28
3/8-16	19	31	46
3/8-24	24	46	68
7/16-14	30	50	75
1/2-13	45	75	115
9/16-12	66	110	165
5/8-11	93	150	225
3/4-10	150	250	370
7/8-9	150	378	591
1-8	220	583	893
Metric Grade 8.8 (ft-lb)			
Size	Torque	Size	Torque
M 6	7	M 12	60
M 8	17	M 14	95
M 10	35	M 16	155
These torque values apply to fasteners except those noted in the instruction.			

MOUNT INSTALLATION

NOTE: For easier assembly and installation, vehicle and all snowplow components should be on a smooth, level, hard surface, such as concrete.

1. **If the vehicle is equipped with a stamped-steel splash guard and/or tow hooks**, remove them. Retain the splash guard, tow hooks and fasteners for reinstallation if the snowplow mount is removed.

If the vehicle is equipped with a front skid plate, remove it and the adjoining support brackets and tow hooks. Retain the skid plate, support brackets, tow hooks and fasteners for reinstallation if the snowplow mount is removed. Remove the license plate and connecting bracket assembly from the skid plate and reinstall it to the vehicle's front bumper as located by the preexisting detents.

2. Position the driver-side mount against the bottom surfaces of the vehicle frame rail while aligning the front mount hole with the tow hook hole. Secure the mount to the frame rail with M12 x 40 mm cap screws and 1/2" flat washers (supplied with the mount). Hand tighten only.
3. Clamp the rear of the mount against the bottom surface of the vehicle frame rail.

⚠ CAUTION

Use caution not to pinch, cut or drill through any wires or hoses running along the frame rail.

4. Remove the bumper brace to gain access for drilling holes through the vehicle frame rails. Using the rear hole in the mount as a guide, drill a 17/32" hole through the outside wall of the vehicle frame rail.
5. Place a 1/2" flat washer onto a 1/2" cap screw with handle and insert the fastener into the slot located on the bottom surface of the vehicle frame rail rearward of the mount. Pass the fastener out through the vehicle frame and mount hole, bending the handle as necessary. Place a 1/2" locknut on the fastener, and hand tighten.



6. Repeat Steps 2–5 on the opposite side of the vehicle.
7. Install the rubber splash shield as instructed below before installing the cross bar to the mount.

SPLASH SHIELD INSTALLATION

- Lay the rubber material on a flat surface. Drill four holes in the trimmed rubber splash shield according to the layout illustrated below.

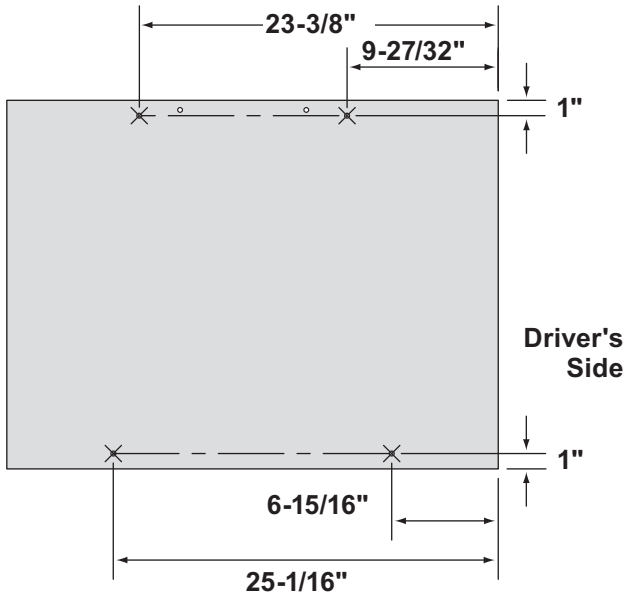

✕ = Measure and drill 5/16" holes (4 places).

○ = Use vehicle frame as guide to drill 5/16" holes (2 places).

- Cut the material as shown below.

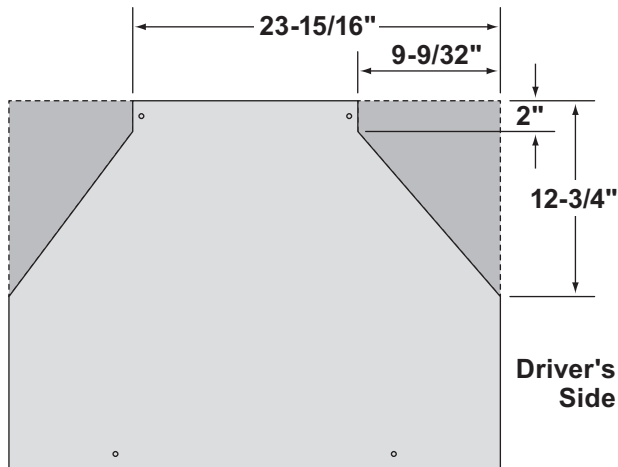

- Position the splash shield on the vehicle so that the tapered end is toward the rear and the shield is on top of the mount and below the vehicle sway bar.

FINISH SPLASH SHIELD AND MOUNT INSTALLATION

- If the vehicle is equipped with a transaxle skid plate, remove the two front skid plate bolts. Position the tapered end of the splash shield between the skid plate and the vehicle frame cross member. Install two M6 x 25 mm cap screws (supplied with the mount) through the holes drilled in Step 1 and into the cross member. Do not overtighten. Using the holes in the skid plate as guides, drill two 5/16" holes in the rubber splash shield. Reinstall the two skid plate bolts through the skid plate and splash shield.



If the vehicle is not equipped with a transaxle skid plate, align the holes in the rear splash shield retainer and the tapered end of the splash shield with those in the vehicle frame cross member. Install two M6 x 25 mm cap screws (supplied with the mount) through the rear splash shield retainer and splash shield and into the cross member. Do not overtighten.



12. Make sure the splash shield is under the vehicle sway bar, then pull the uncut end of the shield to the vehicle bumper support beam.
13. Attach the front of the splash shield to the angled surface of the vehicle bumper support beam using the front splash shield retainer and the M6 x 25 mm cap screws (supplied with the mount).
14. Install the cross bar using four 1/2" x 1-1/2" cap screws and 1/2" locknuts. Hand tighten fasteners.
15. Make sure that the mounts are tight against the truck frame. Then fully tighten the fasteners securing the mounts, followed by the fasteners securing the cross bar, according to the torque chart.
16. Check for a U-bracket distance of $30\text{-}7/16" \pm 1/8"$. Take a second measurement farther back on the mounts to ensure that they are parallel. If the U-bracket distance is not within the $30\text{-}7/16" \pm 1/8"$, then 1/2" flat washers may be used to shim one or both mounts in the appropriate direction to obtain the desired dimension.
17. Tighten all fasteners according to the torque chart after achieving the appropriate dimension.
18. Bend or cut the ends of the cap screw handles protruding out from the truck frame.
19. Reinstall the bumper braces on both sides of the vehicle.

NOTE: After five to ten hours of snowplow usage, retorque all mount assembly fasteners.

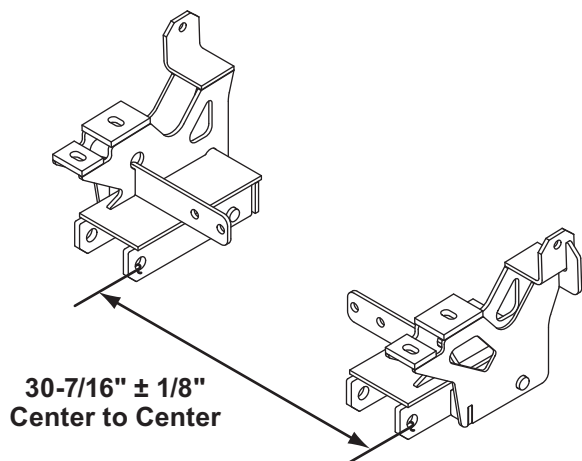

The company reserves the right under its product improvement policy to change construction or design details and furnish equipment when so altered without reference to illustrations or specifications used. This equipment manufacturer or the vehicle manufacturer may require or recommend optional equipment for snow removal. Do not exceed vehicle ratings with a snowplow. The company offers a limited warranty for all snowplows and accessories. See separately printed page for this important information.

Printed in U.S.A.
