

www.storksplovs.com
**MUX STRAIGHT BLADE W/SCRAPE LOCK
 HYDRAULIC UNIT SERVICE INSTRUCTIONS**

Relief Valve Service: Apply one drop of low-strength threadlocker to all relief valve stems. The spring for relief valve D is different from the other springs and should not be interchanged.

Relief Valve A and B Adjustment: Screw stem in until spring is fully compressed, then back out 1 to 1-1/4 turns for approximately 4000 psi angle ram relief.

⚠ WARNING
 Do not stand between the vehicle and the blade or within 8 feet of a moving blade. A moving or falling blade could cause personal injury.

Relief Valve C Adjustment: Attach 3000 psi gauge in line with PS ram. Adjust relief valve C to obtain 1650 psi pump relief pressure at full angle left. Relieve pressure before adjusting.

Relief Valve D Adjustment: Attach 3000 psi gauge in line with base end of lift ram. Adjust relief valve D to obtain 350 psi while blade is being raised. Relieve pressure before

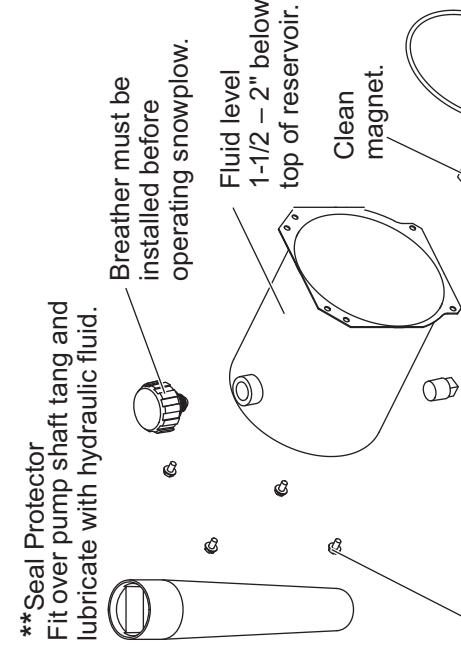

10-24 x 5/16 Washer-Head Screw (4) - 30-35 in-lb
 Apply low-strength threadlocker

Replace O-ring whenever disassembled. Apply light film of white lithium grease for reassembly. Clean manifold groove and reservoir surface.

5/16-18 x 2-1/4 Cap Screw (5)
 150-160 in-lb

Snap filter onto tube and align filter as shown in end view.†

Remove motor. Fit seal protector onto end of pump shaft and install lubricated shaft through seal.**

General

1. Before any service, loosen breather to relieve reservoir pressure.
2. Lubricate all O-rings with clean hydraulic fluid except where noted otherwise.
3. DS = Driver's Side
 PS = Passenger's Side

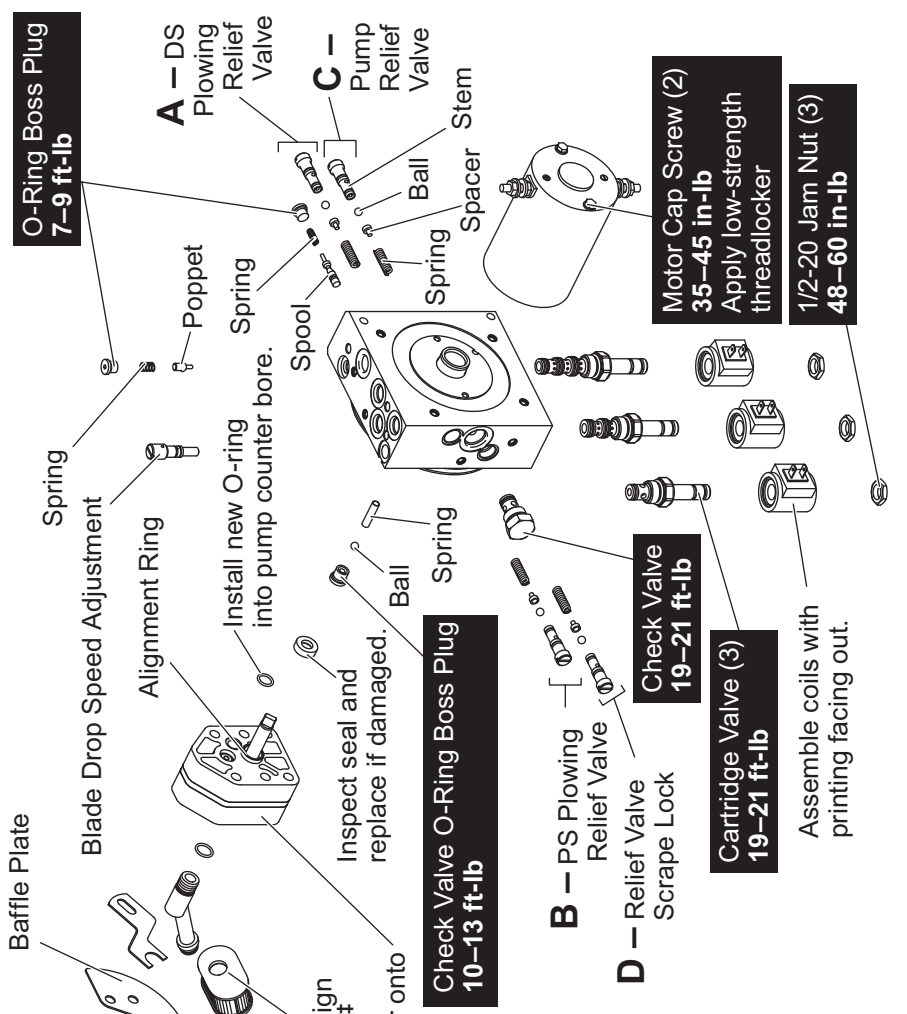
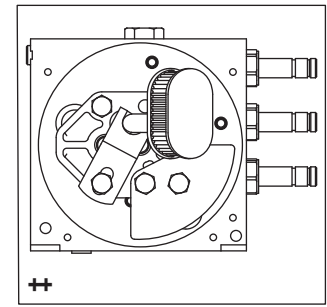

www.storksplovs.com
**MUX STRAIGHT BLADE W/SCRAPE LOCK
 HYDRAULIC UNIT SERVICE INSTRUCTIONS**

ELECTRICAL ASSEMBLY

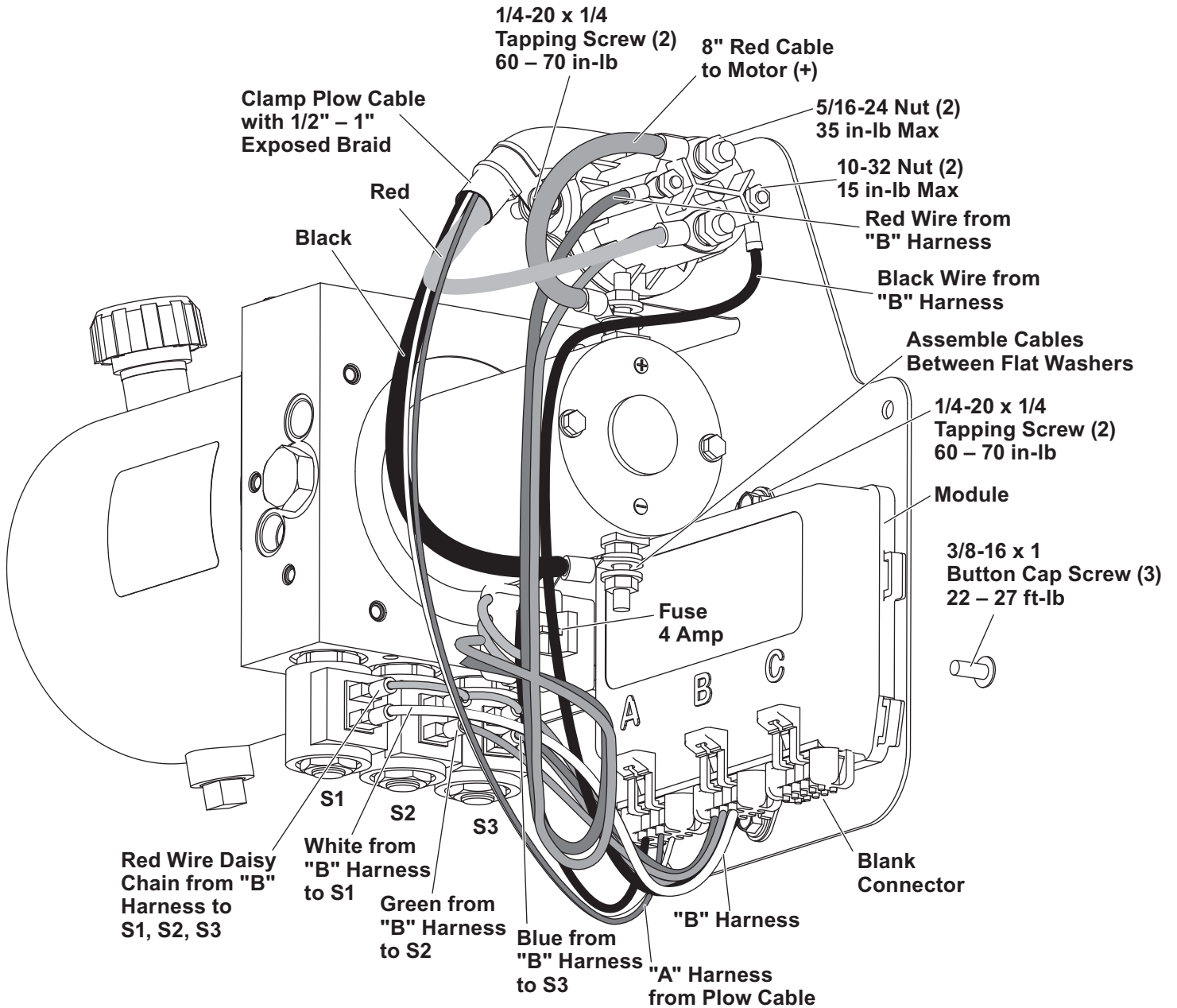

www.storksplovs.com
**MUX STRAIGHT BLADE W/SCRAPE LOCK
 HYDRAULIC UNIT SERVICE INSTRUCTIONS**

TORQUE CHART

MUX Straight Blade w/Scrape Lock Hydraulic Unit Torque Chart		
Location	Fastener Size	Torque
Pump Cap Screws	5/16-18 x 2-1/4	150–160 in-lb
Motor Terminals (+ and –)	M6 Nut	25–35 in-lb
Motor to Manifold Cap Screws	M5 x .8	35–45 in-lb*
Reservoir Screws	#10-24 x 5/16	30–35 in-lb*
Solenoid Valves	7/8 Hex Head	19–21 ft-lb
Coil Nuts	3/4 Hex Head Jam Nut	48–60 in-lb
SAE O-Ring Plugs	1/8 or 5/32 Internal Hex	55–65 in-lb
Hydraulic Unit Mount Bolts	3/8-16 x 1	22–25 ft-lb
Check Valves	7/8 Hex Head	19–21 ft-lb
Motor Relay Small Terminals	10-32 Nut	15 in-lb max
Motor Relay Large Terminals	5/16-24 Nut	35 in-lb max
Motor Relay Mount Screws	1/4-20 x 5/8	75–85 in-lb
Plow Module Mount Screws	1/4-20 x 5/8	60–70 in-lb

* Torque with low-strength thread locker

HYDRAULIC FLUID (DRAIN AND FILL), FITTINGS AND HOSES

NOTE: Before removing hoses and fittings, carefully note hose routing for proper reassembly. For complete hydraulic fluid level/change or hose/fitting instructions, see the Maintenance Section of your Owner's Manual.

Align fittings to route hoses out through the hole in the mounting plate.

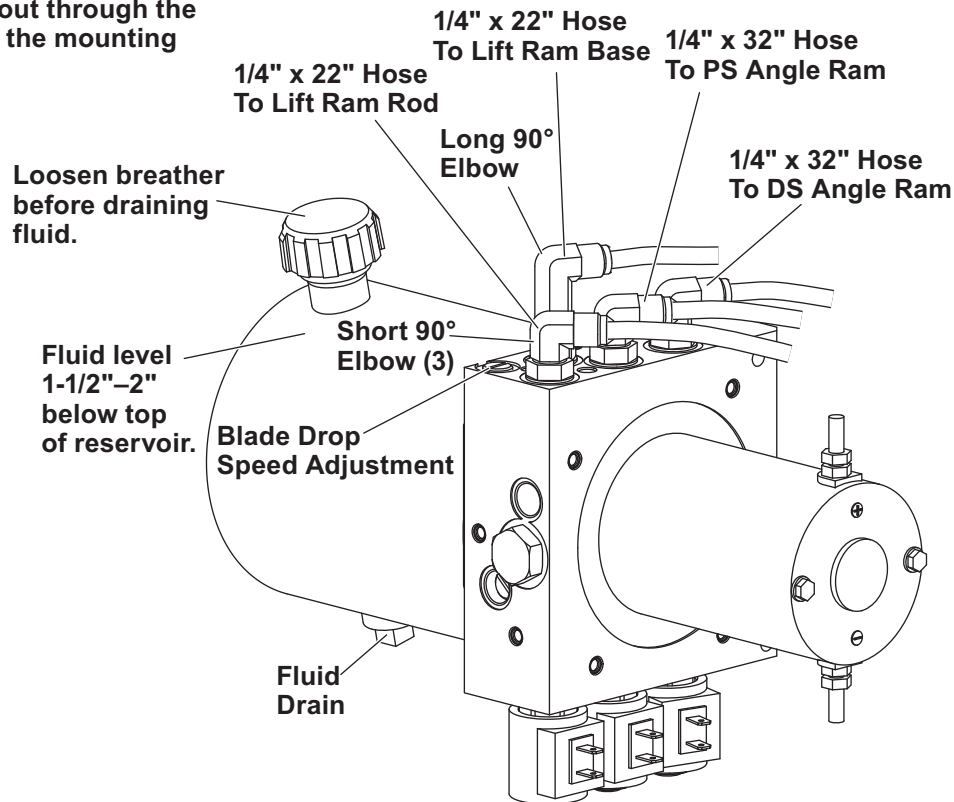

www.storksplovs.com
**MUX STRAIGHT BLADE W/SCRAPE LOCK
HYDRAULIC UNIT SERVICE INSTRUCTIONS**

The company reserves the right under its product improvement policy to change construction or design details and furnish equipment when so altered without reference to illustrations or specifications used. This equipment manufacturer or the vehicle manufacturer may require or recommend optional equipment for snow removal. Do not exceed vehicle ratings with a snowplow. The company offers a limited warranty for all snowplows and accessories. See separately printed page for this important information.

Printed in U.S.A.
