



Fisher Engineering

50 Gordon Drive, Rockland, Maine 04841-2139 • www.fisherplows.com

27517-1

27550

August 15, 2009
Lit. No. 48591, Rev. 00



Homesteader™ Personal Plow

Plow Gear Kit and Hydraulic Kit

Parts List

Homesteader™ OFF-TRUCK KITS 4

 Plow Gear and A-Frame 4

 Hydraulic Unit..... 6

 Lift and Angle Rams 8

 Hoses and Fittings..... 9

 Vehicle-Side Wiring Diagram – 3-Port, 3-Plug Systems..... 10

Plow Gear and A-Frame Components

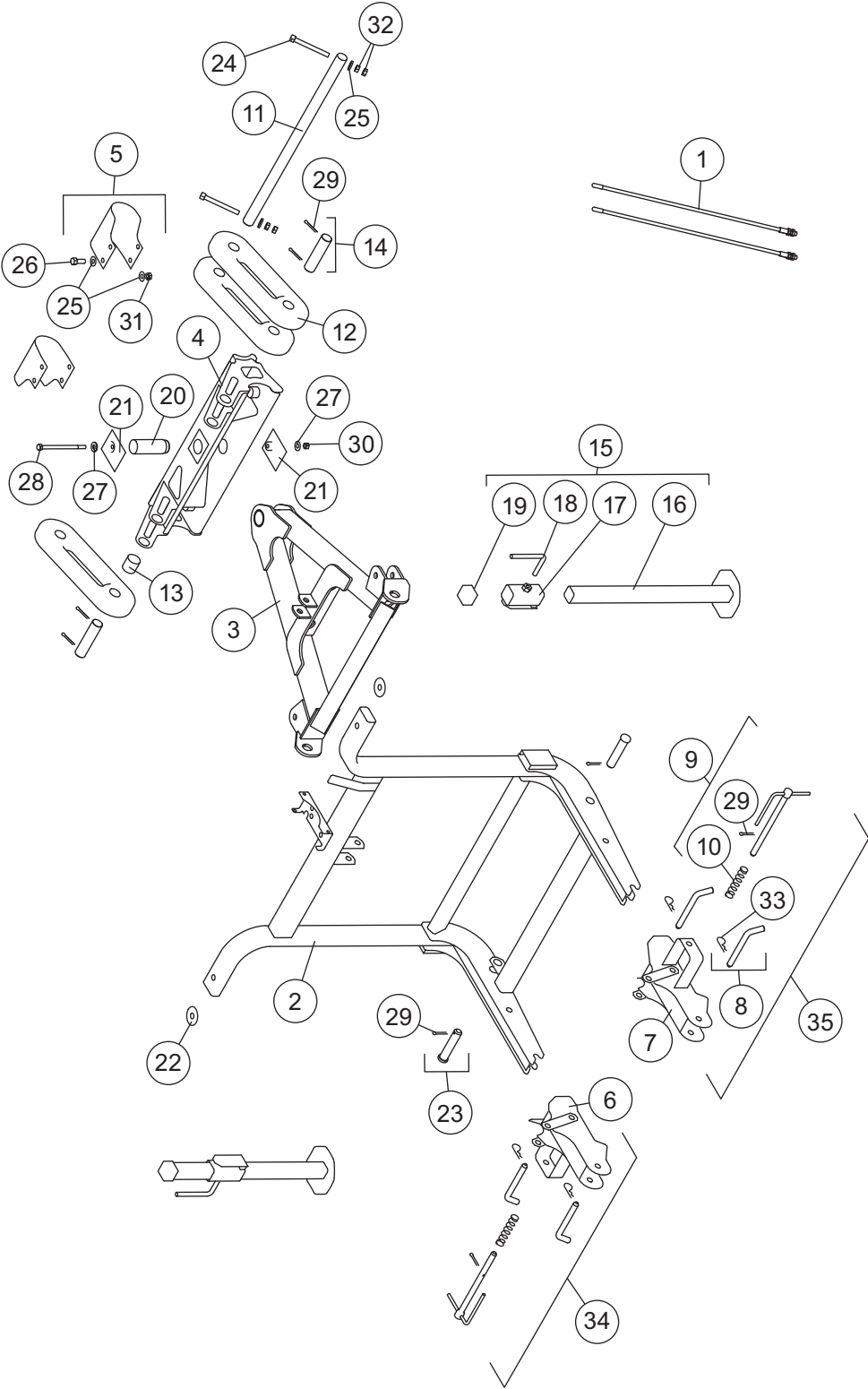

27550 Plow Gear Kit – Personal Plow							
Item	Part	Qty	Description	Item	Part	Qty	Description
1	27195	1	Flexible Blade Guide Kit – 26" (Pair)	18	27358	2	Jack Handle
2	27126	1	Plow Gear Frame, Personal Plow	19	27692	2	Square Vinyl Cap
3	27138	1	A-Frame, Personal Plow	20	27141	1	Pivot Tube
4	27112	1	Quadrant, Personal Plow	21	27615	2	Trip Bumper
5	27577	2	Trip Clamp Replacement Kit w/Fasteners	22	4433	2	1/2 Flat Washer
6	27146	1	Receiver – DS	23	20639	2	3/4 x 3-15/32 Machine Pin Packet
7	27611	1	Receiver – PS	24	27529	2	3/8-16 x 3-1/2 Hex Cap Screw G5
8	27575	4	Receiver Mounting Pin Kit	25	63925	18	3/8 Flat Washer
9	27576	2	Receiver Pull Pin Kit	26	90039	8	3/8-16 x 1 Hex Cap Screw G5
10	27461	2	Compression Spring	27	90313	2	5/16 Flat Washer
11	27149	1	Spring Bar Tube	28	90602	1	5/16-18 x 5 Hex Cap Screw G5
12	27351	3	Elastomeric Trip Spring	29	91911	8	5/32 x 1-1/2 Cotter Pin
13	27530	1	Trip Spring Spacer	30	91332	1	5/16-18 Hex Locknut GB
14	27711	2	Lower Trip Spring Pin Kit	31	91333	8	3/8-16 Hex Locknut GB
15	27360	2	Jack	32	91413	4	3/8-16 Hex Nut G5
16	27355	2	Jack Leg	33	91962	4	1/8 Hairpin Cotter
17	27357	2	Jack Sleeve	34	27754	1	Receiver Assembly – DS
				35	27755	1	Receiver Assembly – PS
27754 Receiver Assembly – DS							
6	27146	1	Receiver – DS			1	Receiver Pull Pin
		2	Receiver Mounting Pin	10	27461	1	Compression Spring
33	91962	2	1/8 Hairpin Cotter	29	90658	1	5/32 x 1-1/4 Cotter Pin
27755 Receiver Assembly – PS							
7	27611	1	Receiver – PS			1	Receiver Pull Pin
		2	Receiver Mounting Pin	10	27461	1	Compression Spring
33	91962	2	1/8 Hairpin Cotter	29	90658	1	5/32 x 1-1/4 Cotter Pin
G = Grade							

27517-1, 27550

Hydraulic Unit Components

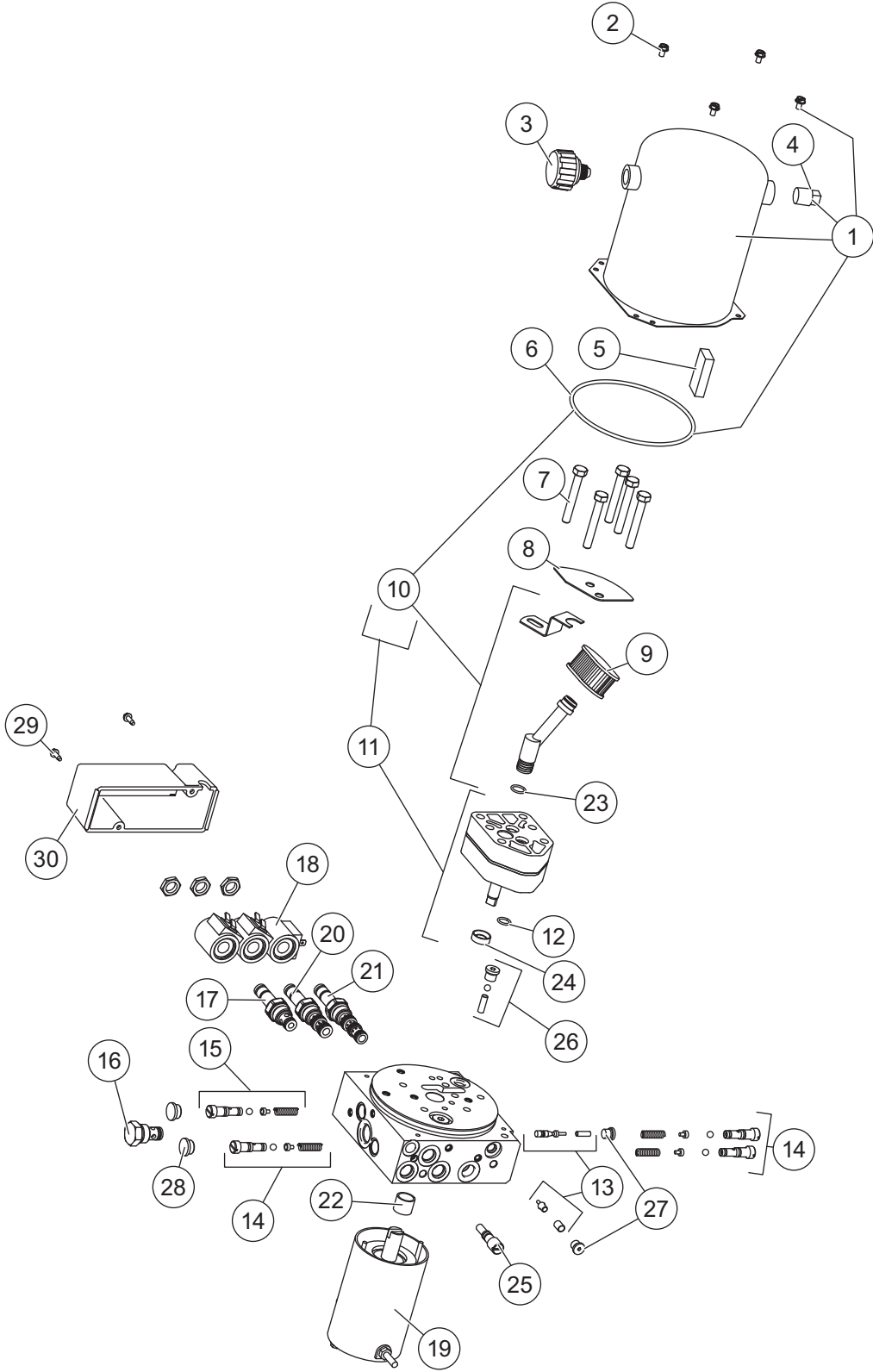

48601 Hydraulic Unit							
Item	Part	Qty	Description	Item	Part	Qty	Description
1	48538	1	Reservoir Kit	16	44333-1	1	Check Valve CV08-20
2	66607	4	10-24 x 5/16 Machine Screw Slotted Hex Washer Head	17	7634K-2	1	Valve 2-Way w/Nut
3	21727-2	1	Breather 3/8 NPT Kit	18	7639K-2	3	Coil w/Spade Terminals
4	92079	1	Plug 3/8 NPTF	19	27753	1	Motor Assembly 3"
5	73897	1	Magnet	20	66608K-1	1	Cartridge Valve 3-Way w/Nut
6	66519	1	O-Ring 2 – 250	21	7637K-1	1	Cartridge Valve 4-Way w/Nut
7	90073	5	5/16-18 x 2-1/4 Hex Cap Screw G5	22	64596	1	Bearing, Sleeve
8	48464	1	Plate Baffle	23	56416	1	O-Ring – 014
9	26781-3	1	Suction Filter	24	66515	1	Pump Shaft Seal
10	66763-1	1	Inlet Fitting/Filter Kit	25	48517	1	Quill
11	27746	1	Hydraulic Pump Kit – IA	26	48518	1	Check Valve Assembly
12	56274	1	O-Ring – 013	27	92960	2	3/8-24 O-Ring Boss Plug
13	7630K	1	Poppet Check Valve Kit	28	56808	2	Plug
14	7629K-3	2	Relief Valve Kit (2 Sets)	29	90650	2	Cover Screw
15	27792-1	1	Relief Valve Repair Kit	30	21394	1	Cover Assy
O-Ring Service Kits							
ns	7632K-3	–	O-Ring & Back-Up Ring Kit	ns	49259-2	–	Seal Kit Cartridge 3-Way and 4-Way Valve
ns	49258-2	–	Seal Kit 2-Way Valve				
ns = not shown				G = Grade			

48597 Personal Plow Hydraulic Bolt Bag*					
Part	Qty	Description	Part	Qty	Description
56725	7	O-Ring (male) to MJIC 90° Elbow	90010	2	1/4-20 x 2-3/4 Hex Cap Screw G5
44361	1	Elbow, Long 90° –6	8329K	1	Dielectric Grease Tube
27524	2	1/2-13 x 4 Hex Cap Screw G8	59223	4	Cable Tie
27525	3	1/2-13 x 3 Hex Cap Screw G8	61536	7	Long Cable Tie
27526	1	1/2-13 x 2-1/2 Hex Cap Screw G8	91331	2	1/4-20 Hex Locknut GB
91335	6	1/2-13 Hex Locknut GB			
8737 Small Bolt Bag*					
5048	1	1/4 Fully-Insulated Blade	91055	1	M6 x 1 x 25 Hex Cap Screw G8.8
21306	1	.187 Insulated Receptacle	91056	1	M6 x 1 Hex Nut G10
21307	1	.250 Insulated Receptacle	91057	1	M6 Flat Washer
21308	1	.250 Tab Fuse Tap	90311	2	1/4 Flat Washer
21309	1	.187 Tab Fuse Tap	91202	2	5/16 Spring Lock Washer
66130	1	Rubber Grommet	91242	2	10 Spring Lock Washer
91331	2	1/4-20 Hex Locknut GB	91402	2	10-32 Hex Machine Screw Nut
90461	2	1/4-20 x 3/4 Hex Cap Screw G5	92842	2	5/16-24 Hex Jam Nut G5
G = Grade			M = Male or Metric		

* found in 48596 Parts Box

27517-1, 27550

Angle Ram Components

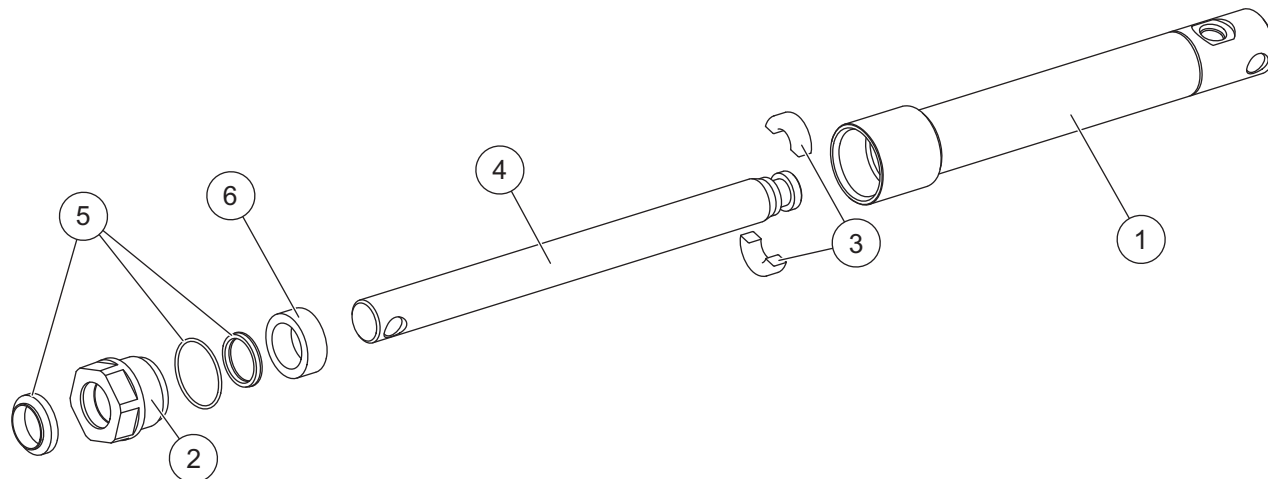

56772K 1 x 7 Ram Assembly							
Item	Part	Qty	Description	Item	Part	Qty	Description
1	56769	1	1 x 7 Cylinder	4	27786	1	1 x 7 Ram Rod Kit
2	66699K	1	Gland Nut	5	27787	1	1 Bore Ram Seal Kit
3	56771	1	1" Split Bearing Kit	6	56803	1	Spacer

Lift Ram Components

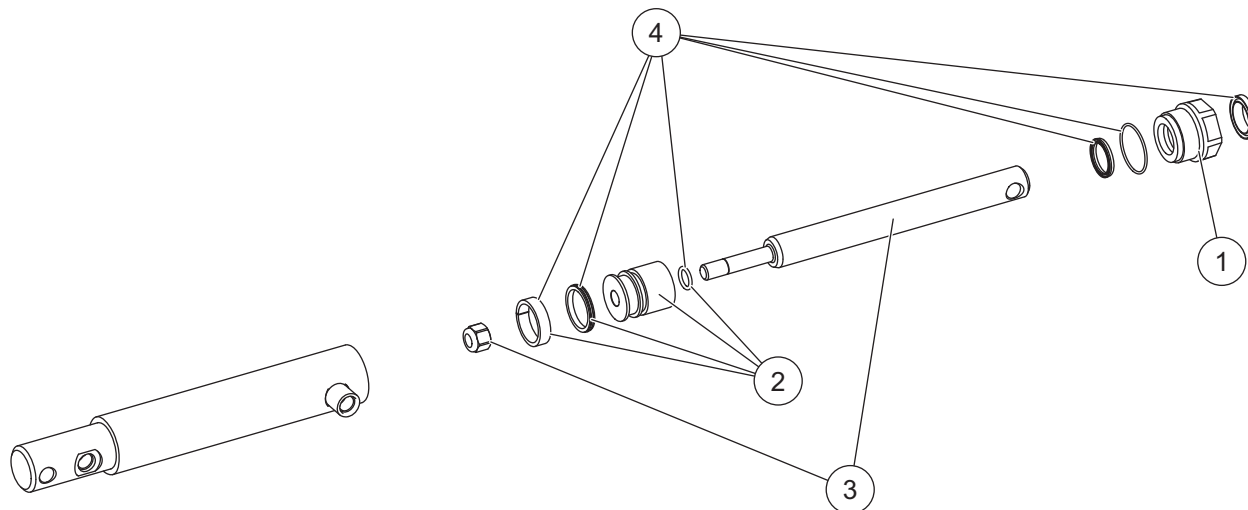

48600 1-1/2 x 6 Double-Acting Ram Assembly			
Item	Part	Qty	Description
1	66699K	1	Gland Nut
2	48606	1	1-1/2 Piston w/Seals
3	27790	1	1-1/2 x 6 Double-Acting Rod Assy
4	27788-1	1	1-1/2 Bore Double-Acting Ram Seal Kit
ns = not shown			

Parts Box Parts List

48596 Parts Box					
Part	Qty	Description	Part	Qty	Description
56598	1	1/4 x 22 Hose (FJIC Ends)	8284K	1	Cable Boot
56599	2	1/4 x 36 Hose (FJIC Ends)	8737	1	Small Bolt Bag
44311	1	1/4 x 12 Hose (FJIC Ends)	48597	1	Personal Plow Hydraulic Bolt Bag
22511	1	Battery Cable 22" Red	21727-2	1	Breather
5794K-1	1	Relay Switch			

Hoses and Fittings

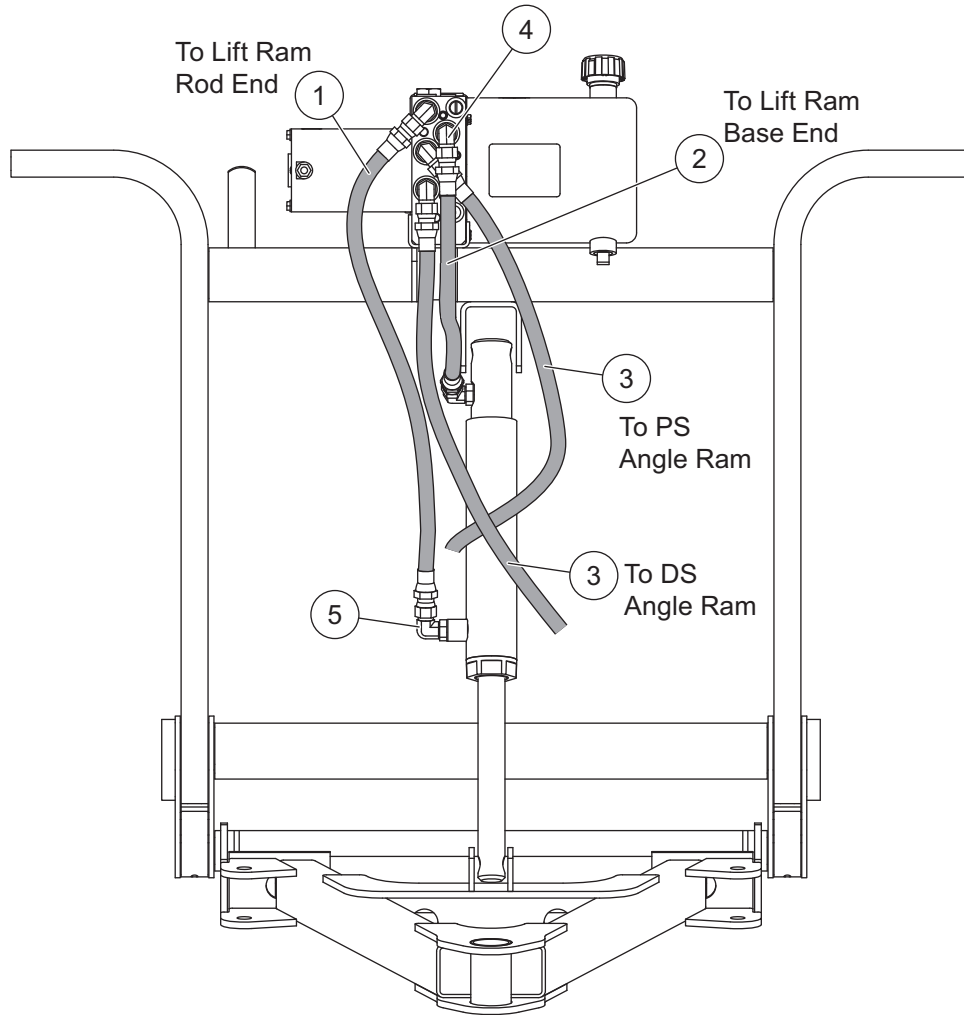

Hoses and Fittings						
Item	Part	Qty	Description	Item	Part	Qty Description
1	56598	1	1/4 x 22 Hose (FJIC Ends)	4	44361	1 Elbow, Long 90° -6
2	44311	1	1/4 x 12 Hose (FJIC Ends)	5	56725	7 Elbow 90° -6
3	56599	2	1/4 x 36 Hose (FJIC Ends)			

F = Female

27517-1, 27550

**Vehicle-Side Harness Diagram
3-Port, 3-Plug System**

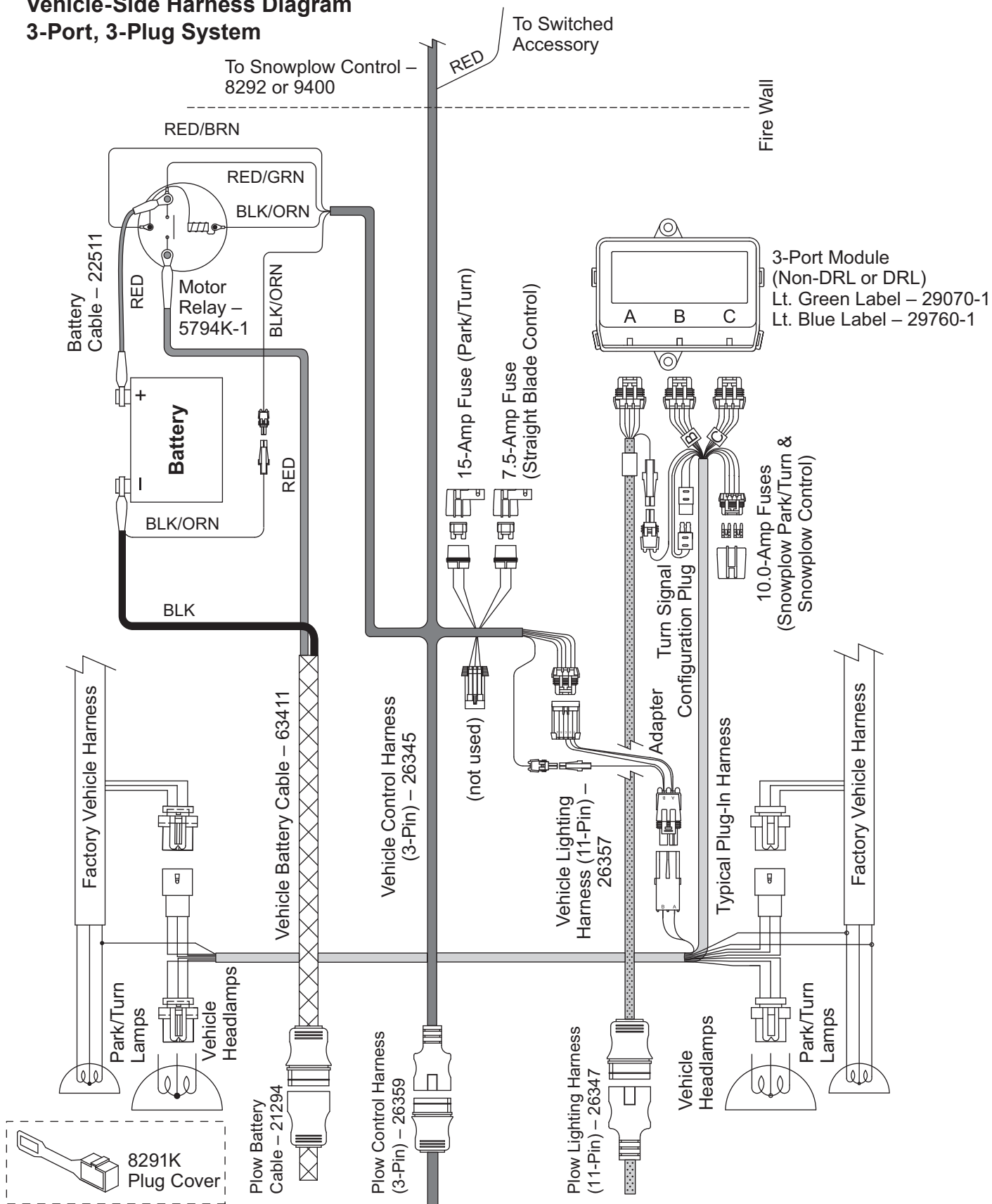

Copyright © 2009 Douglas Dynamics, L.L.C. All rights reserved. This material may not be reproduced or copied, in whole or in part, in any printed, mechanical, electronic, film or other distribution and storage media, without the written consent of Fisher Engineering. Authorization to photocopy items for internal or personal use by Fisher Engineering outlets or snowplow owner is granted.

Fisher Engineering reserves the right under its product improvement policy to change construction or design details and furnish equipment when so altered without reference to illustrations or specifications used. Fisher Engineering or the vehicle manufacturer may require or recommend optional equipment for snow removal. Do not exceed vehicle ratings with a snowplow. Fisher Engineering offers a limited warranty for all snowplows and accessories. See separately printed page for this important information. The following are registered (®) or unregistered (™) trademarks of Douglas Dynamics, L.L.C.: FISHER®, Homesteader™.

Printed in U.S.A.
