



# WIDE-OUT™ Snowplow

Blade Assembly 52810

H,A,Q&L Center Assembly 52225

Parts List





**www.storksplows.com**  
**TABLE OF CONTENTS**

---

**WIDE-OUT™ BLADE** ..... 1

**WIDE-OUT HYDRAULIC, A-FRAME, QUADRANT & LIFT FRAME (H,A,Q&L) CENTER ASSEMBLY** ..... 3

    Lift Frame and A-Frame ..... 3

    Hydraulic Unit ..... 5

    Cover Assembly ..... 7

    Lift and Angle Rams ..... 8

    Hoses and Fittings ..... 8

    Electrical Components ..... 9

    Vehicle-Side Wiring Diagram ..... 10

    Headlamp Kit ..... 12

Blade Components

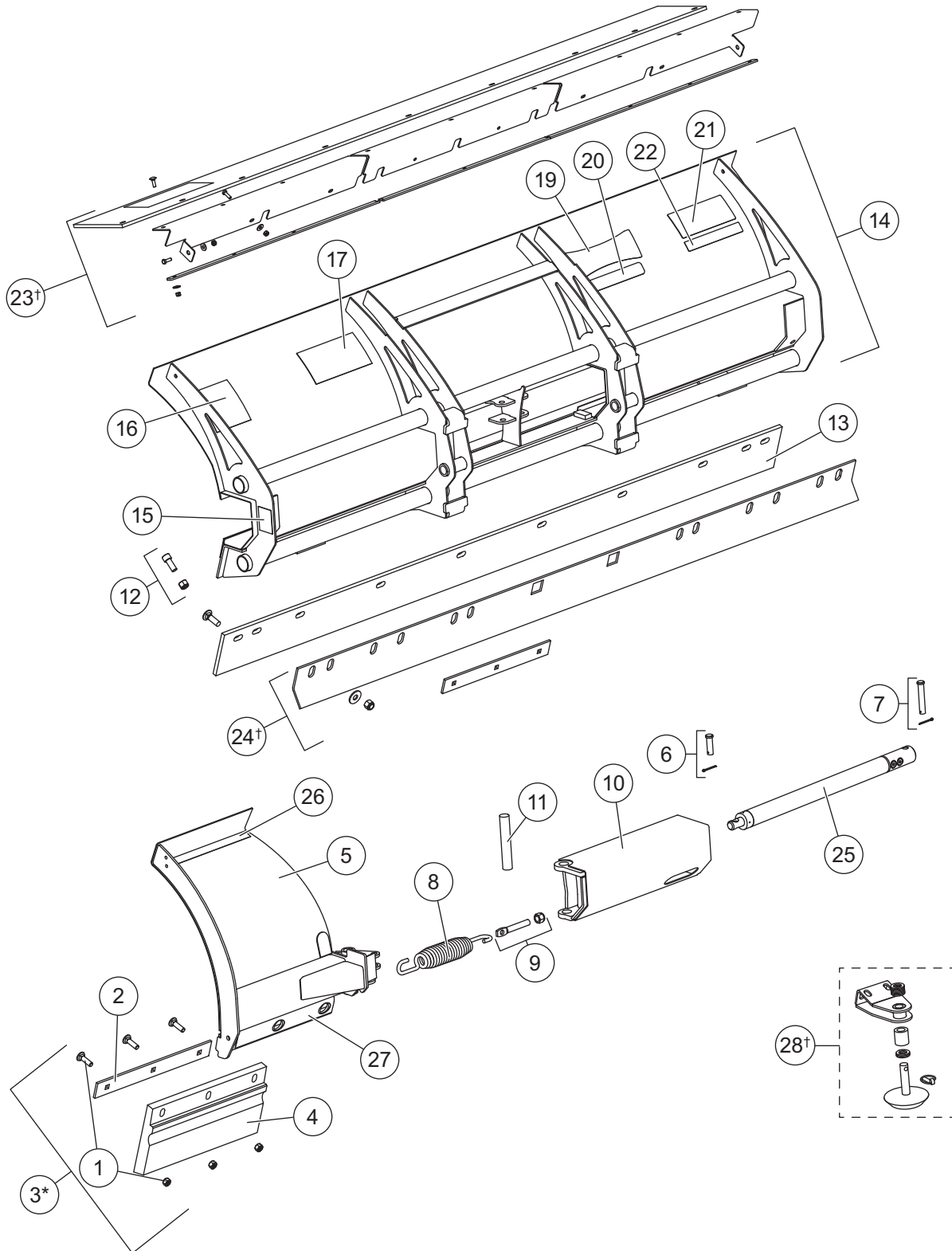

\* Does not include Retainer Bar (Item 2)  
† = Accessory Only

**www.storksplows.com**  
**WIDE-OUT™ BLADE 52810**

WIDE-OUT Blade Components					
Item	Part	Description	Item	Part	Description
1	50642	Bolt Kit, Urethane Edge	15	29593	Label, Multiple Pinch Points
2	50644	Retainer Bar	16	59900	Label, Warning/Caution - Snowplows
3	50626	Kit, Urethane Edge Assy (Does not include Retainer Bar)	17	67796	Label, UltraMount® Attach/Detach
4	50645	Urethane Edge	19	50617	Label, WIDE-OUT ID
5	50649	DS Blade Wing, WIDE-OUT	20	28404	Label, Identity ULTRAFINISH™
ns	50650	PS Blade Wing, WIDE-OUT	21	44451	Label, Identity WESTERN® 8.31
6	50651	5/8 x 2 Pin Kit	22	50603	Label, 8'-10' WIDE-OUT
7	50653	5/8 x 3 Pin Kit	23†	52280	Deflector Kit, WIDE-OUT
8	50654	Wing Spring	24†	52278	Back Drag Kit, WIDE-OUT
9	66421	5/8-11 x 4 Eyebolt Kit	25	B60347	Hydraulic Cylinder, Slide Box
10	50658	DS Blade Slidebox, WIDE-OUT	ns	B60373	Combo Seal Kit, Cylinder B60374
ns	50659	PS Blade Slidebox, WIDE-OUT	26	50639	Wear Strip – Wing Top
11	50660	Wing Pin	27	50638	Wear Strip – Wing Bottom
12	50661	Stop Bolt Kit	28†	44277-1	Shoe Kit – Set of 2
13	64775	Cutting Edge Kit	ns	50618	Label, WIDE-OUT Wings
14	50667	WIDE-OUT Blade	ns	40986	Label, Identity – CONTRACTOR GRADE®
ns = not shown			† = Accessory Only		

# WIDE-OUT™ H,A,Q&L CENTER ASSEMBLY 52225

## Lift Frame and A-Frame Components

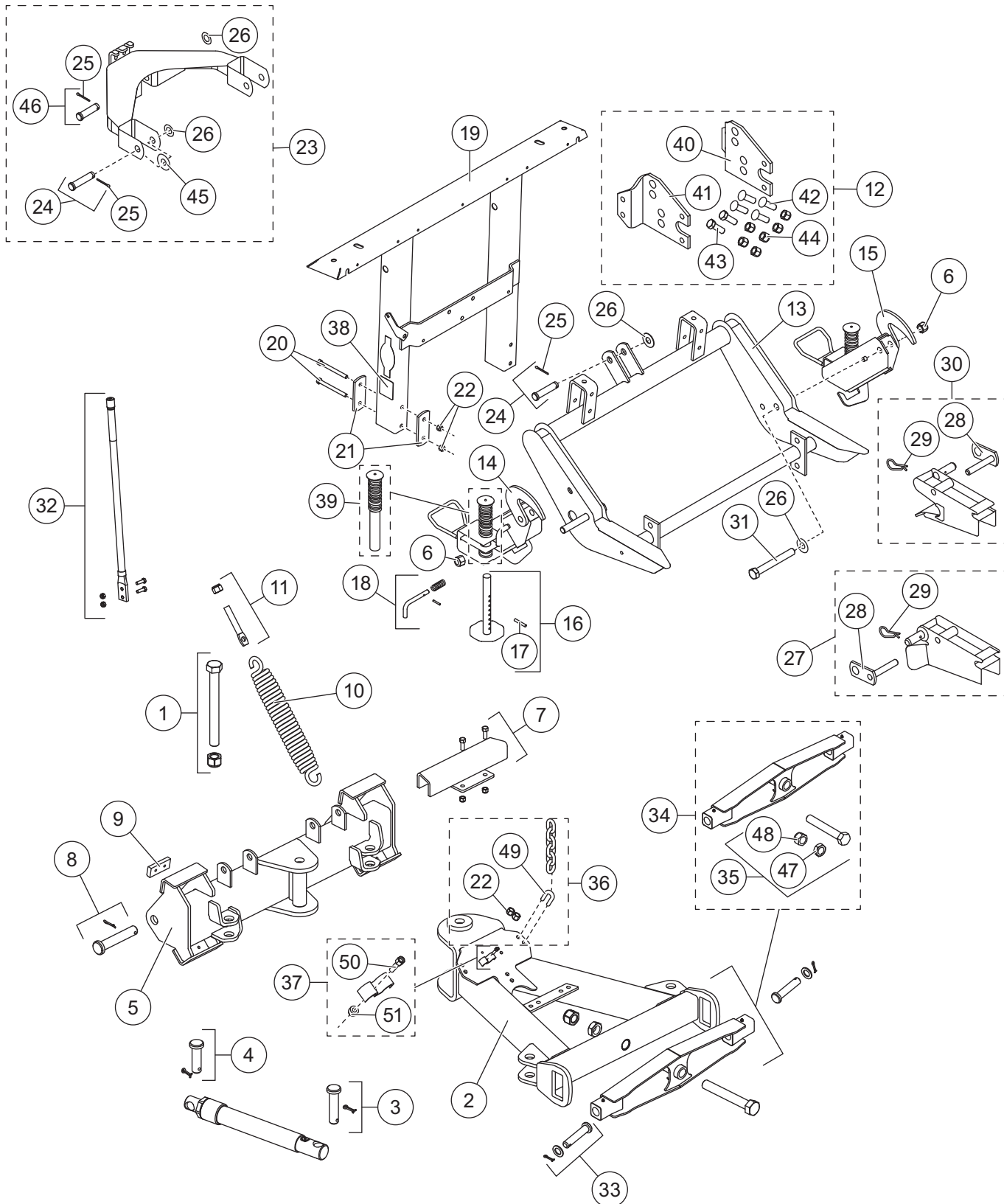

**WIDE-OUT™ H,A,Q&L CENTER ASSEMBLY 52225**

<b>WIDE-OUT Lift Frame and A-Frame Components</b>							
<b>Item</b>	<b>Part</b>	<b>Qty</b>	<b>Description</b>	<b>Item</b>	<b>Part</b>	<b>Qty</b>	<b>Description</b>
1	50668	1	Kit, Pivot Bolt	21		4	Plate – Upper Lift Frame
2	50670	1	Kit, A-Frame	22	91333	4	3/8-16 Hex Locknut GB
3	50672	2	Pin Kit, Base End	23	67850-1	1	Lift Arm Kit
4	50674	2	Pin Kit, Rod End	24	93063K	3	3/4 x 3-1/4 Clevis Pin Kit
5	50675	1	Quadrant Assy, WIDE-OUT	25	91911K	4	5/32 x 1-1/2 Cotter Pin
6	91338	6	3/4-10 Hex Locknut GB	26	91147	6	3/4 Flat Washer
7	50676	1	Kit, Stacking Stop	27	67858	1	Receiver Kit DS
8	50677	2	Pin Kit	28	67665	2	Receiver Pin
9	63976	4	Kit, Bumper	29	91965K	2	5/32 Hairpin Cotter
10	23039	4	Trip Spring	30	67859	1	Receiver Kit PS
11	66421	4	Eyebolt Kit	31	66451	2	3/4-10 x 6 Hex Cap Screw G5
12	67843	1	Pivot Plate Service Kit	32	62595	1	Blade Guide Assembly Poly– 24"
13	67556-2	1	Lower Lift Frame	33	49645	2	1 x 4-3/4 Clevis Pin Kit
14	67845	1	Stand Assembly DS	34	67842-1	1	Pivot Bar Kit
15	67846	1	Stand Assembly PS	35	67855	1	Pivot Bolt Kit
16	67847	2	Stand Shoe Kit	36	49033	2	1/4 Grade 43 Chain Assembly
17	67635	2	1/4 x 2 Roll Pin BP	37	49479	2	Hose Bracket Kit
18	67844	2	Stand Lock Pin Kit	38	69689	1	Label – SECURITY GUARD™
19	44545-2	1	Upper Lift Frame	39	48523	1	Plunger w/ Spring
20		4	3/8-16 x 4 Hex Cap Screw G8				
<b>Item 12</b>				<b>67843 Pivot Plate Service Kit</b>			
40	67707	1	Pivot Plate A	43	90127	2	5/8-11 x 1-1/2 Hex Cap Screw G5
41	67708	1	Pivot Plate B	44	91337	6	5/8-11 Hex Locknut GB
42	5572	4	5/8-11 x 2 Carriage Bolt G5				
<b>Item 23</b>				<b>67850-1 Lift Arm Kit</b>			
		1	Lift Arm	26	91147	3	3/4 Flat Washer
24	93063K	2	3/4 x 3-1/4 Clevis Pin Kit	45	67727-1	2	Round Flat Washer – Special
25	91911K	3	5/32 x 1-1/2 Cotter Pin	46	64617	1	3/4 x 3 Clevis Pin Kit
<b>Item 34</b>				<b>67842-1 Pivot Bar Kit</b>			
		1	Pivot Bar	35	67855	1	Pivot Bolt Kit
<b>Item 35</b>				<b>67855 Pivot Bolt Kit</b>			
		1	1-8 x 7 Hex Cap Screw G5	48	91340	1	1-8 Hex Locknut GB
47	67748	1	1-8 Hex Jam Nut G5				
<b>Item 36</b>				<b>49033 1/4 Grade 43 Chain Assembly (2 Per Plow)</b>			
		1	1/4 Grade 43 Chain	49	90571	1	3/8-16 x 1-1/2 U-Bolt
22	91333	2	3/8-16 Hex Locknut GB				
<b>Item 37</b>				<b>49479 Hose Bracket Kit (2 Per Plow)</b>			
		1	Hose Bracket	51	91331	1	1/4-20 Hex Locknut GB
50	44880	1	1/4-20 x 1-1/4 Socket Cap Screw G5				
ns = not shown				G = Grade			

WIDE-OUT™ H,A,Q&L CENTER ASSEMBLY 52225

Hydraulic Unit Components

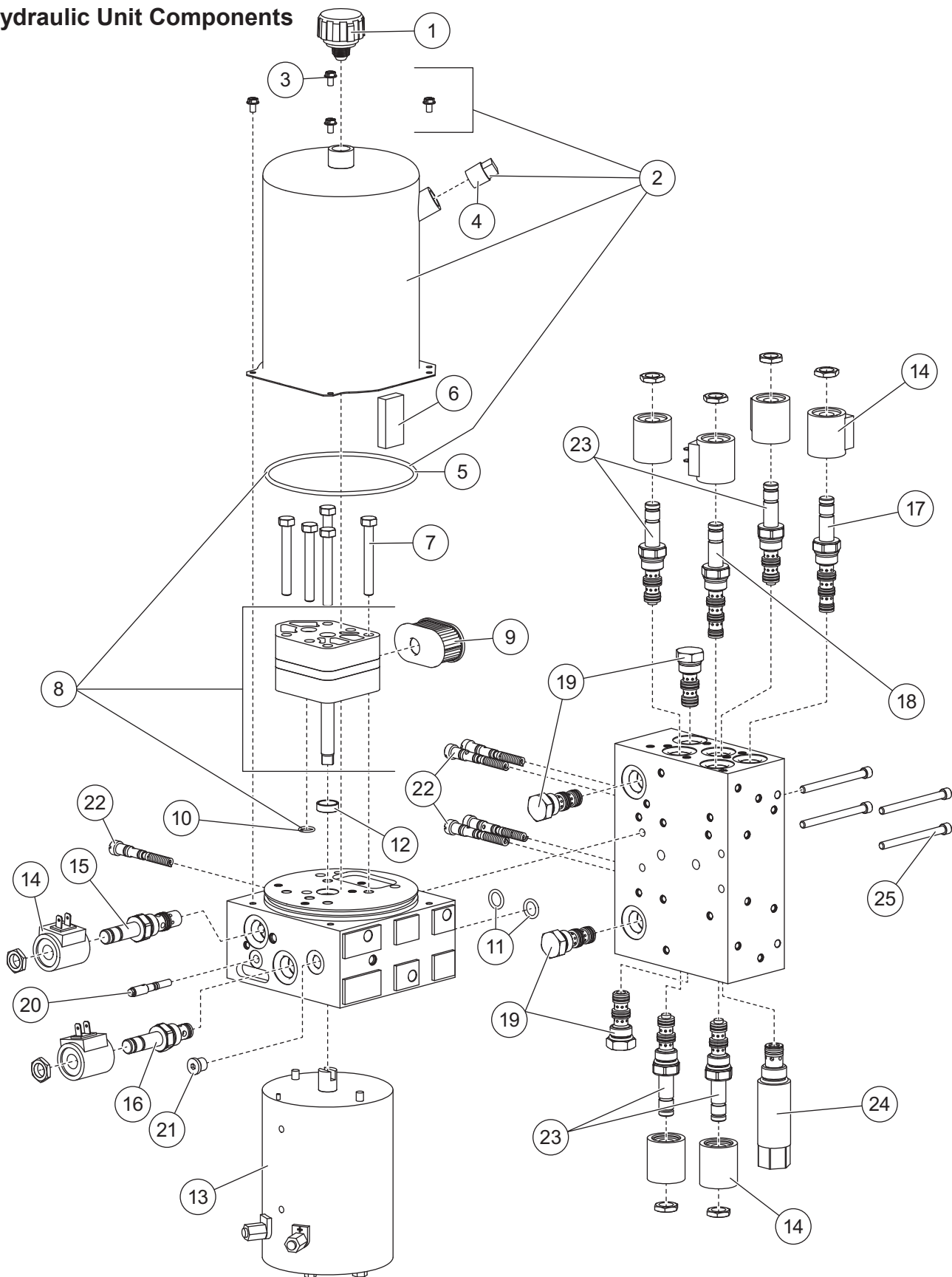



**WIDE-OUT™ H,A,Q&L CENTER ASSEMBLY 52225**

49450 Hydraulic Unit WIDE-OUT							
48256 Hydraulic Unit Service Kit WIDE-OUT*							
Item	Part	Qty	Description	Item	Part	Qty	Description
1	21727-2K	1	Breather Pressure Control	17	49452	1	Valve – SV08-45 w/Nut
2	44327-1	1	Reservoir Kit	18	49456	1	Valve – SV08-41 w/Nut
3	66607	4	10-24 x 5/16 Machine Screw	19	49458	4	Valve – PC08-30 w/Nut
4	92079	1	3/8 Plug NPTF Square	20	56662	1	Quill Assembly 5/16-24 Thread
5	66519	1	O-Ring 2-250		48517	1	Quill Assembly 1/2-20 Thread
6	73897	1	Magnet	21	44344	1	7/16-20 Socket O-Ring Boss Plug
7	90080	5	5/16-18 x 2-1/2 Hex Cap Screw G5	22	49138K-3	2-1/2	Relief Valve Kit – 2 Sets
8	44328-1	1	Pump Kit	23	49228K-1	4	Cartridge 30 W/Jam Nut
9	56789-3	1	Suction Filter	24	49462	1	Crossover Relief Valve – 4000 psi
10	56274	1	O-Ring – 013	25	29081	4	1/4-20 x 3 Socket Cap Screw
11	44905	2	O-Ring – 112	ns	29099	2	1/4-20 x 1/4 Hex Washer-Head Thread-Rolling Screw
12	66515	1	Pump Shaft Seal	ns	44326	1	1/4-20 x 1/2 6-Lobe Round Washer-Head Screw (Package of 5)
13	21500-1	1	Motor Assembly 4-1/2"	ns	44355	2	1/4-20 x 5/8 Hex Washer-Head Thread-Rolling Screw
14	49230K-2	8	Coil With Spade Terminals				
15	44332	1	Valve – SVCV08-20 w/Nut				
16	49227K-2	1	Valve – SV08-2004 w/Nut				
O-Ring Service Kits							
–	56657-3	–	Back-Up/O-Ring Kit (Does not contain O-Rings for cartridge valves.)	–	49259-2	–	Seal Kit – Valves SV08-30, 31, 33, 40, 41, 43, 45, SVCV08-20 & PC08-30
–	49258-2	–	Seal Kit – Valves SV08-2004, CV08-20, SF08-2015		49464		Seal Kit – Crossover Relief Valve
ns = not shown				G = Grade			

\* includes 49450 Hydraulic Unit, 49455 Cover Assembly (p. 7) and Plow-Side Electrical Components (p. 9)

WIDE-OUT™ H,A,Q&L CENTER ASSEMBLY 52225

Hydraulic Unit Cover Assembly

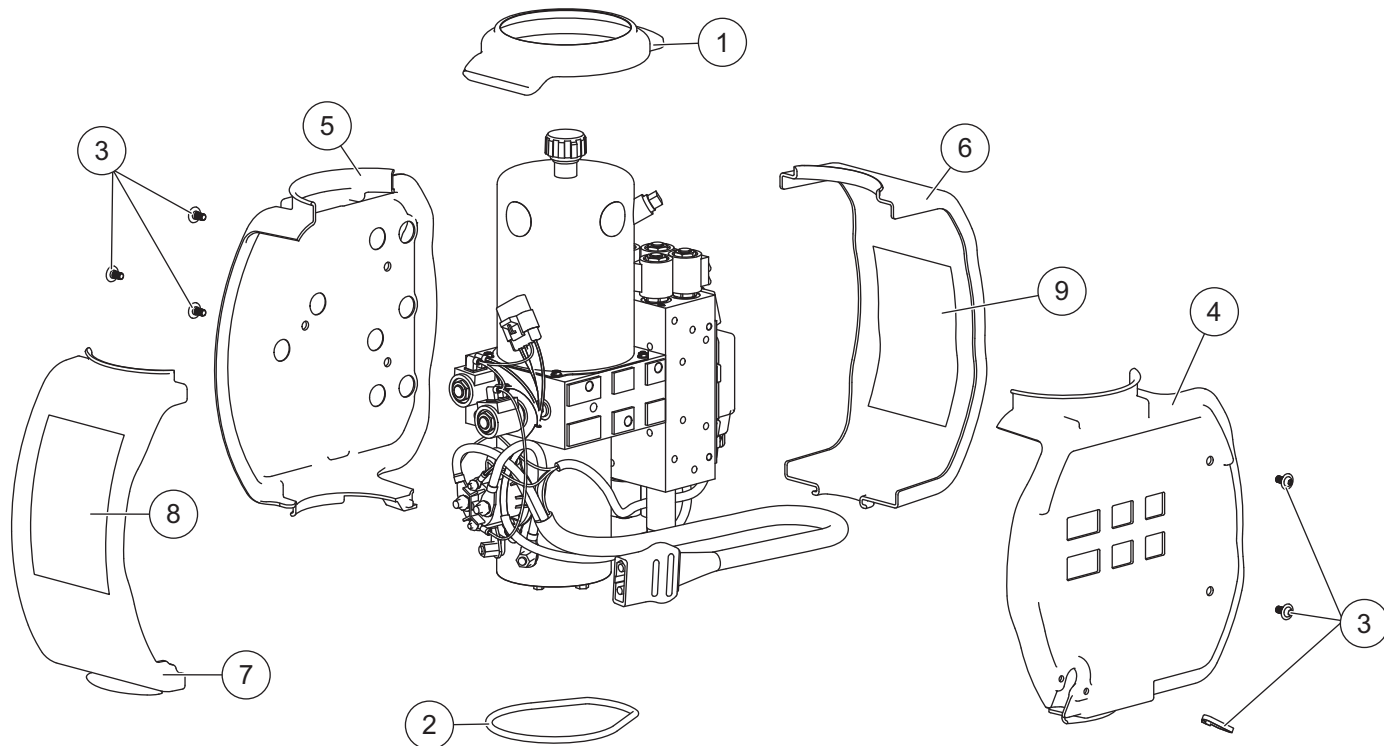

49455 Cover Assembly							
Item	Part	Qty	Description	Item	Part	Qty	Description
1	44352	1	Top Retainer Ring	6		1	Cover Side 03
2	44366	1	Bottom Retainer Ring	7		1	Cover Side 04
3	44326	1	1/4-20 x 1/2 6-Lobe Round Washer-Head Screw (5-Pack) w/8" Cable Tie	8	44904	1	Label, Information
4		1	Cover Side 01	9	44906	1	Label, Information
5		1	Cover Side 02	ns	49445	1	Label, Identity
				ns	61536	1	Cable Tie – 14"

ns = not shown

**WIDE-OUT™ H,A,Q&L CENTER ASSEMBLY 52225**

**Lift and Angle Ram Components**

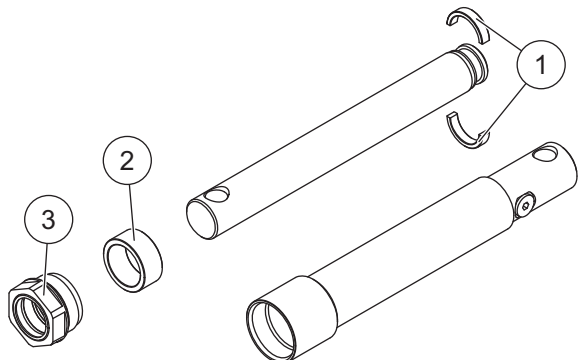

56538K Lift Ram Assembly 1-1/2 x 8			
Item	Part	Qty	Description
1	62290	2	Split Bearing 1-1/2"
2	56537	1	Spacer
3	48985	1	Gland Nut Assembly

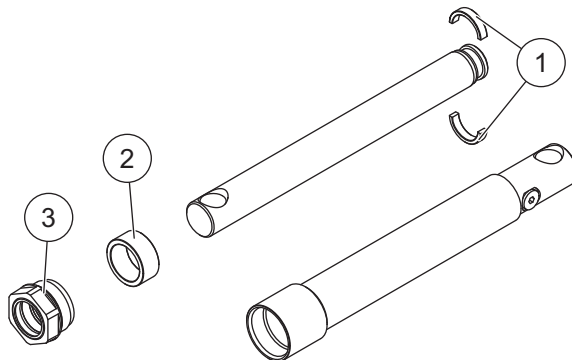

49460 Angle Ram Assembly 1-1/2 x 10			
Item	Part	Qty	Description
1	62290	2	Split Bearing 1-1/2"
2	56537	1	Spacer
3	48985	1	Gland Nut Assembly

**Hoses and Fittings**

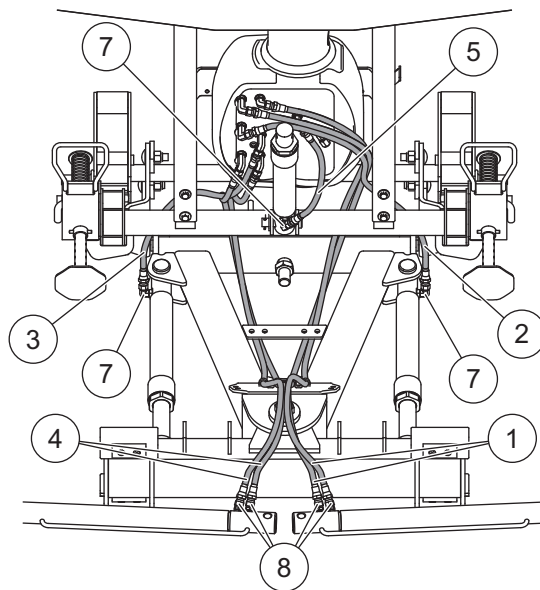
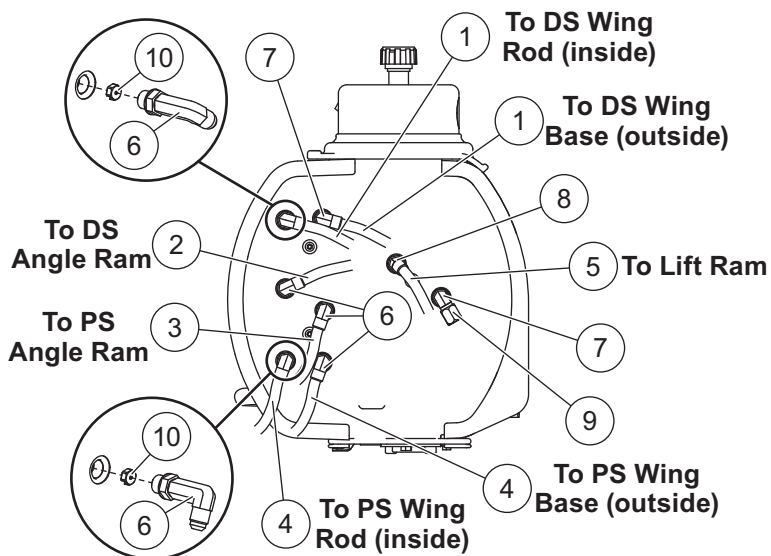

Hoses and Fittings							
Item	Part	Qty	Description	Item	Part	Qty	Description
1	49468	2	3/8 x 78 Hose w/FJIC Ends	8	26694	5	Elbow 45° – 6M O-Ring/MJIC
2	44351	1	3/8 x 38 Hose w/FJIC Ends	9	44346	1	Drain Cap, Flare Tube End – 6M
3	49469	1	3/8 x 32 Hose w/FJIC Ends	10	49465	2	Orifice Kit
4	49467	2	3/8 x 67 Hose Kit w/FJIC Ends	ns	56823	5	Hose Wrap, Polyethylene
5	56617	1	1/4 x 16 Hose Kit w/FJIC Ends	ns	98043	3	3/8-16 x 1 Button Cap Screw
6	64212-1	5	Elbow 90° Long – 6M O-Ring/MJIC	ns	B63263	4	Label – Hose Install Warning
7	56615-1	5	Elbow 90° – 6M O-Ring/MJIC				
F = Female				ns = not shown			
				M = Male or Metric			

**WIDE-OUT™ H,A,Q&L CENTER ASSEMBLY 52225**

**Electrical Components**

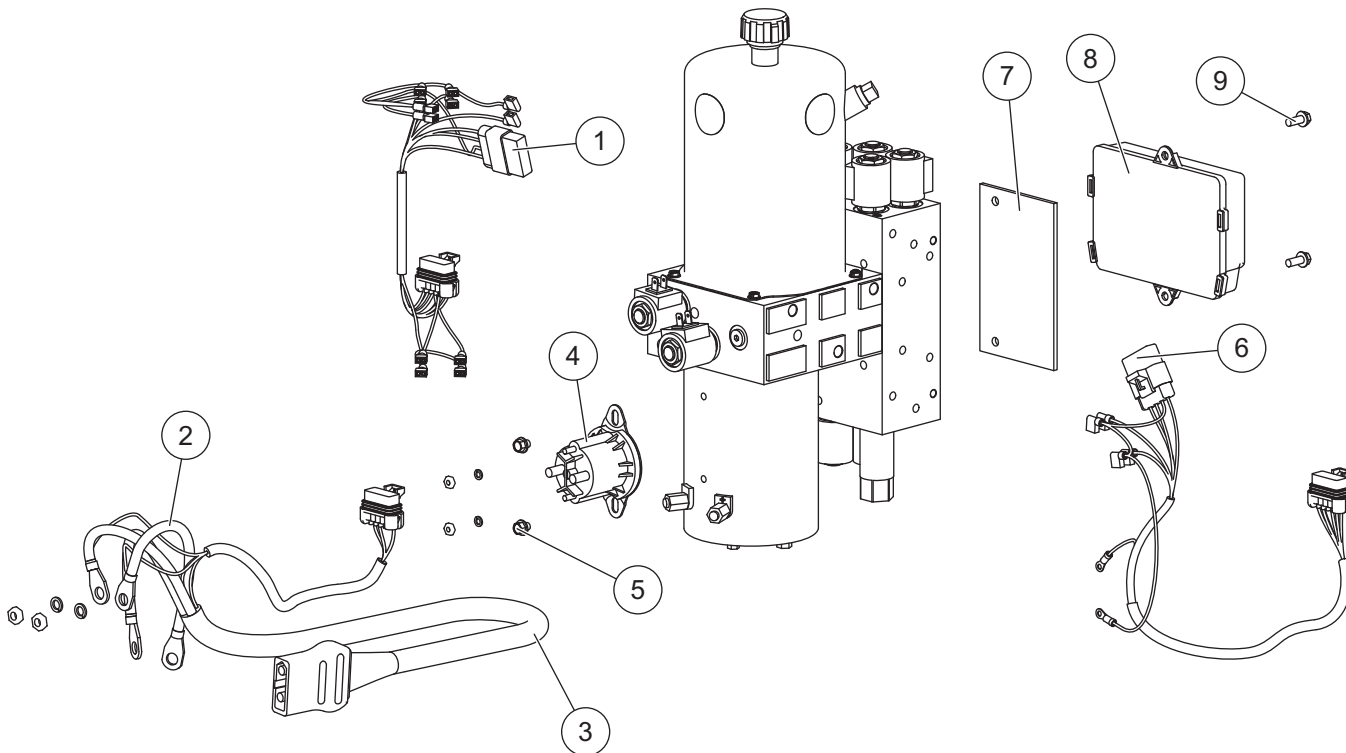

Plow-Side Electrical Components						
Item	Part	Qty	Description	Item	Part	Qty Description
1	29471	1	Harness Plow Control 6 Solenoid	8	44354-3	1 Plow Module
2	29071	1	Cable Assembly 8"	9	44355	2 1/4-20 x 5/8 Hex Washer-Head Thread-Rolling Screw
3	42015	1	Plow Battery Cable	ns	61246	1 Cable Boot
4	56131K-2	1	Motor Relay Kit	ns	56099	1 Dielectric Grease
5	29099	2	1/4-20 x 1/4 Hex Washer-Head Thread-Rolling Screw	ns		4 Fuse – 4-Amp Mini Automotive Blade-Style (for items 1 & 6)
6	29461	1	Harness Plow Control 2 Solenoid			
7	44308		Spacer Module			
Vehicle-Side Electrical Components						
*	42014	1	Vehicle Battery Cable	ns	61548K	1 Plug Cover Kit
*	28587	1	Vehicle Control Harness			

ns = not shown

\* = For Diagram See Vehicle-Side Harness Diagram.

Vehicle-Side Harness Diagram  
3-Port, 2-Plug System

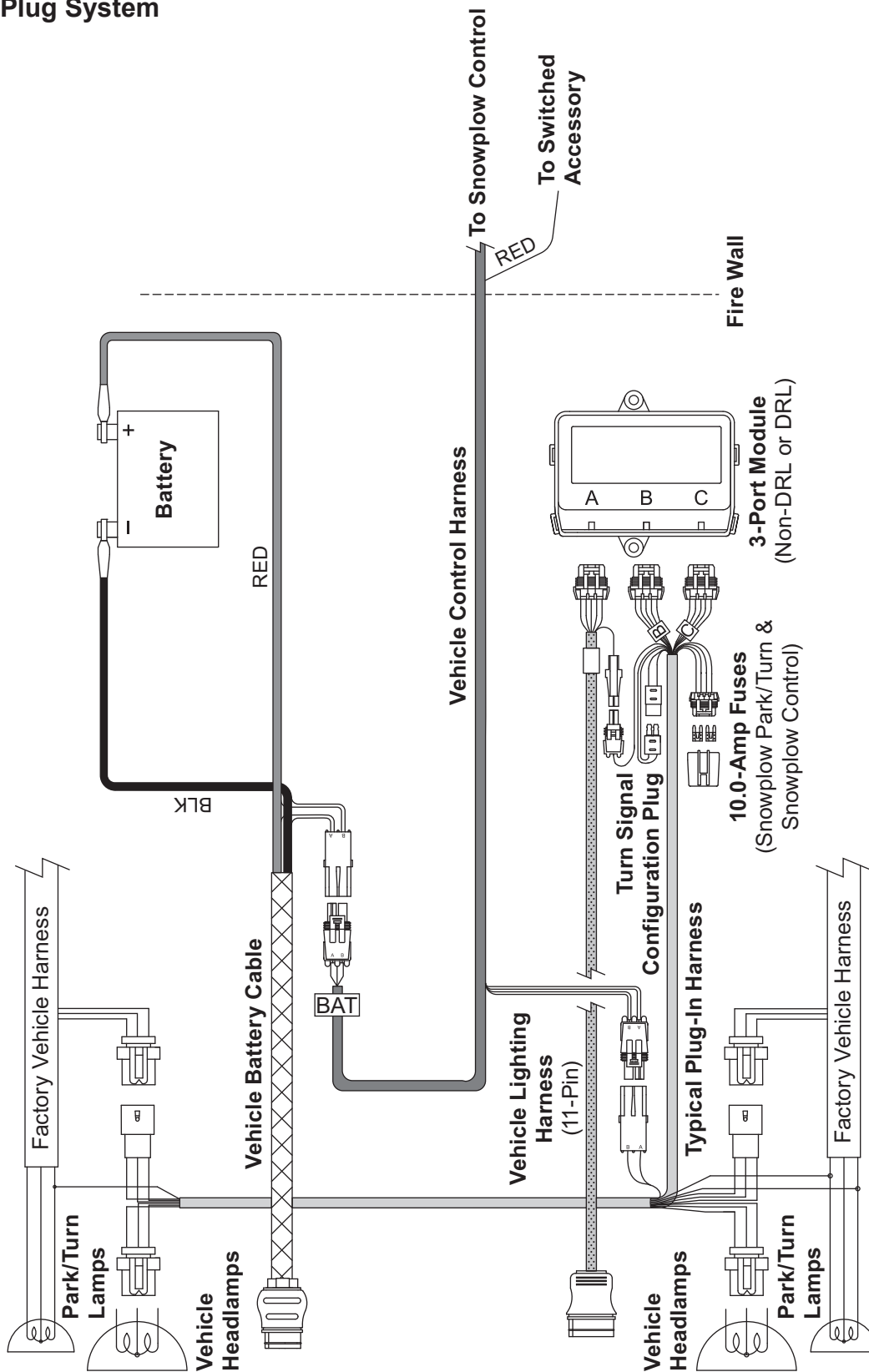

WIDE-OUT™ H,A,Q&L CENTER ASSEMBLY 52225

Headlamp Kit

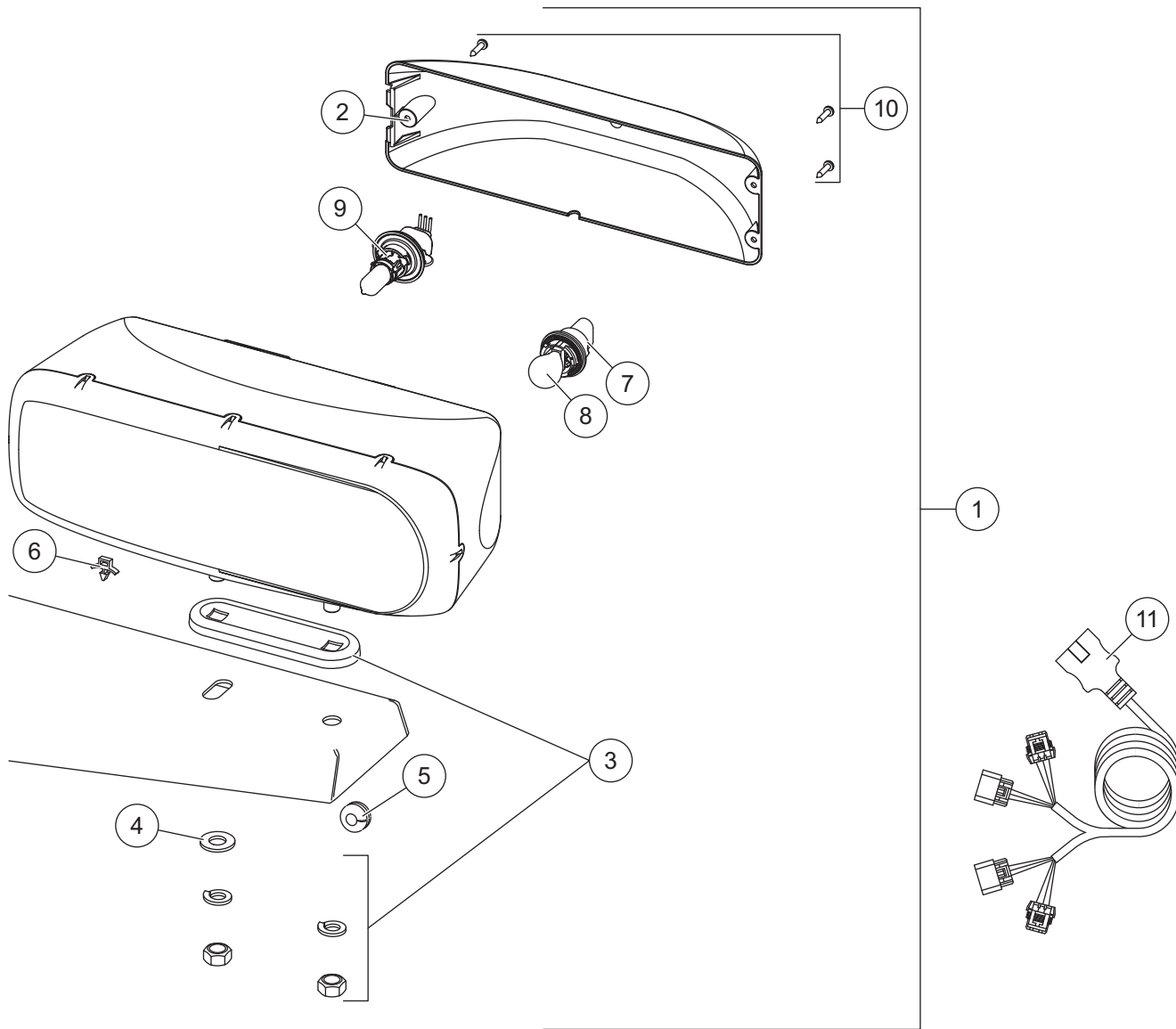

28800-1 Headlamp Kit (Pair)							
Item	Part	Qty	Description	Item	Part	Qty	Description
1	28801-1	1	Headlamp Service Kit – DS	6	56595	7	Cable Tie Anchor
ns	28802-1	1	Headlamp Service Kit – PS	7	28805	2	Park/Turn Socket Service Kit
2	28803-1	2	Rear Cover Kit (fits 2 or 3 screw)	8		2	Park/Turn Bulb (Trade No. 4157NAK)
3	28804	2	Mounting Hardware Kit	9	28806	2	H13 Headlamp Bulb Service Kit
4	56558	2	1/2 Flat Washer Special	10	28808-1	2	Cover Screws Service Kit (3 screws)
5	66130	2	Rubber Grommet	11	28213W	1	Harness Service Kit

ns = not shown





Western Products  
PO Box 245038  
Milwaukee, WI 53224-9538  
www.westernplows.com

 A DIVISION OF DOUGLAS DYNAMICS, L.L.C.

Copyright © 2011 Douglas Dynamics, L.L.C. All rights reserved. This material may not be reproduced or copied, in whole or in part, in any printed, mechanical, electronic, film or other distribution and storage media, without the written consent of Western Products. Authorization to photocopy items for internal or personal use by Western Products outlets or snowplow owner is granted.

Western Products reserves the right under its product improvement policy to change construction or design details and furnish equipment when so altered without reference to illustrations or specifications used. Western Products or the vehicle manufacturer may require or recommend optional equipment for snow removal. Do not exceed vehicle ratings with a snowplow. Western Products offers a limited warranty for all snowplows and accessories. See separately printed page for this important information. The following are registered (®) or unregistered (™) trademarks of Douglas Dynamics, L.L.C.: CONTRACTOR GRADE®, SECURITY GUARD™, ULTRAFINISH™, UltraMount®, WESTERN®, WIDE-OUT™.

Printed in U.S.A.