

FLEETFLEX

ELECTRICAL SYSTEM

Joystick Control

For the FLEET FLEX Electrical System

Installation Instructions

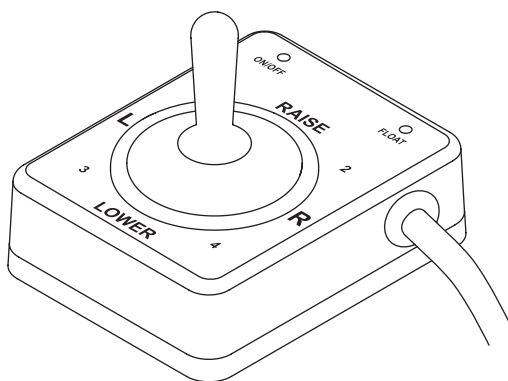

**Straight Blade & SPEEDWING™
Joystick Control**

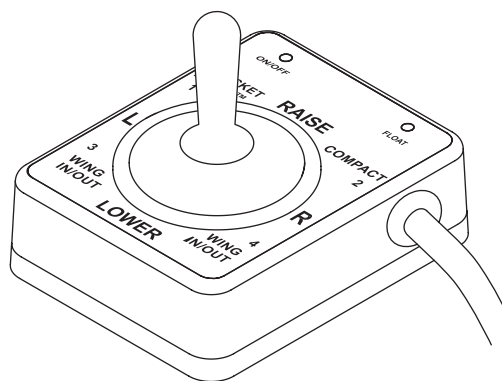

POWER PLOW™ Joystick Control

⚠ CAUTION

Read this document before installing the control.

⚠ CAUTION

Use standard methods and practices when attaching snowplow and installing accessories, including proper personal protective safety equipment.

⚠ CAUTION

See your SnowEx® outlet/Web site for specific vehicle application recommendations before installation. The Power Match selection system has specific vehicle and snowplow requirements.

SAFETY DEFINITIONS

⚠ WARNING

Indicates a potentially hazardous situation that, if not avoided, could result in death or serious personal injury.

⚠ CAUTION

Indicates a potentially hazardous situation that, if not avoided, may result in minor or moderate injury. It may also be used to alert against unsafe practices.

NOTE: Indicates a situation or action that can lead to damage to your snowplow and vehicle or other property. Other useful information can also be described.

84450, 84460

FUSES

The SnowEx® electrical and hydraulic systems contain several blade-style automotive fuses. If a problem should occur and fuse replacement is necessary, the replacement fuse must be of the same type and amperage rating as the original. Installing a fuse with a higher rating can damage the system and could start a fire. Fuse Replacement, including fuse ratings and locations, is located in the Maintenance section of the Owner's Manual.

NOTE: The controls do not contain onboard fuses. Consult your snowplow Owner's Manual for fuse replacement. Fuses are located both under the hood and on the hydraulic unit.

NOTE: Circuit board may be damaged by static electricity. Always touch ground before handling PC board.

CONTROL BRACKET PLACEMENT

⚠ CAUTION

Do not alter, modify, or install additional components in shaded areas of the illustration below. Failure to comply may interfere with air bag deployment or cause injury to operator in an accident.

When mounting the control bracket, choose a location that is within easy reach of the vehicle operator and does not restrict access to vehicle controls or vehicle instrumentation. Do not mount the control in areas prohibited by the vehicle manufacturer for crashworthiness. See the vehicle's body builder's book, owner's manual, or service manual for details. The shaded areas in the illustration below show the most commonly restricted areas.

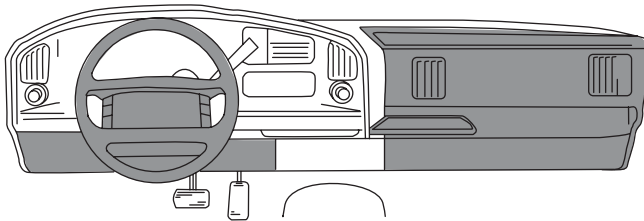

INSTALLING DASH BRACKET

⚠ CAUTION

Before drilling holes, check to be sure that no vehicle wiring or other components could be damaged.

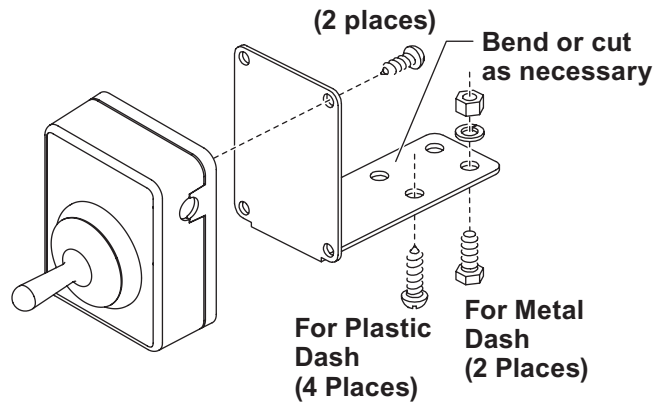

Plastic Dash Only:

1. Using the four clearance holes on the narrow end of the bracket as guides, drill four 9/64" tap holes in the dash.
2. Attach the bracket to the dash with four #12 x 3/4" self-tapping screws.

Metal Dash Only:

1. Using two of the four clearance holes on the narrow end of the bracket as guides, drill two 9/32" holes in the dash.
2. Attach the control to the control bracket with two #8 x 5/8" self-tapping screws, or with the PRO-GRIP Mount Kit (PN 49305K) as instructed.
3. Attach the bracket to the dash with two 1/4" x 3/4" cap screws, 1/4" lock washers and 1/4" nuts.

PRO-GRIP MOUNT KIT

The PRO-GRIP Mount Kit will secure your SnowEx® joystick control to interior vehicle cab surfaces. Possible mounting areas may include front or side of dash, center console, etc. Location will depend on operator preference and mounting clearance with other vehicle controls. Once the control is properly mounted, it can be easily removed and stored.

Installation should be done at temperatures above 60°F (15.6°C).

1. Select the area of the cab where the control will be mounted.
2. Clean installation area and surface of the control with isopropyl alcohol or mineral spirits. Allow the surface to dry for 15 minutes.
3. Determine the length of locking strip required. **Do not obstruct the ON/OFF switch.**

For flat surfaces: Use full length locking strips mounted along the length of the control. Strips may be placed on the back side of the control.

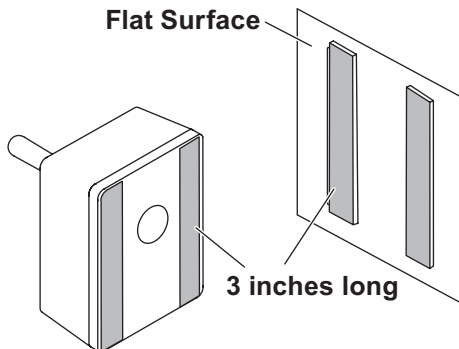

For curved surfaces: Cut the locking strips to 2 inches. These strips must be placed parallel to the curved surface.

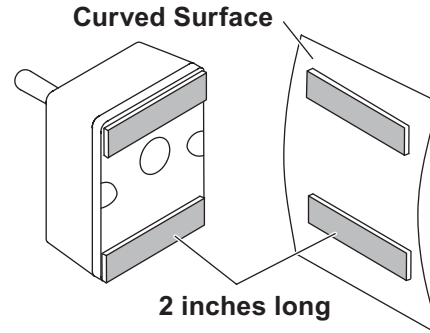

4. Once the selected surfaces are prepared, remove the adhesive back protection strip and press the locking strips into place. Apply pressure across the entire surface to work out any trapped air bubbles.
5. Allow the locking strip adhesive to set for 24 hours before mounting the control to the cab surface.

The control can be easily removed by applying a sideways lifting motion to the control. Do not apply excessive force. If the control does not release, gently pry up in the opening under the control with a screwdriver or other flat object.

The PRO-GRIP locking strips can be removed from the control and mounting location if no longer needed. Adhesive residue can be cleaned up with mineral spirits.

TrynEx International, LLC reserves the right under its product improvement policy to change construction or design details and furnish equipment when so altered without reference to illustrations or specifications used. TrynEx International, LLC or the vehicle manufacturer may require or recommend optional equipment for snow removal. Do not exceed vehicle ratings with a snowplow. TrynEx International, LLC offers a limited warranty for all snowplows and accessories. See separately printed page for this important information. The following are registered (®) or unregistered (™) trademarks of Douglas Dynamics, LLC: POWER PLOW™, SnowEx®, SPEEDWING™.

Printed in U.S.A.
