



## Service Parts for Straight Blades

AQ&L Assemblies  
Hydraulic Assemblies  
Lighting Assemblies



TABLE OF CONTENTS

---

LSX Snowplow Parts Diagram ..... 1

LSX Snowplow Parts List ..... 2

Sport/Utility Snowplow Parts Diagram ..... 3

Sport/Utility Snowplow Parts List ..... 4

STANDARD Steel Snowplow Diagram ..... 5

STANDARD Steel Snowplow Parts List ..... 6

STANDARD POLY PLOW Parts Diagram ..... 7

STANDARD POLY PLOW Parts List ..... 8

POLY PRO-PLOW® Parts Diagram and List ..... 9

PRO-PLOW® Steel Parts Diagram and List ..... 10

A, Q & L (Steel PRO-PLOW and POLY PRO-PLOW Blades) Diagram and Parts List ..... 11

HEAVYWEIGHT Snowplow Parts Diagram ..... 13

HEAVYWEIGHT Snowplow Parts List ..... 14

Solenoid ISARMATIC® Mark IIIA Parts Diagram ..... 15

Solenoid ISARMATIC Mark IIIA Parts List ..... 16

Motor Manufacturer Identification and Service Parts ..... 17

Snowplow Headlamps and Hydra-Turn® Parts Diagram ..... 19

Snowplow Headlamps and Hydra-Turn Parts List ..... 20

Vehicle Components Parts Diagram ..... 21

Blade Component Parts Diagram ..... 21

Vehicle Components Parts List ..... 22

Blade Component Parts List ..... 22

Notes ..... 23

PARTS LIST

LSX Snowplow Parts Diagram

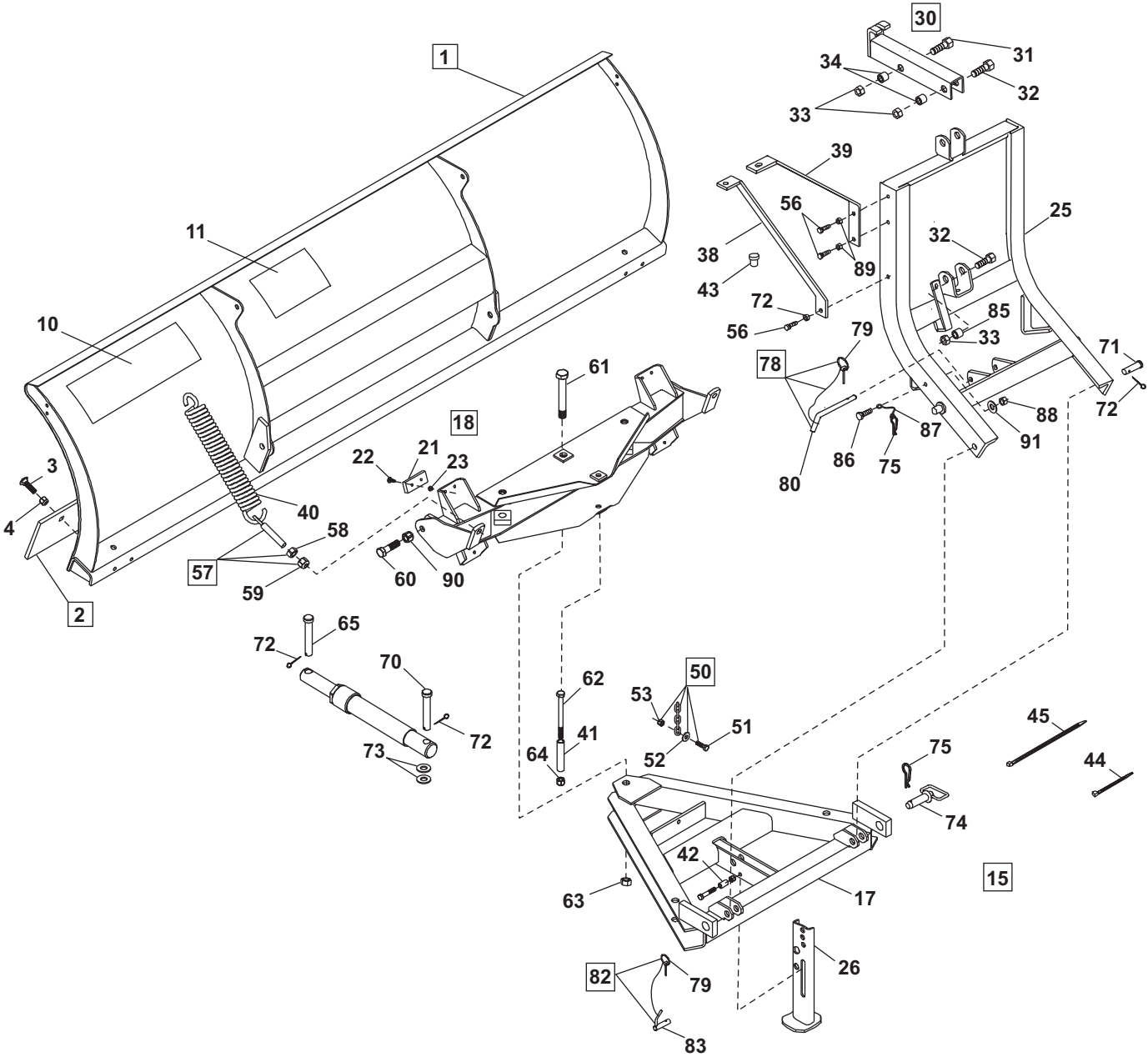

PARTS LIST

LSX Snowplow Parts List

ITEM	PART NO.	QTY.	DESCRIPTION
1	63472	1	BLADE ASSY - 72" LSX
2	63541	1	CUTTING EDGE ASSY 7'-2"
3	90238	8	1/2-13 X 1-3/4 CB G8 BPO
4	91335	8	1/2-13 PT HX LK NUT NYIS ZYC
10	61740	1	LABEL - INFORMATION
11	59900	1	LABEL - INFORMATION (WARNING)
15	-	1	A, Q, & L ASSY U LSX
17	63546	1	A-FRAME
18	63547	1	QUADRANT LSX SERVICE KIT
*	63976	4	BUMPER KIT
25	61903	1	LIFT FRAME U S
26	61353	1	STAND
30	49277	1	LIFT CHANNEL KIT
31	63207	1	3/4-10 X 3-1/4 HX CS G5 ZYC SPL
32	63208	1	3/4-10 X 3-3/4 HX CS G5 ZYC SPL
32	63208	1	3/4-10 X 3-3/4 HX CS G5 ZYC SPL
33	91339	2	3/4-10 PT HX JAM LK NUT NYIS ZYC
33	91339	1	3/4-10 PT HX JAM LK NUT NYIS ZYC
34	63211	2	SPACER .758 ID X 1.0 OD X .5 LG
38	63533	2	LIGHT BRACKET - BOTTOM
39	63532	2	LIGHT BRACKET - TOP
40	23039	2	TRIP SPRING
41	63553	1	BUSHING - STOP
42	61487	1	SPACER .56 OD X .39 ID X .965 LG
43	61482	2	VINYL CAP 1/2 X 1/2
44	59223	4	CABLE TIE
45	61536	3	CABLE TIE -LONG
50	49033	1	REPLACEMENT GRADE 43 CHAIN ASSY
51	66456	1	3/8-16 X 1-1/4 HX CS G5 ZYC
52	91337	1	3/8 PLAIN WASHER TY A SAE ZYC
53	91333	1	3/8-16 PT HX LK NUT NYIS ZYC
56	66456	6	3/8-16 X 1-1/4 HX CS G5 ZYC
57	90490K	2	EYEBOLT KIT
58	91416	1	5/8-11 HX NUT ZYC
59	91337	1	5/8-11 PT HX LK NUT NYIS ZYC
60	90131	2	5/8-11 X 2-1/2 HX CS G5 ZYC
61	63558	1	3/4-10 X 5-1/4 HX CS G5 ZYC SPL (Pivot Bdt)
62	91034	1	1/2-13 X 5-1/2 HX CS G5 ZYC (Stop Bolt)
63	91339	1	3/4-10 PT HX JAM LK NUT NYIS ZYC
64	91335	1	1/2-13 PT HX LK NUT NYIS ZYC
65	63557	2	CLEVIS PIN 3/4" X 4-3/8" HT ZYC
70	93062	2	CLEVIS PIN 3/4" X 3-1/4" HT ZYC
71	93040	2	PIN CLEVIS 5/8 X 2.25 STEEL ZYC
72	91911	6	5/32 X 1-1/2 COTTER PIN ZYC
73	91147	4	PLAIN WASHER TY A SAE ZYC
74	93036	2	1 X 3-1/2 HITCH PIN ZYC U
75	91965	4	HAIRPIN COTTER 5/32"
78	63585	1	STAND PIN ASSY
79	93042K	1	3/16 LINCH PIN ZYC
80	93033K	1	PIN 1/2 X 5.5
82	63586	1	LOCK PIN ASSY
79	93042K	1	3/16 LINCH PIN ZYC
83	93034K	1	STAND LOCK PIN 5/8 X 2.3
85	63212	1	SPACER .758 ID X 1.0 OD X .69 LG
86	63571	2	1/4-20 X 3/4 WLF SCREW ZYC
87	63563	2	LANYARD .05 X 6
88	91331	2	1/4-20 PT HX LK NUT NYIS ZYC
89	91333	6	3/8-16 PT HX LK NUT NYIS ZYC
90	91337	2	5/8-11 PT HX LK NUT NYIS ZYC
91	90311	2	1/4 FLAT WASHER

SERVICE PARTS KITS			
ITEM	PART NO.	QTY.	DESCRIPTION
*	63542	1	STOP BUSHING KIT
41	63553	1	BUSHING - STOP
62	90111	1	1/2-13 X 5-1/2 HX CS G5 ZYC
64	91335	1	1/2-13 PT HX LK NUT NYIS ZYC
*	63976	4	PUSH STOP KIT
21	.	1	BUMPER
22	.	2	1/4-20 X 3/4 SB FLG HD CS BPO
23	.	2	1/4-20 PT HX JAM LK NUT ZYC
*	63544	1	PIVOT BOLT KIT
61	63558	1	3/4-10 X 5-1/4 HX CS G5 ZYC SPL
63	91339	1	3/4-10 PT HX JAM LK NUT NYIS ZYC
*	63545	2	CLEVIS PIN KIT
65	63557	1	CLEVIS PIN 3/4" X 4-3/8" HT ZYC
72	91911	1	5/32 X 1-1/2 COTTER PIN ZYC
*	93062K	2	CLEVIS PIN KIT
70	93062	1	CLEVIS PIN 3/4" X 3-1/4" HT ZYC
72	91911	1	5/32 X 1-1/2 COTTER PIN ZYC
*	93040K	2	CLEVIS PIN KIT
71	93040	1	PIN CLEVIS 5/8 X 2.25 STEEL ZYC
72	91911	1	5/32 X 1-1/2 COTTER PIN ZYC

\* Not Shown  
 Indented parts are included in the assembly under which they are listed. Quantities shown are included with the assembly.

Abbreviations

AD	Adapter	PC	Printed Circuit
A,Q&L	A-Frame, Quadrant & Lift Frame	PH	Phillips Head
ASSY	Assembly	PN	Pan
BP	Black Phosphate	PR	Prestolite
BPO	Black Phosphate & Oil	PS	Passenger Side
BRG	Bearing	PT	Prevailing Torque
BZP	Black Zinc Phosphate	PY	POLY PRO-PLOW® Snowplow
C	Compact Plow	S	Standard Plow
CB	Carriage Bolt	SAE	Society of Automotive Engineers
CS	Cap Screw	SB	Slow Blow (Fuse)
CU	Curb Side	SL	Slotted
DIA	Diameter	SO	Socket Head
DR	Driver Side	SOL	Solenoid
DS	Driver Side	SP	Spring
EA	Each	SPDT	Single Pole Double Throw
FLG	Flange	SPL	Special
FT	Feet	SQ	Square
G	Grade	STD	STANDARD
HD	Heavy Duty	SU	Sport/Utility Plow
HSG	Housing	SY	STANDARD PLOW Poly
HT	Heat Treated	SYS	System
HX	Hex	TCTS	Thread Cutting Tapping Screw
HXW	Hex Washer Screw	TFTS	Thread Forming Tapping
ID	Inside Diameter	TRTS	Thread Rolling Tapping Screw
LG	Long	TP	Tri-Plow
LK	Lock	TY	Type
NPSM	American Standard Straight Pipe Threads for Mechanical Joints	U	UniMount® System
NPTF	National Pipe Thread (Fluid)	W/	With
NYIS	Nylon Insert	W/O	Without
OD	Outside Diameter	WLF	Whiz-Lock Flange
P	PRO-PLOW® Snowplow	ZYC	Zinc Yellow Chromate

Parts listed above may be found in one of the following:  
 63467 1 PARTS BAG ASSY (63470)  
 61579 1 BOLT BAG (A,Q&L COMMON)

PARTS LIST

Sport/Utility Snowplow Parts Diagram

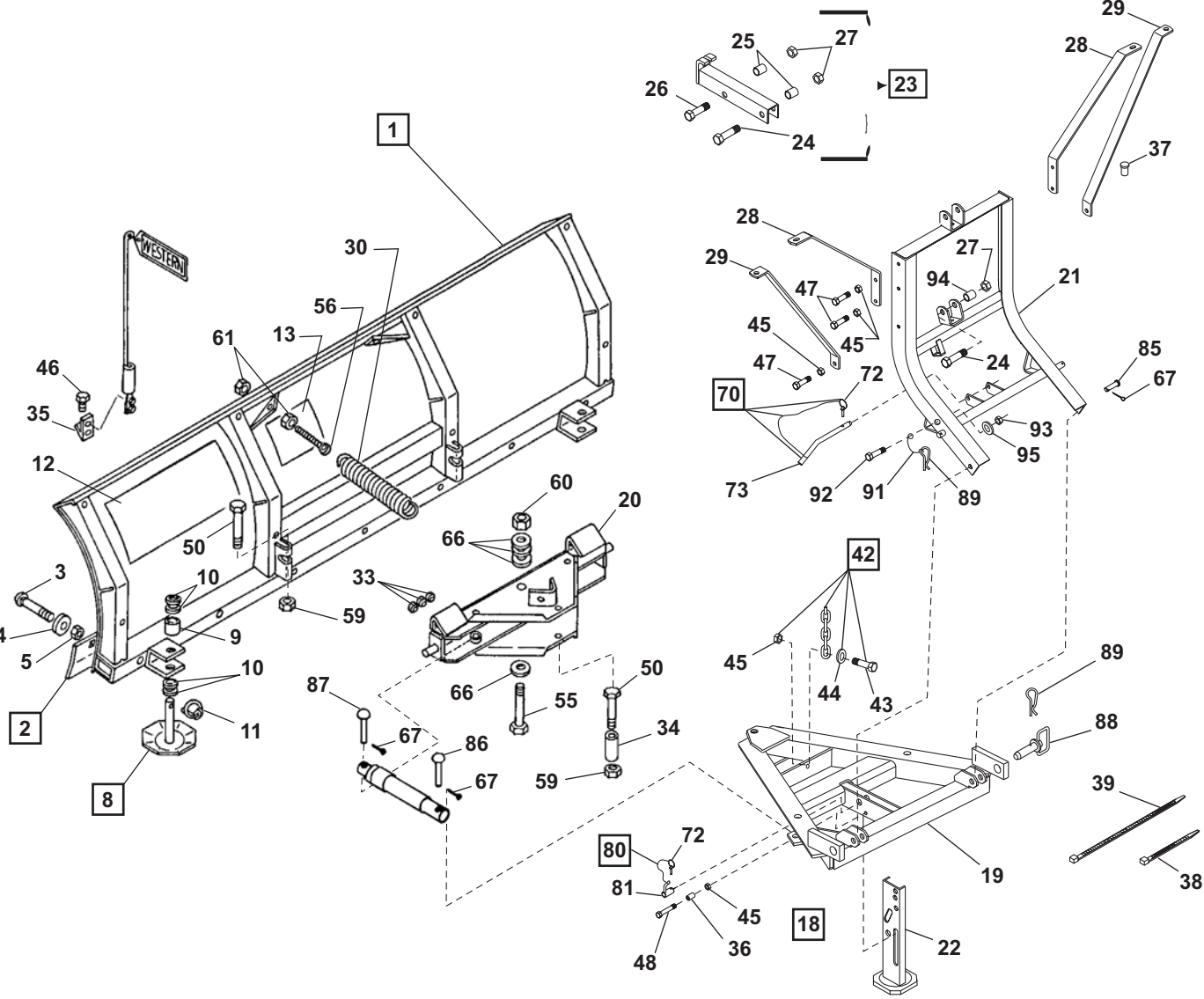

## PARTS LIST

## Sport/Utility Snowplow Parts List

ITEM	PART NO.	QTY.	DESCRIPTION	ITEM	PART NO.	QTY.	DESCRIPTION
1	-	1	6-1/2 FT. BLADE ASSY SU	85	.93040	2	PIN, CLEVIS 5/8 X 2.25 STEEL ZYC
2	.49264	1	CUTTING EDGE ASSY - 6-1/2' SU	86	.93063K	2	RIVET 3/4" X 3-1/2"
3	.. 90229	7	7/16-14X3-1/2 CB G5 ZYC	87	.93061K	2	RIVET 3/4" X 4-1/8" G5 ZYC
4	.. 91104	7	7/16 PLAIN WASHER TY A STD ZYC	88	.93028K	2	HITCH PIN 1" X 3-1/2"
5	.. 91334	7	7/16-14 PT HX LK NUT NYIS ZYC	89	.91965K	4	HAIRPIN COTTER 5/32"
8	.49266	2	DISC SHOE ASSY SU	91	.63563	2	LANYARD .05 X 6
9	.. 60045	1	SPACER	92	.63571	2	1/4-20 X 3/4" WLF SCREW ZYC
10	.. 91192	13	FLAT WASHER - SPECIAL ZYC	93	.91331	2	1/4-20 PT HX LK NUT NYIS ZYC
11	.. 93010K	1	LINCH PIN 7/16" X 1-3/4"	94	.63212	1	SPACER .758 ID X 1.0 OD X .69 LG
12	.61740	1	LABEL - INFORMATION (Link Arm Style)	95	.90311	2	1/4 FLAT WASHER
13	.59900	1	LABEL - INFORMATION (WARNING)				
18	-	1	A,Q & L ASSY U SU	<b>Parts listed above may be found in one of the following:</b>			
19	.61896	1	A-FRAME U SU (Link Arm Style)	.61929	1	PARTS BAG ASSY (61930)	
20	.61270	1	QUADRANT SU	.61579	1	BOLT BAG (A,Q & L COMMON)	
21	.61903	1	LIFT FRAME U S (Link Arm Style)				
22	.61353	1	STAND	<b>Service Parts Kit</b>			
23	.49277	1	LIFT CHANNEL KIT U	61941K	1	UniMount <sup>®</sup> RETAINER PIN KIT	
24	.. 63208	1	3/4-10X3-3/4 HX CS G5 ZYC SPL			(Includes items 72 & 89, quantities as shown.)	
25	.. 63211	2	SPACER .758 ID X 1.0 OD X .5 LG				
26	.. 63207	1	3/4X3-1/4 HX CS G5 ZYC SPL				
27	.. 91339	2	3/4-10 PT HX JAM LK NUT NYIS ZYC				
28	.63532	2	LIGHT BRACKET TOP				
29	.63533	2	LIGHT BRACKET BOTTOM				
30	.23039	2	TRIP SPRING				
33	.61095	6	BUMPER - NO. FLX-750 1.0 DIA				
34	.63215	1	BUSHING - STOP				
35	.61287	2	BLADE GUIDE BRACKET				
36	.61487	1	SPACER .56 OD X .39 ID X .965 LG				
37	.61482	2	VINYL CAP 1/2 X 1/2				
38	.59223	4	CABLE TIE				
39	.61536	3	CABLE TIE - LONG				
42	.49033	1	REPLACEMENT GRADE 43 CHAIN ASSY				
43	.. 66439	1	3/8-16X1-1/2 HX CS G5 ZYC				
44	.. 63925	1	3/8 FLAT WASHER TY A SAE ZYC				
45	.. 91333	1	3/8-16 PT HX LK NUT NYIS ZYC				
46	.63939	2	5/16-18X1 HX FLG SCREW G5				
47	.90040	6	3/8-16X1-1/4 HX CS G5 ZYC				
48	.90043	1	3/8-16X2 HX CS G5 ZYC				
50	.90110	3	1/2-13X5 HX CS G5 ZYC				
24	.63208	1	3/4-10X3-3/4 HX CS G5 ZYC				
55	.66451	1	3/4-10X6 HX CS G5 ZYC				
61	.. 91416	2	5/8-11 HX NUT ZYC				
56	.90490K	2	5/8-11X4 EYEBOLT G2 ZYC				
45	.91333	7	3/8-16 PT HX LK NUT NYIS ZYC				
59	.91335	3	1/2-13 PT HX LK NUT NYIS ZYC				
60	.91338	1	3/4-10 PT HX LK NUT NYIS ZYC				
27	.91339	1	3/4-10 PT HX JAM LK NUT NYIS ZYC				
66	.91147	4	3/4 PLAIN WASHER TY A SAE ZYC				
67	.91911	6	5/32X 1-1/2 COTTER PIN ZYC				
70	.63585	1	STAND PIN ASSY				
72	.. 93042K	1	LINCH PIN ASSY 3/16"				
73	.. 93033K	1	PIN 1/2" X 5.5"				
80	.63586	1	LOCK PIN ASSY				
81	.. 93034K	1	STAND LOCK PIN 5/8" X 2"				
72	.. 93042K	1	LINCH PIN ASSY 3/16"				

PARTS LIST

STANDARD Steel Snowplow Diagram

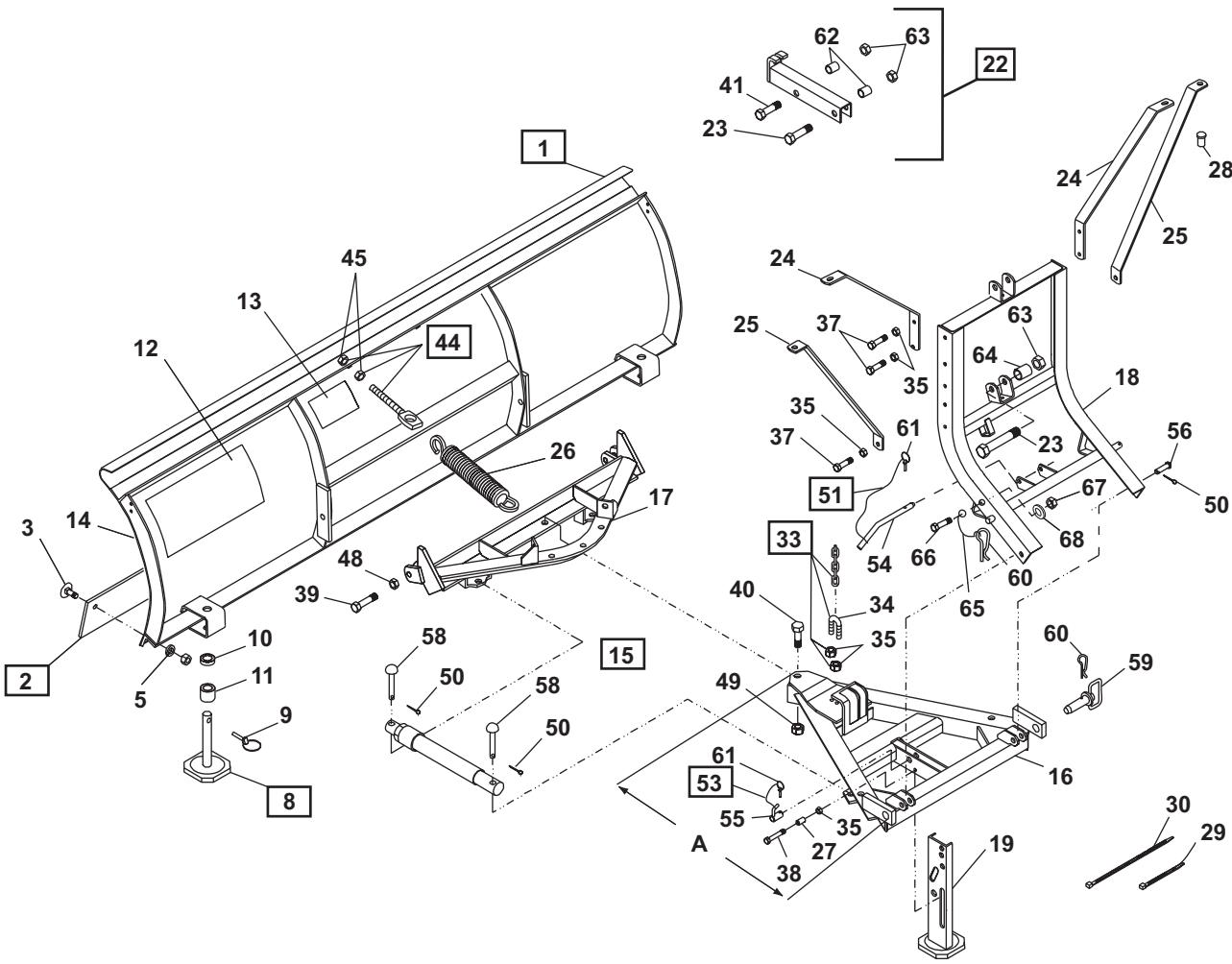



PARTS LIST

**STANDARD Steel Snowplow Parts List**

ITEM	PART NO.	QTY.	DESCRIPTION	ITEM	PART NO.	QTY.	DESCRIPTION
1	-	1	6-1/2 FT. BLADE ASSY STD	35	.91333	7	3/8-16 PT HX LK NUT NYIS ZYC
	-	1	7 FT. BLADE ASSY STD	48	.91337	2	5/8-11 PT HX LK NUT NYIS ZYC
	60018	1	7-1/2 FT. BLADE ASSY STD	49	.91338	4	3/4-10 PT HX LK NUT NYIS ZYC
2	.49066	1	CUTTING EDGE ASSY 6-1/2' S	50	.91911	6	5/32X1-1/2 COTTER PIN ZYC
	.49070	1	CUTTING EDGE ASSY 7' S	51	.63585	1	STAND PIN ASSY
	.49088	1	CUTTING EDGE ASSY 7-1/2' S	54	.93033K	1	PIN 1/2" X 5.5"
3	.90238	8	1/2-13X1-3/4 CB G8 BPO 6-1/2' 7' 7-1/2'	61	.93042K	1	LINCH PIN 3/16"
5	.91335	8	1/2-13 HX NUT NYIS ZYC 6-1/2' 7' 7-1/2'	53	.63586	1	LOCK PIN ASSY
8	.49067	2	DISC SHOE ASSY C & S	61	.93042K	1	LINCH PIN 3/16"
	.49071	2	HD DISC SHOE ASSY P TP S (Optional Service Part May Replace 49067) Includes Items No. 8, 9, 10 & 11.	55	.93034K	1	STAND LOCK PIN 5/8" X 2"
9	.93010K	1	LINCH PIN 7/16" X 1-3/4"	56	.93040	2	PIN, CLEVIS 5/8"X2.25"STEEL ZYC
10	.91109	19	WASHER - SPECIAL	58	.93063K	4	RIVET 3/4" X 3-1/2"
11	.60045	1	SPACER	59	.93028K	2	HITCH PIN 1" X 3-1/2"
12	.61740	1	LABEL - INFORMATION (Link Arm Style)	60	.91965K	4	HAIRPIN COTTER 5/32"
13	.59900	1	LABEL - INFORMATION (Warning)	61	.93042K	2	LINCH PIN 3/16" X 1-3/16"
14	.44450	1	LABEL - IDENTITY	64	.63212	1	SPACER .758 X 10 OD X .69 LG
15	-	1	A,Q & L ASSY U S	65	.63563	2	LANYARD .05 X 6
16	.61891	1	A-FRAME U S (Dim. "A" = 28-5/8") *	66	.63571	2	1/4-20 X 3/4 WLF SCREW ZYC
	.61345	1	A-FRAME U P (Dim. "A" = 31-5/8") *	67	.91331	2	1/4-20 PT HX LK NUT NYIS ZYC
17	.60036	1	QUADRANT S	68	.90311	2	1/4 FLAT WASHER
18	.61903	1	LIFT FRAME U S (Side Angle Matl. = 1/4")*	NS	28547	1	BLADE LABEL KIT, UniMount®
	.61362	1	LIFT FRAME U P (Side Angle Matl. = 3/8")*	<b>Parts listed above may be found in one of the following:</b>			
19	.61353	1	STAND	.61579	1	BOLT BAG (A, Q & L COMMON)	
22	.49277	1	LIFT CHANNEL KIT U	.61719	1	PARTS BAG ASSY (61720)	
23	.63208	1	3/4-10X4-3/4 HX CS G5 ZYC SPL	<b>Service Parts Kit</b>			
41	.63207	1	3/4-10X4-1/4 HX CS G5 ZYC SPL	61941K	1	UniMount RETAINER PIN KIT (Includes items 60 & 61, quantities as shown)	
62	.63211	2	SPACER .758 ID X 1.0 OD X .5 LG	<b>*A-frames MUST be paired with correct Lift Frame: 61891 with 61903; and 61345 with 61362.</b>			
63	.91339	2	3/4-10 PT HX JAM LK NUT NYIS ZYC	<b>Indented part numbers are included in the assembly under which they are listed. Quantities shown are included with the assembly. For a list of abbreviations, see page 5.</b>			
24	.63532	2	LIGHT BRACKET TOP SHORT				
25	.63533	2	LIGHT BRACKET BOTTOM SHORT				
26	.23039	2	TRIP SPRING				
27	.61487	1	SPACER.56 ODX.083WX.96/.97L ZYC				
28	.61482	2	VINYL CAP				
29	.59223	4	CABLE TIE				
30	.61536	3	CABLE TIE - LONG				
33	.49033	1	REPLACEMENT GRADE 43 CHAIN ASSY				
34	.90496	1	3/8-16 X 1-1/2 U-BOLT				
35	.91333	2	3/8-16 PT HX LK NUT NYIS ZYC				
37	.90040	6	3/8-16X1-1/4 HX CS G5 ZYC				
38	.90043	1	3/8-16X2 HX CS G5 ZYC				
39	.90132	2	5/8-11X3 HX CS G5 ZYC				
40	.90459	1	3/4-10X2-1/2 HX CS G5 ZYC				
23	.90159	1	3/4-10X3-1/2 HX CS G5 ZYC				
44	.90493K	2	EYEBOLT W/2—#91416 NUTS				
45	.91416	2	5/8-11 HX NUT ZYC				

PARTS LIST

STANDARD POLY PLOW Parts Diagram

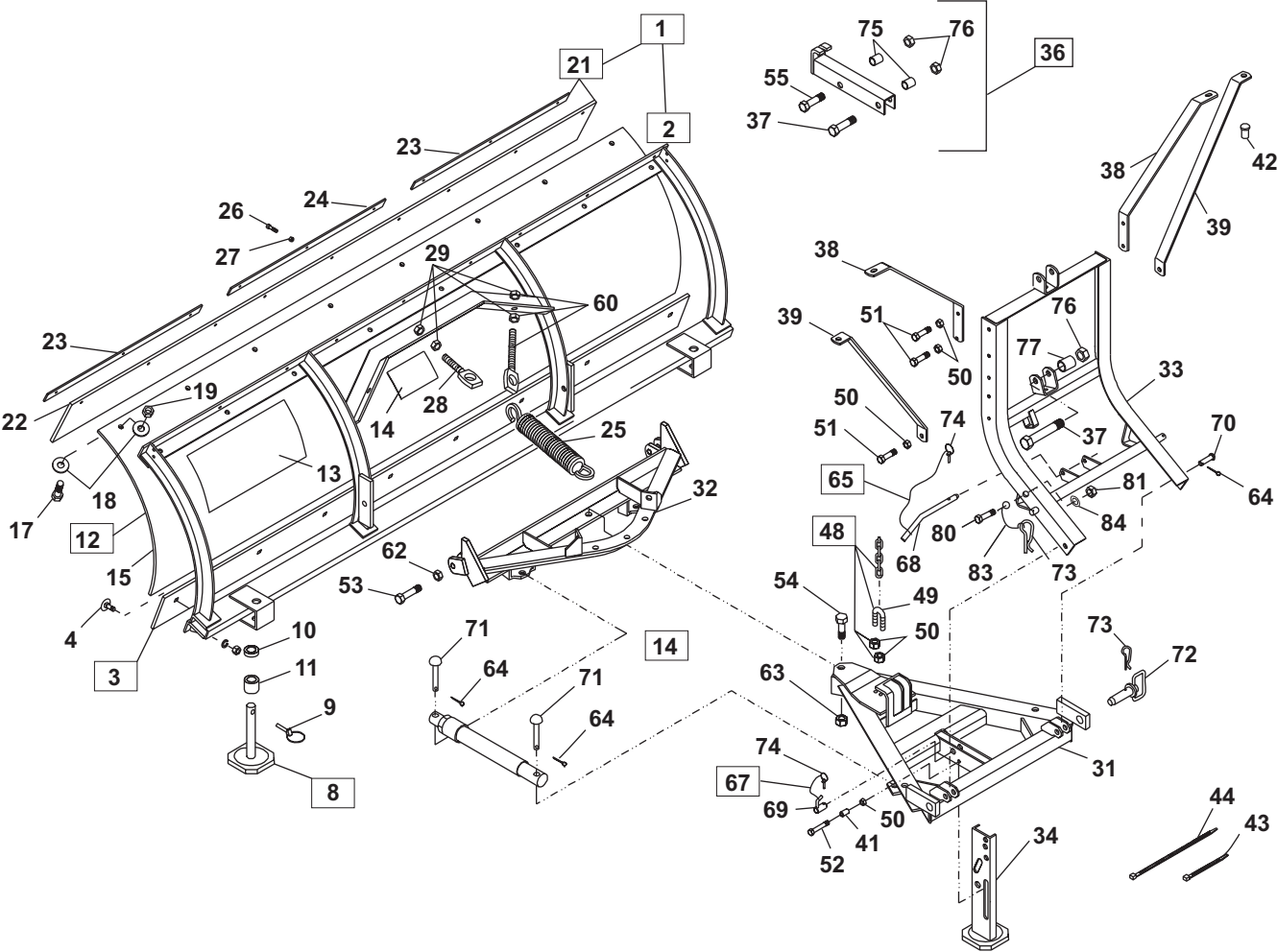

## PARTS LIST

## STANDARD POLY PLOW Parts List

ITEM	PART NO.	QTY.	DESCRIPTION	ITEM	PART NO.	QTY.	DESCRIPTION
1	-	1	7-1/2 FT. BLADE ASSY SY 62292 & 62311	53	.90132	2	5/8-11X3 HX CS G5 ZYC
2	.62292	1	7-1/2 FT BLADE S Y (W/O 62311)	54	66449	1	3/4-10X2-3/4 HX CS G5 ZP
3	..49312	1	CUTTING EDGE ASSY 7-1/2' P SY	55	66450	1	3/4-10X3 HX CS G5 ZYC
4	...90238	8	1/2-13X1-3/4 CB G8 BPO	60	90493K	2	EYEBOLT W/2-#91416 NUTS
8	..49067	2	DISC SHOE ASSY C & S (Optional Service Part - May Replace 49067)	29	91416	2	5/8-11 HX NUT ZP
	..49071	2	HD DISC SHOE ASSY P S	62	91337	2	5/8-11 PT HX LK NUT NYIS ZYC
9	...93010K	1	LINCH PIN 7/16" X 1-3/4"	63	91338	4	3/4-10 PT HX LK NUT NYIS ZYC
10	...91109	26	WASHER - SPECIAL ZYC	64	91911	6	5/32"X1-1/2" COTTER PIN ZYC
11	...60045	1	SPACER	65	.63585	1	STAND PIN ASSY
12	..49313	1	MOLDBOARD KIT 7.5' SY	68	..93033K	1	PIN 1/2" X 5"
13	...61740	1	LABEL - INFORMATION (Link Arm Style)	74	..93042K	1	LINCH PIN
14	...59900	1	LABEL - INFORMATION (Warning)	67	.63586	1	LOCK PIN ASSY
15	...56756	1	LABEL - IDENTITY	69	..93034K	1	STAND LOCK PIN 5/8"X2"
17	...90210	8	1/2-13X1-1/2 HX CS G5 ZYC	74	..93042K	1	LINCH PIN
18	...91105	16	1/2 PLAIN WASHER TY A STD ZYC	70	93040	2	PIN, CLEVIS 5/8X2.25 STEEL ZYC
19	...91335	16	1/2-13 PT HX LK NUT NYIS ZYC	71	93062	4	RIVET 3/4" X 3-1/4" G5 ZYC
20	..62111	1	BLADE FRAME - 7.5' SY	72	93028K	2	HITCH PIN 1" X 3-1/2"
21	.62311	1	7-1/2 FT SNOW DEFLECTOR ASSY	73	91965K	4	HAIRPIN COTTER 5/32"
22	..62149	1	RUBBER DEFLECTOR 7.5'	77	.63212	1	SPACER .758 ID X 1.0 OD X .69 LG
23	..64803	2	RETAINER, OUTER - 7.5'	80	.63571	2	1/4-20X3/4 WLF SCREW ZYC
24	..64802	1	RETAINER, INNER	81	.91331	2	1/4-20 HX LK NUT NYIS ZYC
25	..23039	1	TRIP SPRING	83	.63563	2	LANYARD .05"X6"
	..62312	1	BOLT BAG ASSY SY	84	.90311	2	1/4 FLAT WASHER
26	...90048	12	5/16-18X1-1/4 HX CS G5 ZYC	NS	28547	1	BLADE LABEL KIT, UniMount®
27	...91332	12	5/16-18 PT HX LK NUT NYIS ZYC	<b>Parts listed above may be found in one of the following:</b>			
28	...90490K	1	5/8-11X4 EYEBOLT G2 ZYC	61579	1	BOLT BAG (A,Q & L COMMON)	
29	...91416	2	5/8-11 HX NUT ZYC	62066	1	PARTS BAG ASSY (62120)	
30	-	1	A,Q & L ASSY U SY	<b>Service Parts Kit</b>			
31	.61891	1	A-FRAME US *	61941K	1	UniMount RETAINER PIN KIT Includes items 73 (4) & 74 (2)	
32	.62101	1	QUADRANT SY	<b>* A-frame MUST be paired with correct lift frame, 61891 with 61903.</b>			
33	.61903	1	LIFT FRAME U S *	<b>For a list of abbreviations, see page 5.</b>			
34	.61353	1	STAND				
36	.49277	1	LIFT CHANNEL KIT U				
55	..63207	1	3/4-103-1/4 HX CS G5 ZYC SPL				
37	..63208	1	3/4-10X3-3/4 HX CS G5 ZYC SPL				
75	..63211	2	SPACER .758 ID X 1.0 OD X .5 LG				
76	..91339	2	3/4-10 PT HX JAM LK NUT NYIS ZYC				
37	.63208	1	3/4-10X3-3/4 HX CS G5 ZYC SPL				
38	.63532	2	LIGHT BRACKET TOP SHORT				
39	.63533	2	LIGHT BRACKET BOTTOM SHORT				
24	.23039	2	TRIP SPRING				
41	.61487	1	SPACER .56 OD X.39 ID X.965 LG				
42	.61482	2	VINYL CAP 1/2 x 1/2				
43	.59223	4	CABLE TIE				
44	.61536	3	CABLE TIE - LONG				
48	.49033	1	REPLACEMENT GRADE 43 CHAIN ASSY				
49	..90496	1	3/8-16 X 1 1/2 U-BOLT ZYC				
50	..91333	2	3/8-16 PT HX LK NUT NYIS ZYC				
	..91333	7	3/8-16 PT HX LK NUT NYIS ZYC				
51	.90040	6	3/8-16X1-1/4 HX CS G5 ZYC				
52	.90043	1	3/8-16X2 HX CS G5 ZYC				

PARTS LIST

POLY PRO-PLOW® Parts Diagram and List

(See Page 14 for POLY PRO-PLOW Blade A, Q & L Diagram and Parts List)

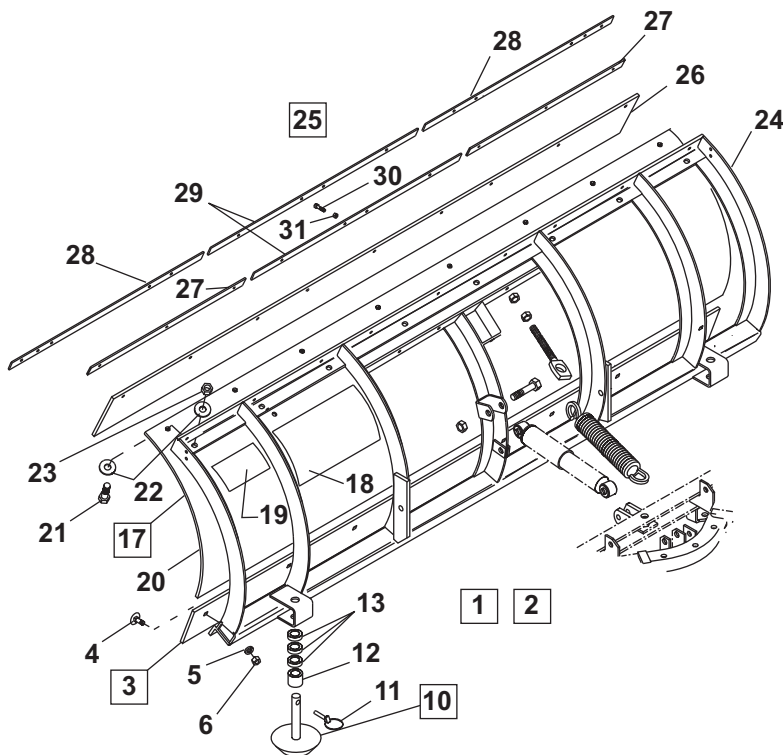

ITEM	PART NO.	QTY.	DESCRIPTION
1	62400	1	7.5 FT BLADE PY 62395 & 62396
	62450	1	8.0' BLADE PY 62420 & 62402
2	. 62395	1	7-1/2 FT BLADE PY(W/O 62396)
	. 62420	1	8.0' BLADE ASSEMBLY PY (W/O 62402)
3	.. 49312	1	CUTTING EDGE ASSY 7-1/2' S PY
	.. 49328	1	CUTTING EDGE ASSY 8.0' PY
4	... 90238	8	1/2-13X1-3/4 CB G8 BPO
5	... 91205	8	1/2 SP LK WASHER ZYC
6	... 90337	8	1/2-13 HX NUT ZYC
10	.. 49071	2	HD DISC SHOE ASSY P
11	... 93010K	1	LINCHPIN 7/16" X 1-3/4"
12	... 60045	1	SPACER
13	... 91109	26	WASHER - SPECIAL ZYC
17	.. 49322	1	MOLDBOARD ASSY 7.5' PY
	.. 49327	1	MOLDBOARD ASSY 8.0' PY
18	... 61740	1	LABEL - INFORMATION (Link Arm Style)
19	... 59900	1	LABEL - INFORMATION (WARNING)
20	... 44450	1	LABEL - IDENTITY

ITEM	PART NO.	QTY.	DESCRIPTION
21	... 90100	8	1/2-13X1-1/2 HX CS G5 ZYC
22	... 91105	16	1/2 PLAIN WASHER TY A STD ZYC
23	... 91335	8	1/2-13 PT HX LK NUT NYIS ZYC
24	.. 62350	1	BLADE FRAME - 7.5' PY
	.. 62415	1	BLADE FRAME - 8.0' PY
25	. 62396	1	7-1/2 FT SNOW DEFLECTOR ASSY
	. 62402	1	8 FT SNOW DEFLECTOR ASSY PY
26	.. 62149	1	RUBBER DEFLECTOR 7.5'
	.. 62394	1	RUBBER DEFLECTOR 8.0'
27	.. 64803	2	RETAINER, OUTER - 7.5'
28	.. 64801	2	RETAINER, OUTER - 9.0'
29	.. 64802	1	RETAINER, INNER
30	... 90021	12	5/16-18X1-1/4 HX CS G5 ZYC
31	... 91332	12	5/16-18 PT HX LK NUT NYIS ZYC
NS	28547	1	BLADE LABEL KIT, UniMount®

Parts listed above may be found in following:  
62397 1 BOLT BAG ASSY (62396 & 62381)

\*\* 3 for the 7-1/2 ft blade and 2 for the 8 ft blade.

For a list of abbreviations, see page 5.

PARTS LIST

**Steel PRO-PLOW® Parts Diagram and List**

(See Page 14 for Steel PRO-PLOW Blade A, Q & L Diagram and Parts List)

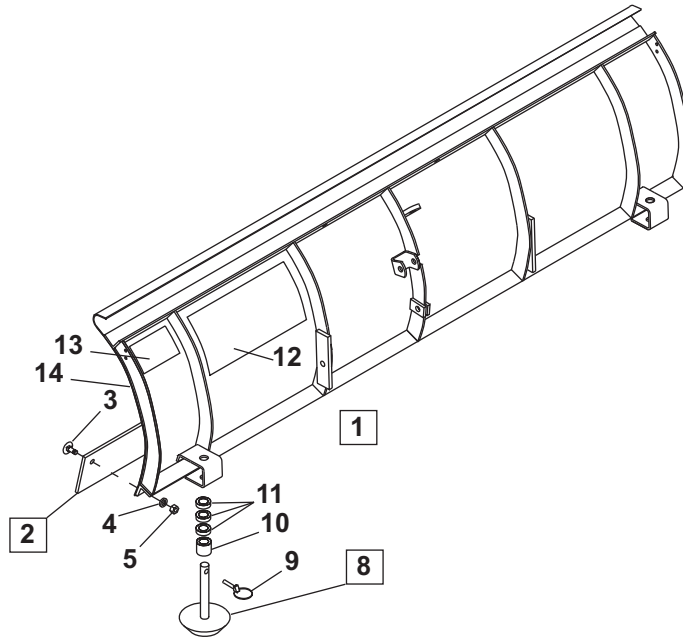

ITEM	PART NO.	QTY.	DESCRIPTION	ITEM	PART NO.	QTY.	DESCRIPTION
1	60381	1	7-1/2 FT BLADE ASSY P	8	. 49071	2	HD DISC SHOE ASSY P
	60390	1	8 FT BLADE ASSY P	9	. . 93010K	1	LINCHPIN 7/16" X 1-3/4"
	60308	1	8-1/2 FT BLADE ASSY PY	10	. . 60045	1	SPACER
	-	1	9 FT BLADE ASSY P	11	. . 91109	19	WASHER - SPECIAL ZYC
2	. 49088	1	CUTTING EDGE ASSY 7-1/2' P	12	. 61740	1	LABEL - INFORMATION (Link Arm Style)
	. 49089	1	CUTTING EDGE ASSY 8' P	13	. 59900	1	LABEL - INFORMATION (WARNING)
	. 49086	1	CUTTING EDGE ASSY 8-1/2' P	14	. 44450	1	LABEL - IDENTITY
	. 49251	1	CUTTING EDGE ASSY 9' P	NS	28547	1	BLADE LABEL KIT, UniMount®
3	. . 90238	*	1/2-13X1-3/4 CB G8 BPO				
4	. . 91205	*	1/2 SP LK WASHER ZYC				
5	. . 91415	*	1/2-13 HX NUT ZYC				

\* 8 each except for 9 ft blade — 10 each.

Indented parts are included in the assembly under which they are listed. Quantities shown are included with the assembly.

**For a list of abbreviations, see page 5.**

PARTS LIST

**A, Q & L (Steel PRO-PLOW® and POLY PRO-PLOW® Blades) Diagram and Parts List**

(See Page 12 for POLY PRO-PLOW Blade Diagram and Parts List)

(See Page 13 for Steel PRO-PLOW Blade Diagram and Parts List)

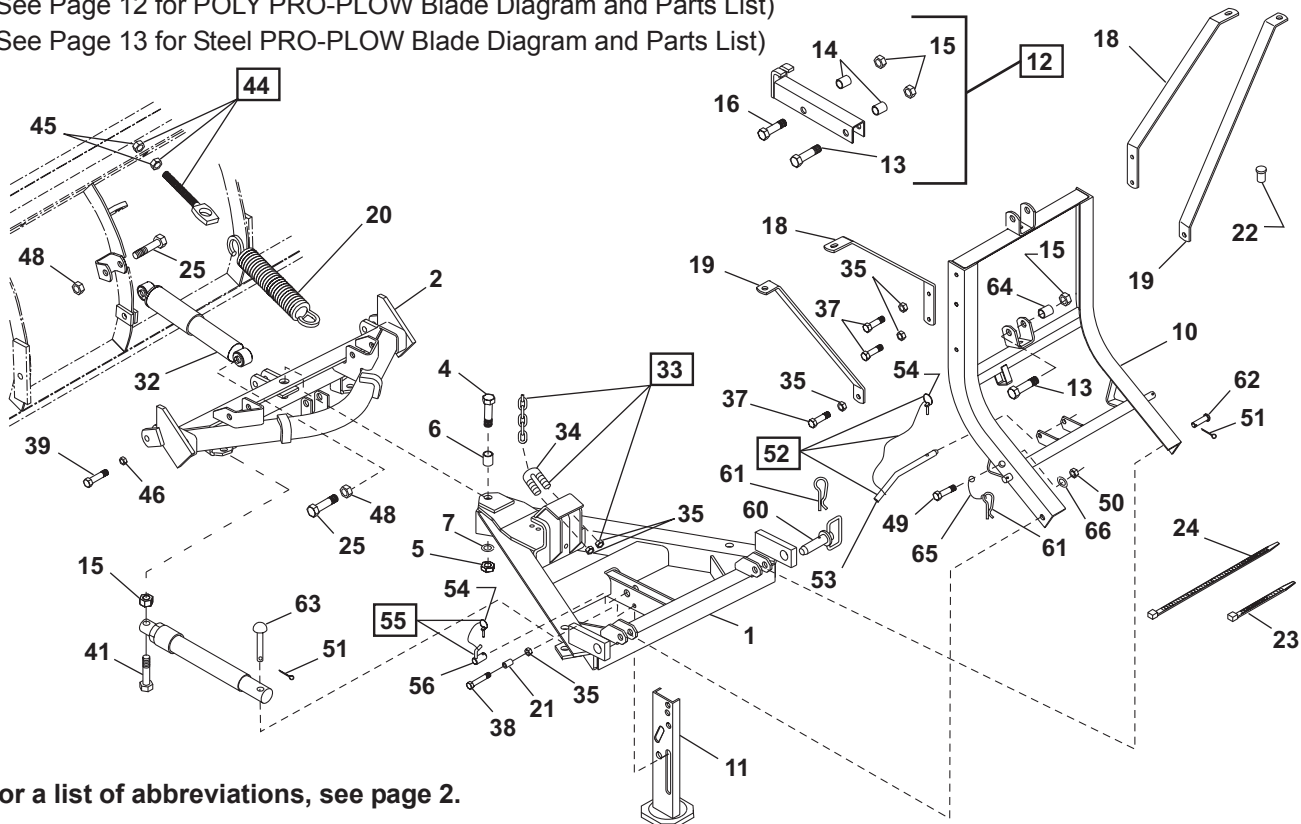

For a list of abbreviations, see page 2.

ITEM	PART NO.	QTY.	DESCRIPTION	ITEM	PART NO.	QTY.	DESCRIPTION
1	63581	1	A-FRAME U P	39	90132	3	5/8-11X3 HX CS G5 ZYC
2	63582	1	QUADRANT P	41	90161	2	3/4-10X4 HX CS G5 ZYC
4	.63573	1	3/4-10X4 HX FLG CS G8 ZYC	44	90493K	4	EYEBOLT W/2-#91416 NUTS
5	.63574	1	3/4-10 PT HX FLG LK NUT ZYC	45	.91416	2	5/8-11 HX NUT ZYC
6	.63492	1	TUBE SPACER (1.06 LG)	46	91337	3	5/8-11 PT HX LK NUT NYIS ZYC
7	.63575	1	3/4 SAE STRUCTURAL WASHER	48	91339	2	3/4-10 PT HX JAM LK NUT NYIS ZYC
10	61362	1	LIFT FRAME U P	49	63571	2	1/4-20X1-3/4 WLF SCREW ZYC
11	61353	1	STAND	50	91331	2	1/4-20 PT HX LK NUT NYIS ZYC
12	49277	1	LIFT CHANNEL KIT U	51	91911	4	5/32X1-1/2 COTTER PIN ZYC
13	.63208	1	3/4-10X3-3/4 HX CS G5 ZYC	52	63585	1	STAND PIN ASSY
	63208	1	3/4-10X3-3/4 HX CS G5 ZYC	53	.93033K	1	PIN 1/2" X 5.5"
14	.63211	2	SPACER .758 ID X 1.0 OD X .5 LG	54	.93042K	1	LINCH PIN 3/16"
15	.91338	2	3/4-10 PT HX LK NUT NYIS ZYC	55	63586	1	LOCK PIN ASSY
	91338	3	3/4-10 PT HX LK NUT NYIS ZYC	54	.93042K	1	LINCH PIN 3/16"
16	.63207	1	3/4-10X3-1/4 HX CS G5 ZYC	56	.93034K	1	STAND LOCK PIN 5/8" X 2"
18	63532	2	LIGHT BRACKET TOP SHORT	60	93028K	2	HITCH PIN 1" X 3-1/2"
19	63533	2	LIGHT BRACKET BOTTOM SHORT	61	91965K	4	HAIRPIN COTTER 5/32"
20	23039	4	TRIP SPRING	62	93040	2	PIN CLEVIS 5/8X2.25 STEEL ZYC
21	61487	1	SPACER .56 OD X .39 ID X .965 LG	63	93063K	2	RIVET 3/4" X 3-1/4"
22	61482	2	VINYL CAP 1/2 X 1/2	64	63212	1	SPACER .758 ID X 1.0 OD X .69 LG
23	59223	4	CABLE TIE	65	63563	2	LANYARD .05 X 6
24	61536	3	CABLE TIE -LONG	66	90311	2	1/4 FLAT WASHER
25	90157	2	3/4-10X3 HX CS G5 ZYC	<b>Parts listed above may be found in one of the following:</b>			
32	60338	1	SHOCK ABSORBER ASSEMBLY	63569	1	PARTS BAG ASSY (63568)	
33	49033	1	REPLACEMENT GRADE 43 CHAIN ASSY	61579	1	BOLT BAG (A,Q&L COMMON)	
34	.90496	1	3/8-16X1-1/2 U-BOLT ZYC	<b>Service Parts Kit</b>			
35	.91333	2	3/8-16 PT HX LK NUT NYIS ZYC	61941K	1	UniMount® RETAINER PIN KIT	
	91333	8	3/8-16 PT HX LK NUT NYIS ZYC	(Includes items 54 and 61, quantities as shown.)			
37	90040	6	3/8-16X1-1/4 HX CS G5 ZYC				
38	90043	1	3/8-16X2 HX CS G5 ZYC				

Indented parts are included in the assembly under which they are listed. Quantities shown are included with the assembly.

**PARTS LIST**

---

This page intentionally left blank.

PARTS LIST

HEAVYWEIGHT Snowplow Parts Diagram

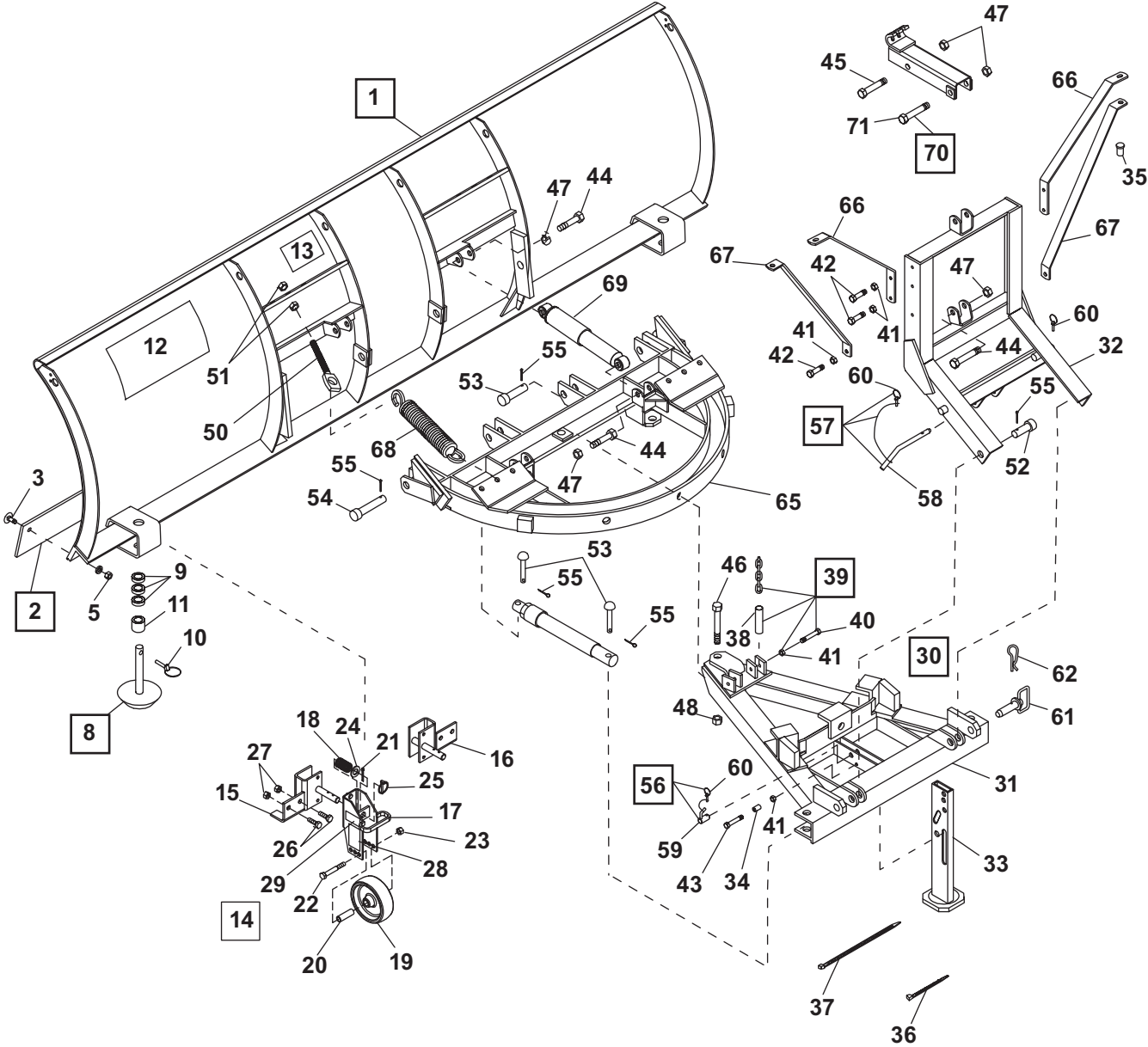



PARTS LIST

HEAVYWEIGHT Snowplow Parts List

ITEM	PART NO.	QTY.	DESCRIPTION	ITEM	PART NO.	QTY.	DESCRIPTION
	62301	1	9' BLADE ASSY 62890 & 62425	39	49263	1	REPLACEMENT GRADE 43 HIGH TEST CHAIN ASSY UHW HW
	62302	1	10' BLADE ASSY 62891 & 62425	40	90063	2	3/8-16X3 HX CS G8 ZYC
1	62890	1	9' BLADE ASSY UHW	41	91333	2	3/8-16 PT HX LK NUT NYIS ZYC
	62891	1	10' BLADE ASSY UHW		91333	7	3/8-16 PT HX LK NUT NYIS ZYC
2	58817	1	CUTTING EDGE ASSY 9' UHW HW	42	90040	6	3/8-16X1-1/4 HX CS G5 ZYC
	58818	1	CUTTING EDGE ASSY 10' UHW HW	43	90043	1	3/8-16X2 HX CS G5 ZYC
	.43240	1	BOLT BAG 12 PIECE	44	90159	5	3/4-10X3-1/2 HX CS G5 ZYC
3	-	12	5/8-11X2-1/2 CARRIAGE BOLT G5	45	90161	1	3/4-10X4 HX CS G5 ZYC
5	-	12	5/8-11 HX LK NUT GB	46	90176	1	1-8X4 HX CS G2 ZYC
8	49071	2	HD DISC SHOE ASSY P TP S	47	91338	7	3/4-10 PT HX LK NUT NYIS ZYC
9	91109	52	WASHER - SPECIAL ZYC	48	91340	1	1-8 PT HX LK NUT NYIS ZYC
10	93010K	2	LINCH PIN 7/16" X 1-3/4"	50	90493K	6	EYEBOLT W/2-#91416 NUTS
11	60045	2	SPACER	51	91416	2	5/8-11 HX NUT ZYC
12	61740	1	LABEL INFORMATION (Link Arm Style)	52	93072	2	1 X 2-5/16 RIVET G5 ZYC
13	59900	1	LABEL INFORMATION (WARNING)	53	93077K	6	RIVET 1" X 4"
				54	93080	2	1X5 RIVET G5 ZYC
14	62425	1	DOLLY WHEEL ASSY, P PY HW	55	91911	10	5/32 X 1-1/2 COTTER PIN ZYC
15	62432	1	SUPPORT DR, P PY HW	56	63586	1	STAND LOCK PIN ASSY
16	62433	1	SUPPORT CU, P PY HW	59	93034K	1	STAND LOCK PIN
17	62429	2	YOKE	60	93042K	1	LINCH PIN 3/16"
18	62423	2	SPRING 1-1/8 X 2	57	63585	1	STAND PIN ASSY
19	62421	2	WHEEL 6X2	58	93033K	1	PIN 1/2" X 5.5"
20	62424	2	SPACER	60	93042K	4	LINCH PIN 3/16"
21	91911	2	5/32X1-1/2 COTTER PIN ZYC	60	93042K	2	LINCH PIN 3/16"
22	90610	2	1/2-13X3-1/2 HX CS G5 ZYC	61	93028K	2	HITCH PIN 1" X 3-1/2"
23	91335	2	1/2-13 PT HX LK NUT NYIS ZYC	62	91965K	2	HAIRPIN COTTER 5/32"
24	91147	2	3/4 PLAIN WASHER TY A SAE ZYC		-	1	A, Q & L ASSY UHW (BOX 2 OF 2)
25	93042	2	3/16 LINCHPIN ZYC	65	62190	1	QUADRANT UHW
26	90100	4	1/2-13PX1-1/2 HX CS G5 ZYC	66	61552	2	LIGHT BRACKET TOP U
27	91335	4	1/2-13 PT HX LK NUT NYIS ZYC	67	61553	2	LIGHT BRACKET BOTTOM U
28	62437	2	LABEL - INFORMATION (INSTRUCTIONS)	68	23039	6	TRIP SPRING
				69	60338	2	SHOCK ABSORBER ASSEMBLY
29	62447	4	LABEL - INFORMATION	70	62154	1	LIFT CHANNEL KIT UHW
30	62300-1	1	A, Q & L ASSY UHW (62298 & 62299)	71	90160	1	3/4-10X4-1/2 HX CS G5 ZYC
	-	1	A, Q & L ASSY UHW (BOX 1 OF 2)				
31	62170	1	A-FRAME UHW				
32	62185	1	LIFT FRAME UHW				
33	62199	1	STAND UHW				
34	61487	1	SPACER .56 OD X .39 ID X .965 LG				
35	61482	2	VINYL CAP 1/2 X 1/2				
36	59223	5	CABLE TIE				
37	61536	3	CABLE TIE - LONG				
38	65508	1	PLASTIC TUBE				

Parts listed above may be found in the following:

62282 1 PARTS BAG ASSY (62300)

Service Parts Kit

61941K 1 UniMount® RETAINER PINKIT  
(Includes 4 each of item 62 and 2 each of item 60)

\*\* Cutting Edge Assembly Fasteners:  
For 9' - 11 each, For 10' - 12 each.

Indented parts are included in the assembly under which they are listed.  
Quantities shown are included with the assembly.

For a list of abbreviations, see page 5.

PARTS LIST

Solenoid ISARMATIC® Mark IIIA Parts Diagram

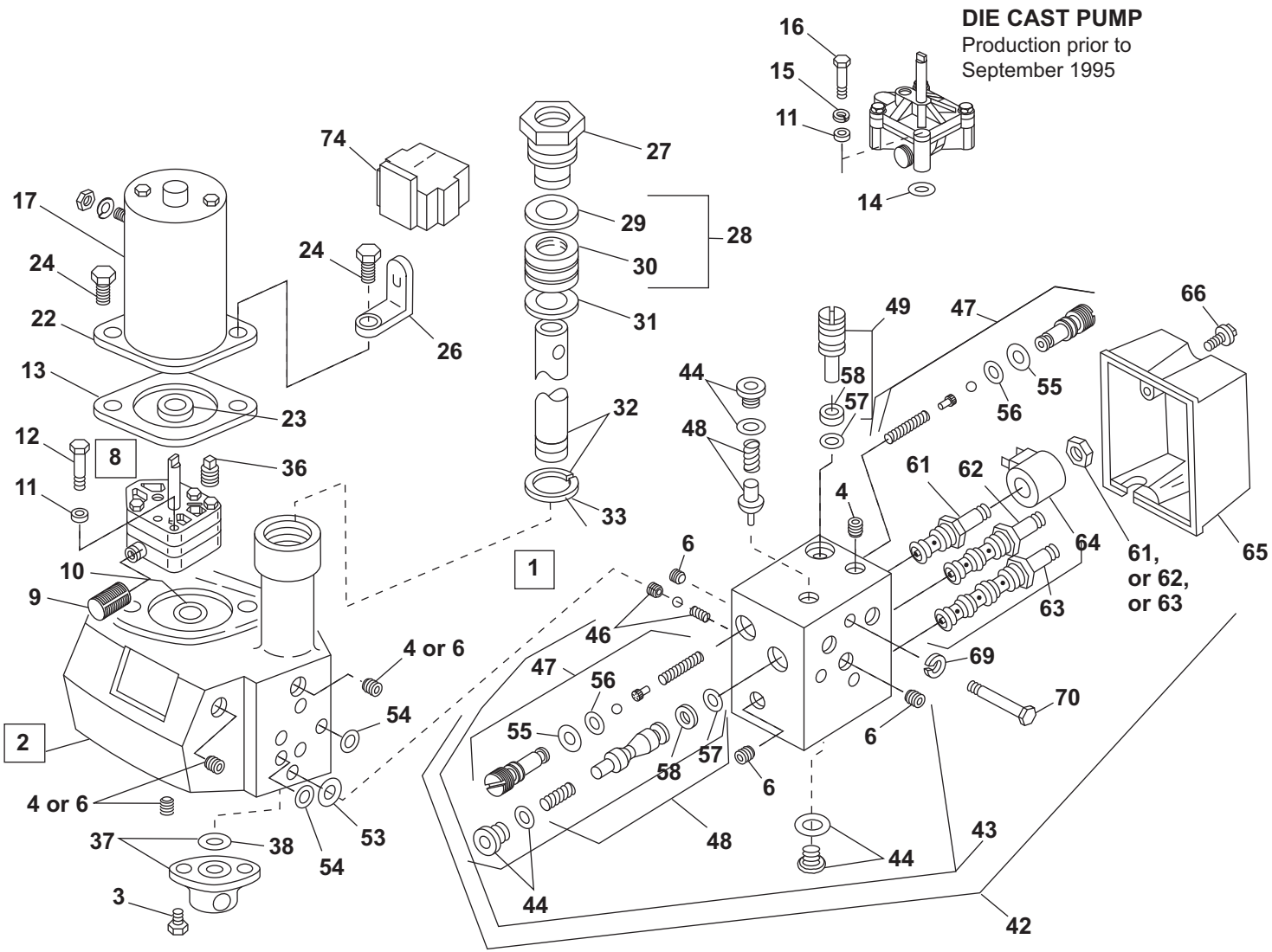

PARTS LIST

Solenoid ISARMATIC® Mark IIIA Parts List

ITEM	PART NO.	QTY.	DESCRIPTION	ITEM	PART NO.	QTY.	DESCRIPTION
1	49253	1	HYDRAULIC UNIT 1-1/2" SOL 3500	*48	49226	1	POPPET CHECK VALVE KIT
	49280	1	HYDRAULIC UNIT 1-1/2" SOL 2500	*49	56330	1	QUILL ASSY
2	49252	1	SERVICE HOUSING KIT 1-1/2" SOL		56657	1	O-RING & BACK-UP RING KIT
3	93166	2	5/16-18X1-1/4 HXW TRTS TY TR-3	*53	56274	1	O-RING - 013 } NOT INCLUDED
4	92095	3	PLUG 1/4 NPTF HX SO	*54	25730	2	O-RING - 012 } W/ 49265 or 49224
			THREAD SEAL	*55	25731	2	O-RING - 010
6	92071	2	PLUG 1/8 NPTF HX SO STEEL	*56	55371	2	O-RING - 008
			(W/O Fluid Level Plug)	*57	25622	2	O-RING - 006
8	49211	1	HYDRAULIC PUMP KIT	*58	56315	2	BACK UP RING - 006 PARBAK SPLIT
9	56185	1	SUCTION FILTER	61	49227K	1	CARTRIDGE 20 W/JAM NUT
10	56416	1	O-RING - 014	*	49258-1	1	SEAL KIT - CARTRIDGES 20
11	90311	2	1/4 FLAT WASHER TY A STD ZYC	62	49228	1	CARTRIDGE 30 W/JAM NUT
12	90080	2	5/16-18X2-1/2 HX CS G5 ZYC	63	49229	1	CARTRIDGE 40 W/JAM NUT
*13	25861	1	GASKET	*	49259-1	2	SEAL - KIT CARTRIDGE 30, 33 & 40
<b>The following three parts are used only for Die Cast Pumps</b>				64	49230K	3	COIL W/SPADE TERMINALS
*14	25620	1	O-RING - 115	65	56291	1	COVER ASSY
15	91220	2	BELLEVILLE SPRING WASHER	66	90650	2	#8-32X1/2 TORX TCTS TY D ZYC
16	90025	2	5/16-18X2-1/4 HX CS G5 ZYC	69	91201	3	1/4 SP LK WASHER ZYC
				70	90083	3	1/4-20X3-1/4 HX CS G5 ZYC
				74	61246	1	CABLE BOOT
17	56133	1	MOTOR ASSY 4-1/2"	**	21294	1	PLOW CABLE ASSY
			(See next page for motor service parts.)	76	49340	1	MAJOR OVERHAUL KIT 1-1/2" SOL
22	49084	1	MOTOR FLANGE BRG & SEAL	* Items included in Major Overhaul Kit No. 49340			
*23	49014	1	OIL SEAL	** Not Shown			
24	90066	2	7/16-14X1-1/4 HX CS G5 ZYC	Indented parts are included in the assembly under which they are listed.			
26	56356	1	BOOT BRACKET KIT	Quantities shown are included with the assembly.			
27	25944K	1	PACKING NUT 1-1/2"	<b>For a list of abbreviations, see page 5.</b>			
28	25205K	1	PACKING SET W/WIPER 1-1/2"				
*29	55137	1	WIPER RING - 1-1/2"				
*30	55136	1	PACKING SET 1-1/2"				
31	338	1	FLAT WASHER - SPECIAL				
32	25202	1	PLUNGER KIT 1-1/2 X 6				
			(Lift Ram Application Only)				
33	48414	3	SPIRAL RETAINER RING 1-1/2"				
36	92079	1	PLUG 3/8 NPTF SQ				
37	25968K	1	BASE LUG W/#25618 O-RING				
*38	25618	1	O-RING - 216				
42	49265	1	VALVE MANIFOLD ASSY SOL 3500				
43	49224	1	MANIFOLD ASSY SOL 3500				
			(W/O cartridges)				
42	49278	1	VALVE MANIFOLD ASSY SOL 2500				
43	49279	1	MANIFOLD ASSY SOL 2500				
44	92960	3	3/8-24 HX SO O-RING BOSS PLUG				
6	92071	3	PLUG 1/8 NPTF HX SO STEEL				
4	92095	1	PLUG 1/4 NPTF HX SO THREAD SEAL				
46	49225	1	INLET CHECK VALVE KIT				
47	49138K	1	RELIEF VALVE KIT-2 SETS				

PARTS LIST

**Motor Manufacturer Identification and Service Parts**

Photos show terminal positions and end caps for brand identification.



PART NO.	QTY.	DESCRIPTION
56620	1	BRUSH KIT - BOSCH 2 TERMINAL
21508	2	CS HX 1/4-20 X 6-1/4 G5 ZYC
91201	2	WASHER SP LK 1/4
21535	1	WASHER, FIBER THRUST 5/8 (drive end)



PART NO.	QTY.	DESCRIPTION
56638	1	END CAP W/ O-RING – PRESTOLITE 2 TERMINAL
56621	1	THRU-BOLT KIT – PRESTOLITE 2 TERMINAL (Includes cap screws and special washers.)
56641	1	THRUST WASHER KIT – PRESTOLITE 2 TERMINAL (Includes retaining ring for early production.)



PART NO.	QTY.	DESCRIPTION
56637	1	END CAP W/ O-RING – BOSCH BIC
56639	1	BRUSH KIT – BOSCH BIC
56640	1	THRU-BOLT KIT – BOSCH BIC (Includes special cap screws, washers and O-rings.)
21535	1	WASHER FIBER THRUST 5/8 (drive end)



PART NO.	QTY.	DESCRIPTION
21548	1	BRUSH KIT – BOSCH 1 TERMINAL
21508	2	CS HX 1/4-20 X 6-1/4 G5 ZYC
91201	2	WASHER SP LK 1/4
21535	1	WASHER, FIBER THRUST 5/8 (drive end)
56397	1	BOLT BAG ASSY GROUND HARDWARE

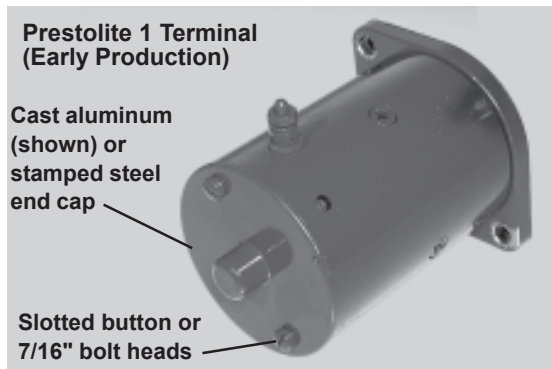

PART NO.	QTY.	DESCRIPTION
49262	1	BRUSH KIT – PRESTOLITE 1 TERMINAL
56397	1	BOLT BAG ASSY GROUND HARDWARE

For a list of abbreviations, see page 5.

**PARTS LIST**

---

This page intentionally left blank.

PARTS LIST

Snowplow Headlamps and Hydra-Turn® Parts Diagram

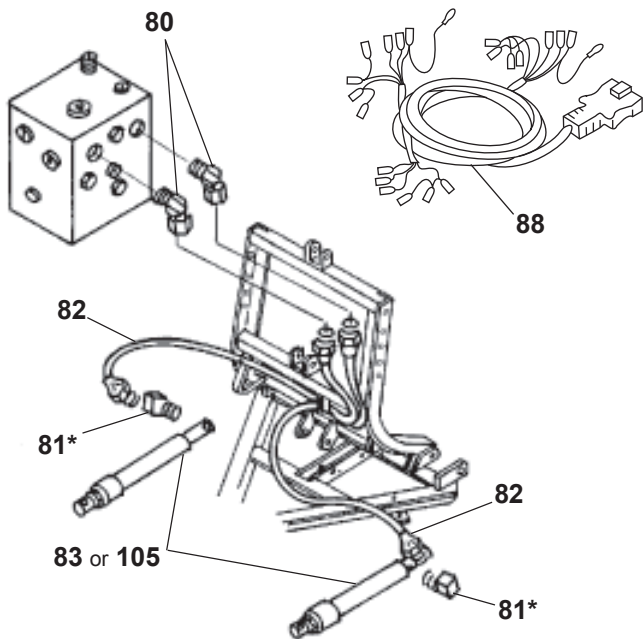
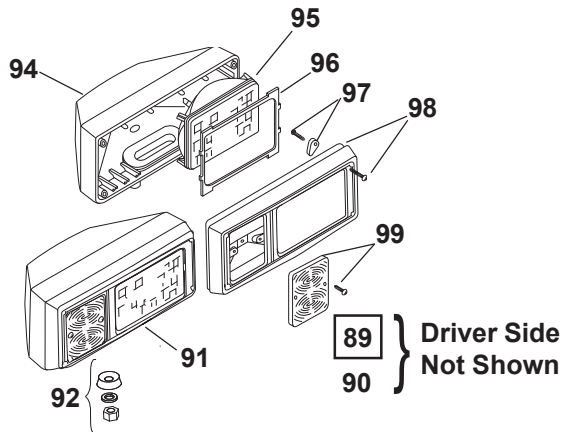

SAE O-Ring Port/Gland Nut Ram Assembly

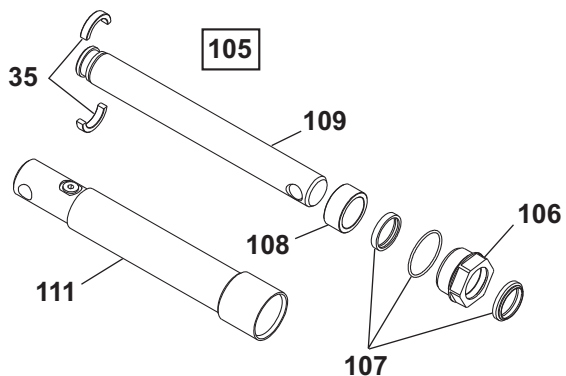

NPTF Port/Packing Nut Ram Assemblies

Rectangular Shaped Split Bearing Ram Assembly

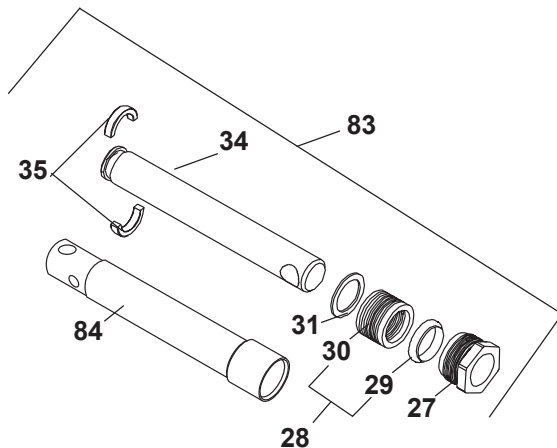

Retainer Ring Ram Assembly  
(Not available in complete assembly.)

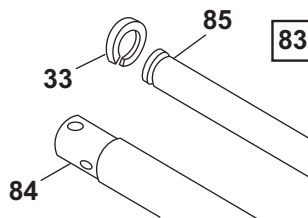

"L" Shaped Split Bearing Ram Assembly  
(Not available in complete assembly.)

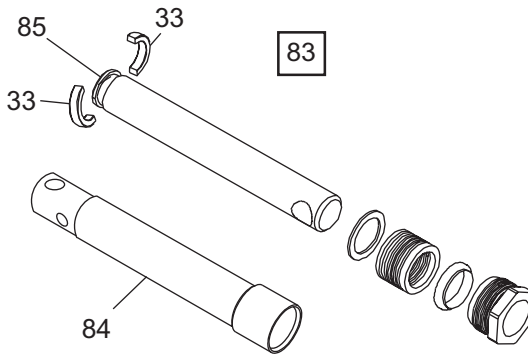

PARTS LIST

Snowplow Headlamps and Hydra-Turn® Parts List

NPTF Port/Packing Nut Ram Assy

ITEM	PART NO.	QTY.	DESCRIPTION
80	92190K	2	SWIVEL HOSE FITTING 1/4" X 45°
81	92210K	2	STREET ELBOW 1/4" X 90°
82	55020K	2	PRESSURE HOSE 1/4" x 38"
83	62540	2	RAM ASSY 1-1/2" X 6" (Rectangular Split Bearing)
	62550K	2	RAM ASSY 1-1/2" X 10" (Rectangular Split Bearing)
	25878K	2	RAM ASSY 2" X 16" (Retainer Ring)
	62540		RAM ASSY 1-1/2" X 6" (Retainer Ring)
	62550K		RAM ASSY KIT 1-1/2" X 10" (Retainer Ring)
27	.25944K	1	PACKING NUT 1-1/2"
	.25948	1	PACK NUT 2"
28	.25205K	1	PACKING SET W/WIPER 1-1/2"
	.25215	1	PACKING SET W/WIPER 2"
29	.55137	1	WIPER RING 1-1/2"
	.55210	1	WIPER RING 2"
30	.55136	1	PACKING SET 1-1/2"
	.55209	1	PACKING SET 2"
31	.91167	1	WASHER – SPECIAL (1-1/2")
	.91174	2	WASHER – SPECIAL (2")
85	.62545	1	PLUNGER 1-1/2" X 6" (Split Bearing)
	.56584	1	PLUNGER 1-1/2" X 10" (Split Bearing)
	.25202	1	USE-62540 RAM ASSY 1-1/2 X 6 (Retainer Ring & L-Shaped Split Bearing) (Angling Ram Application Only)
	.56105	1	USE-62550 RAM ASSY 1-1/2 X 10 (Retainer Ring & L-Shaped Split Bearing)
	.25703	1	PLUNGER KIT 2" X 16" (Retainer Ring)
33	.48414	3	SPIRAL RETAINER RING 1-1/2" (Used in Place of L-Shaped Split Bearing)
	.48413	1	SPIRAL RETAINER RING KIT
34	.56584	1	PLUNGER 1-1/2" X 10" (Rectangular Split Bearing)
84		1	CYLINDER 1-1/2" X 6"
		1	CYLINDER 1-1/2" X 10" (Rectangular Split Bearing)
	.25949	1	CYLINDER 2" X 16" (Retainer Ring)
	.62540	1	RAM ASSY 1-1/2" X 6" (Retainer Ring & L-Shaped Split Bearing)
	.62550K	1	RAM ASSY KIT 1-1/2" X 10" (Retainer Ring & L-Shaped Split Bearing)

SAE O-Ring Port/Gland Nut Ram Assy

ITEM	PART NO.	QTY.	DESCRIPTION
81	56539K	2	ELBOW, 90F –6 O-RING/1/4" NPTF (for LSX)
105	56538K	2	RAM ASSY 1-1/2" X 8"
106	.56555	1	GLAND NUT POLYPAK SEAL
107	.56556	1	SEAL KIT W/POLYPAK SEAL
108	.56537	1	SPACER
109	.56534	1	PLUNGER 1-1/2" X 8" (Split Bearing)
35	.62290	2	SPLIT BEARING 1-1/2"
111	.56536	1	CYLINDER 1-1/2" X 8" (Rectangular Split Bearing O-Ring Port)

Plow Headlamps

ITEM	PART NO.	QTY.	DESCRIPTION
88	62503	1	PLOW HARNESS KIT 7-PIN
	61438	1	PLOW HARNESS KIT 9-PIN
	61558	1	PLOW HARNESS KIT 12-PIN
89	61543	1	HEADLAMP PAIR (W/O Plow Harness)
90	.61541	1	HEADLAMP DR
91	.61542	1	HEADLAMP CU
92	.49151	1	SWIVEL AND HARDWARE ASSY
94	.49298	1	HEADLAMP HOUSING ASSY (Fits DR or CU)
95	.49297	1	REPLACEMENT SEALED BEAM (2E1)
96	.49210	1	HEADLAMP GASKETS (1 pair)
97	.49201	1	RETAINER FINGER & FASTENER (4 EA)
98	.49203	1	BEZEL W/FASTENERS (DR or CU)
99	.49202	1	PARK/TURN LENS 2/FASTENERS
**	.49362	1	PARK/TURN REPLACEMENT SOCKETS
**		4	PARK/TURN SIGNAL BULB (Trade Number 1157)

\*\* Not Shown

**NOTE:** Only those items listed with a **PART NUMBER** are available for service.

Indented parts are included in the assembly under which they are listed. Quantities shown are included with the assembly.

**For a list of abbreviations, see page 5.**

# PARTS LIST

## Vehicle Components Parts Diagram

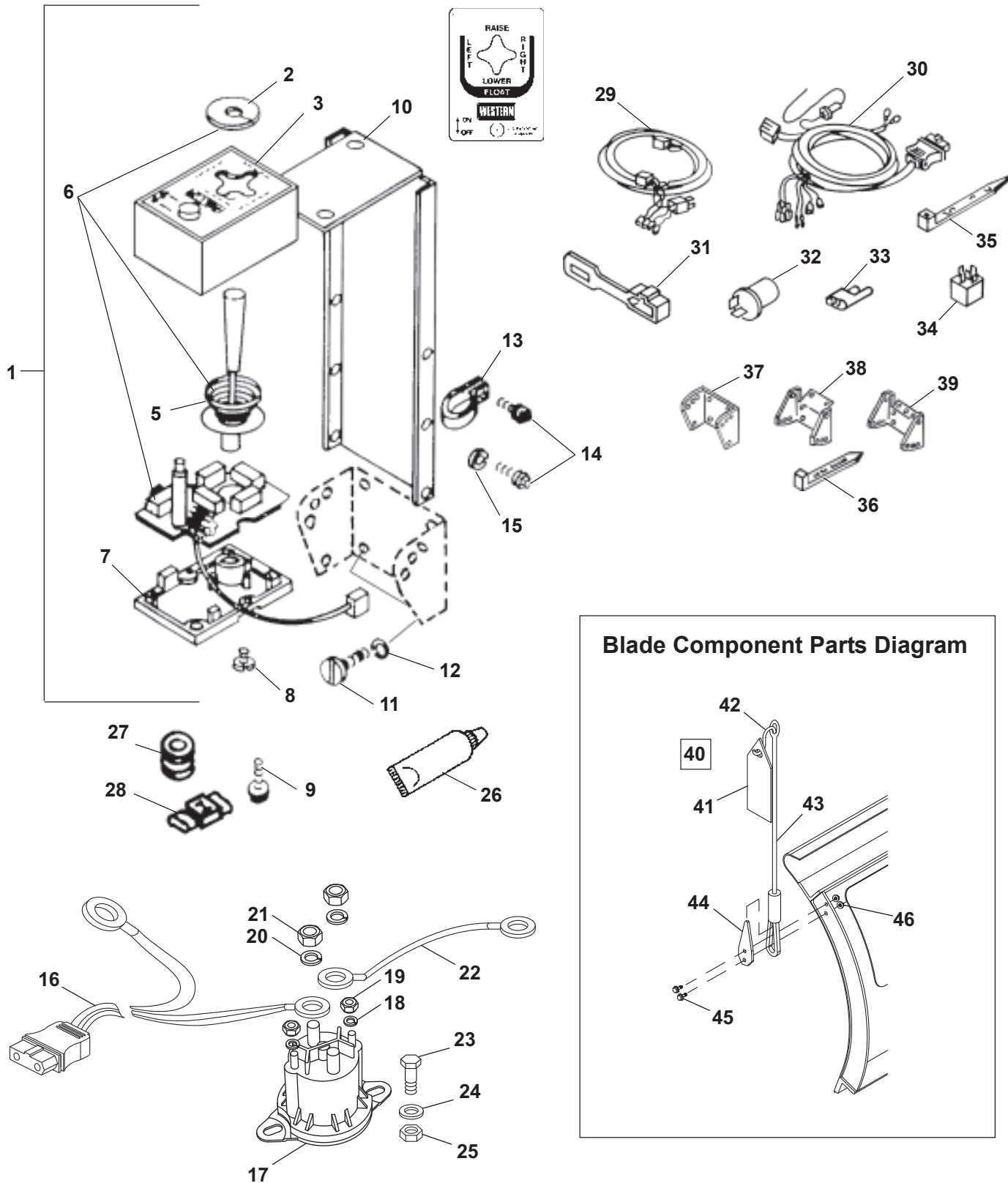



PARTS LIST

Vehicle Components Parts List

ITEM	PART NO.	QTY.	DESCRIPTION
1	56369	1	SOLENOID CONTROL KIT
2	. 56283	1	SHIELD
3	. 49286	1	BODY W/LABEL & LENS (Style 2)
5	. 55923	1	SPRING - CONICAL
6	. 56369	1	SOLENOID CONTROL KIT
	. 49283***	1	PC BOARD – MOLEX Style 2 WHITE W/LEVER ASSY AND SHIELD
7	. 56199	1	BASE
8	. 93153	2	#6-19X3/8 SL HW Tfts HILO
9	93154	2	#8-18X5/8 SL HW Tfts HILO BPO
10	56308	1	CONTROL BRACKET
11	90388	4	#10X1 PH PN Tfts TY AB BZP
12	91242	4	#10 SP LK WASHER BZP
13	55381	1	CABLE CLAMP
14	93157	5	#8-32X3/8 SL HW Tcts TY T BP
15	91231	4	#8 SP LK WASHER BP
16	61169	1	VEHICLE CABLE ASSEMBLY
17	56131K-1	1	MOTOR RELAY KIT
18	. 91242	2	#10 SP LK WASHER BZP
19	. 91402	2	#10-32 HX NUT ZYC
20	. 91202	2	5/16 SP LK WASHER ZYC
21	. 92842	2	5/16-24 HX JAM NUT ZYC
22	22511	1	BATTERY CABLE 22" RED
	20681	1	BATTERY CABLE 50"
23	90461	2	1/4-20X3/4 HX CS G5 ZYC
24	91101	2	1/4 PLAIN WASHER TY A STD ZYC
25	91331	2	1/4-20 PT HX LK NUT NYIS ZYC
26	56099	1	DIELECTRIC GREASE TUBE
	49326	1	WESTERN® DIELECTRIC GREASE TUBE (2 ounce)
27	66130	2	RUBBER GROMMET
28	59114	1	SELF STRIP WIRE CONNECTOR
29	61546	1	PLUG-IN HARNESS 2B/2D U -A
	61556	1	PLUG-IN HARNESS 2B/2D U -B
	61731	1	PLUG-IN HARNESS 2B/2D U -C
	62511	1	PLUG-IN HARNESS 2B/2D LG U -A
	62521	1	PLUG-IN HARNESS 2B/2D LG -B
	61576	1	PLUG-IN HARNESS 2E U -C
	61566	1	PLUG-IN HARNESS 1A & 2A U -A
	61571	1	PLUG-IN HARNESS HB-1 (9004) U -A
	62526	1	PLUG-IN HARNESS HB-1 (9004) U -C
	26009	1	PLUG-IN HARNESS HB-1 (9004) -F
	61591	1	PLUG-IN HARNESS HB-5 -A
	26027	1	PLUG-IN HARNESS HB-5/HB-1 -F
	63413	1	PLUG-IN HARNESS HB-5 -G
	61716	1	PLUG-IN HARNESS HB-3 & HB-4 U -A
	61586	1	PLUG-IN HARNESS HB-3 & HB-4 U -B
	26071	1	PLUG-IN HARNESS HB 3 & 4 -F
	61581	1	PLUG-IN HARNESS LF & UF U -A
30	62502	1	VEHICLE HARNESS KIT 7-PIN
	61437	1	VEHICLE HARNESS KIT 9-PIN
	62512	1	VEHICLE HARNESS KIT 9-PIN LG U
	61557	1	VEHICLE HARNESS KIT 12-PIN
	62522	1	VEHICLE HARNESS KIT 12-PIN LG U
**	61185	1	PARK OR TURN HARNESS KIT
**	61584	1	DRL KIT

Blade Component Parts List

ITEM	PART NO.	QTY.	DESCRIPTION
31	61548	2	PLUG COVER
32	60109	1	FLASHER HD
33	59224	3	BULLET RECEPTACLE CONNECTOR
34	61535	2	RELAY SPDT
35	59223	8	CABLE TIE
36	61536	2	CABLE TIE - LONG
37	56080	1	DASH BRACKET
38	56081	1	DASH BRACKET
39	56082	1	DASH BRACKET
40	59697	2	BLADE GUIDE ROD, S-HOOK & FLAG
41	. 59694K	1	BLADE GUIDE FLAG
42	. 59696	1	S-HOOK
43	. 59691	1	BLADE GUIDE ROD
44	59946	2	CLAMP
45	68494	4	5/16-18X1 HX CS G5 ZYC
46	91332	4	5/16-18 PT HX LK NUT NYIS ZYC
**	61845K	1	4' CONTROL HARNESS EXTENSION
**	66760K	1	V-PLOW ADAPTER CABLE KIT (MVP® Blade to Straight Blade Control)
**	62392	1	HARNESS CONTROL BOX ADAPTER (Old Style SAE Controls to Molex Adapter)

\*\* Not Shown

\*\*\* PC Board and lever must be replaced as a matched set.

Indented parts are included in the assembly under which they are listed. Quantities shown are included with the assembly.

For a list of abbreviations, see page 5.







Western Products  
PO Box 245038  
Milwaukee, WI 53224-9538

 A DIVISION OF DOUGLAS DYNAMICS, L.L.C.

Copyright © 2012 Douglas Dynamics, L.L.C. All rights reserved. This material may not be reproduced or copied, in whole or in part, in any printed, mechanical, electronic, film or other distribution and storage media, without the written consent of Western Products. Authorization to photocopy items for internal or personal use by Western Products outlets or snowplow owner is granted.

Western Products reserves the right under its product improvement policy to change construction or design details and furnish equipment when so altered without reference to illustrations or specifications used. Western Products or the vehicle manufacturer may require or recommend optional equipment for snow removal. Do not exceed vehicle ratings with a snowplow. Western Products offers a limited warranty for all snowplows and accessories. See separately printed page for this important information. The following are registered (®) or unregistered (™) trademarks of Douglas Dynamics, L.L.C.: Hydra-Turn®, ISARMATIC®, MVP®, POLY PRO-PLOW®, PRO-PLOW®, UniMount®, WESTERN®.

**Printed in U.S.A.**