



Fisher Engineering

P.O. Box 529 Rockland, Maine 04841

July 1, 2004
Lit. No. 63890



Attachment Kit Installation Instructions

Ford Super Duty 250, 350, 450, 550

1999-2004

⚠ CAUTION

Read this document before installing the snowplow.

⚠ CAUTION

See your FISHER® outlet for application recommendations. The Kit Selection Guide has specific vehicle and snowplow requirements.

7159-2

SAFETY INFORMATION

⚠ WARNING

Indicates a potentially hazardous situation that, if not avoided, could result in death or serious personal injury.

⚠ CAUTION

Indicates a situation that, if not avoided, could result in damage to product or property.

NOTE: Identifies tips, helpful hints, and maintenance information the owner/operator should know.

SAFETY PRECAUTIONS

Improper installation and operation could cause personal injury, and/or equipment and property damage. Read and understand labels and the *Owner's Manual* before installing, operating, or making adjustments.

⚠ WARNING

Lower blade when vehicle is parked. Temperature changes could change hydraulic pressure, causing the blade to drop unexpectedly or damaging hydraulic components. Failure to do this can result in serious personal injury.

⚠ WARNING

Remove blade assembly before placing vehicle on hoist.

⚠ WARNING

The driver shall keep bystanders clear of the blade when it is being raised, lowered or angled. Do not stand between the vehicle and the blade or within 8 feet of a moving blade. A moving or falling blade could cause personal injury.

⚠ WARNING

Keep hands and feet clear of the blade and A-frame when mounting or removing the snowplow. Moving or falling assemblies could cause personal injury.

⚠ WARNING

Do not exceed GVWR or GAWR including blade and ballast. The rating label is found on driver-side vehicle door cornerpost.

⚠ CAUTION

Refer to the Kit Selection Guide for minimum vehicle recommendations and ballast requirements.

⚠ CAUTION

To prevent accidental movement of the blade, always turn the ON/OFF switch to OFF whenever the snowplow is not in use. The control indicator light will turn off.

PERSONAL SAFETY

- Wear only snug-fitting clothing while working on your vehicle or snowplow.
- Do not wear jewelry or a necktie, and secure long hair.
- Wear safety goggles to protect your eyes from battery acid, gasoline, dirt and dust.
- Avoid touching hot surfaces such as the engine, radiator, hoses and exhaust pipes.
- Always have a fire extinguisher rated BC handy, for flammable liquids and electrical fires.

FIRE AND EXPLOSION

⚠ WARNING

Gasoline is highly flammable and gasoline vapor is explosive. Never smoke while working on a vehicle. Keep all open flames away from gasoline tanks and lines. Wipe up any spilled gasoline immediately.

Be careful when using gasoline. Do not use gasoline to clean parts. Store only in approved containers away from sources of heat or flame.

VENTILATION



⚠ WARNING

Vehicle exhaust contains deadly carbon monoxide (CO) gas. Breathing this gas, even in low concentrations, could cause death. Never operate a vehicle in an enclosed area without venting exhaust to the outside.

TORQUE CHART

⚠ CAUTION

Read instructions before assembling. Fasteners should be finger tight until instructed to tighten according to the torque chart. Use standard methods and practices when attaching snowplow including proper personal protective safety equipment.

Recommended Fastener Torque Chart (Ft.-Lb.)			
Size	 SAE Grade 2	 SAE Grade 5	 SAE Grade 8
1/4-20	6	9	13
5/16-18	11	18	28
3/8-16	19	31	46
3/8-24	24	46	68
7/16-14	30	50	75
1/2-13	45	75	115
9/16-12	66	110	165
5/8-11	93	150	225
3/4-10	150	250	370
7/8-9	150	378	591
1-8	220	583	893
Metric Grade 8.8 (Ft.-Lb.)			
Size	Torque	Size	Torque
M 6	7	M 12	60
M 8	17	M 14	95
M 10	35	M 16	155
These torque values apply to fasteners except those noted in the instruction.			

7159-2

INSTALLATION INSTRUCTIONS

1. **Vehicles equipped with BlockerBeam™:**
Remove the three fasteners on each side from the beam support bracket and remove the beam. Reattach all fasteners to the beam and affix tag 66871 using the cable tie provided. Beam must be transferred when vehicle is sold or traded.

Driver Side Shown

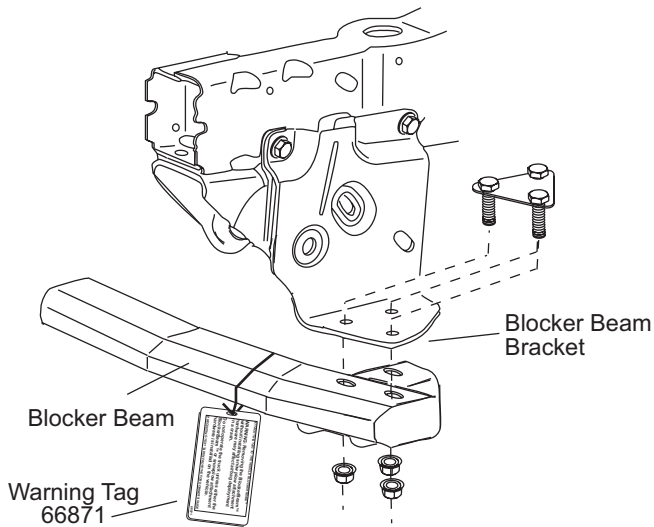
**⚠ WARNING**

Removing the BlockerBeam™ without installing snow plow attachment hardware may affect air bag deployment in a crash. Do not operate the truck unless either the BlockerBeam™ or the snow plow attachment hardware is installed on the vehicle.

2. Remove bumper by first detaching rubber flap and any electrical cords attached to bumper (vehicles with fog lamps and diesels). Remove the bumper fasteners and slide bumper forward until it is clear of the tow hooks. Remove and discard the two thin plates hanging from the bumper mounts.

3. Starting with the driver-side pushplate, position the rear section in place by fitting the pushplate between the leaf springs and the frame. On some vehicles it will be necessary to jack up the frame slightly to gain more clearance between the frame and the springs. Check for and eliminate any interference with Ford nut retainers on bottom of frame.

⚠ CAUTION

To avoid damaging A/C condensers, use care when installing pushplates on vehicles with air conditioning. Heads of bolts should be on the inside, with nuts on the outside of 22289 bracket, to increase clearance with condenser.

4. Once the rear section is in place, rotate the front section of the pushplate into place and loosely secure by attaching a bracket (22289) with two 1/2" x 1-1/4" caps screws, Gr. 8 flat washers, and locknuts. Heads of bolts should be on the inside, when vehicle is equipped with A/C condenser. Slide pushplate rearward to accomplish this. Loosely attach front of pushplate to bumper plate on frame using 1/2" x 1-1/2" cap screws, flat washers and locknuts.
5. **For F-250, F-350, and all other vehicles with swaybar bracket:** Loosely attach rear of pushplate to swaybar bracket using 1/2" x 1-1/2" cap screws, one Gr. 8 flat washer on top of swaybar bracket and one on bottom of pushplate slotted hole, and locknuts.
For F-450, F-550, and all vehicles without swaybar bracket: Proceed to step 6.
6. Repeat step 2-4 on passenger side.

NOTE: It is not always necessary to jack the frame up for additional clearance between the leaf springs and frame on the passenger side.

7. Loosely attach cross bar between both pushplates using 1/2" x 1-1/2" cap screws, Gr. 8 flat washers, and locknuts.

8. With the pushplate fit snugly into position, clamp the brackets (22289) to the top surface of the frame. Make sure the bracket is flush with the top frame surface and the shim welded to the bracket is flush with the smaller boxed frame section. Tighten the fasteners at the front of the pushplate where it meets the bumper plate. These fasteners should now be toward the tops of the slotted holes in the bumper plate.

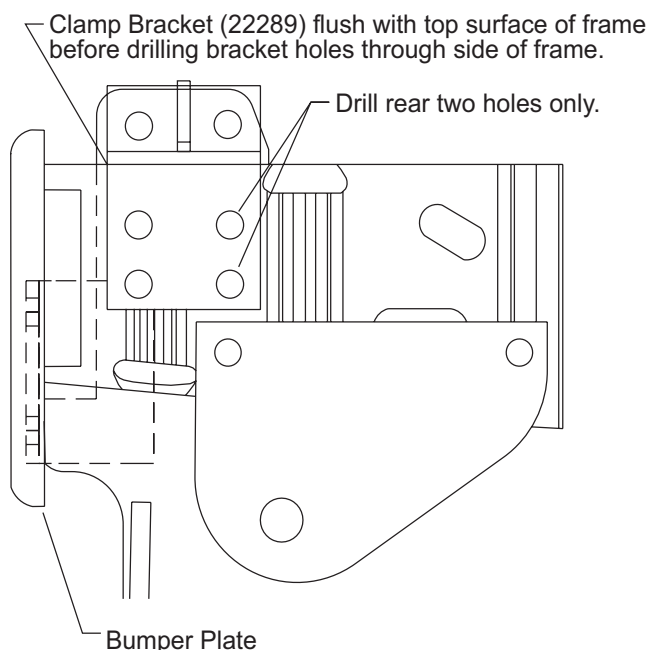

9. Attach rear of pushplate.

For F-250, F-350, and all other vehicles with swaybar bracket: With the rear of the pushplate fit snugly against both the side and bottom of the frame, tighten fasteners running through swaybar bracket. Mark and drill two 17/32" holes through the side of the frame using pushplate holes as guides. Fasten securely using two 1/2" x 1-1/2" cap screws with handles, lock washers, and nuts.

NOTE: To ensure a snug fit, loosen the swaybar bracket fasteners before tightening the cap screws with handles, then re-tighten the bracket fasteners.

For F-450, F-550, and all vehicles without swaybar bracket: With the rear of each pushplate fit snugly against both the side and the bottom of the frame, mark and drill two 9/16" holes through bottom of frame using pushplate holes as guides. To facilitate drilling, remove pushplates and drill smaller pilot holes to start. Holes must be drilled at an angle. Place a bushing between the pushplate and frame, centered over the rear hole. Fasten securely using two, 1/2" x 1-1/2" cap screws with handles, lock washers, and nuts. Mark and drill two, 17/32" holes through the side of the frame using pushplate holes as guides. Fasten securely using two, 1/2" x 1-1/2" cap screws with handles, lock washers, and nuts.

10. Drill the two rear holes in the brackets (22289) and fasten using 1/2" x 1-1/2" cap screws, Gr. 8 flat washers, and locknuts. Tighten all fasteners at this time per torque chart provided.

NOTE: Front holes in bracket (22289) are not used at any time.

11. Use the cable ties to tie up cooling lines on the driver side, forward of the front-most radiator. It is important to provide sufficient clearance between all portions of the cooling lines and the driver-side pushplate.

NOTE: Use anti-chafing material in those situations where sufficient clearance cannot be obtained.

12. Place 1/2" shims in place to space the bumper forward of the frame. Reinstall bumper and re-attach any rubber flaps or electrical cords removed during bumper removal.

NOTE: After five to ten hours of snowplow usage, retorque all attachment assembly fasteners.

7159-2

Fisher Engineering reserves the right under its product improvement policy to change construction or design details and furnish equipment when so altered without reference to illustrations or specifications used. Fisher Engineering and the vehicle manufacturer may require and/or recommend optional equipment for snow removal. Do not exceed vehicle ratings with a snowplow. Fisher Engineering offers a limited warranty for all snowplows and accessories. See separately printed page for this important information. The following are registered (®) trademarks of Douglas Dynamics, L.L.C.: FISHER®, Minute Mount®, Minute Mount® 2.

Printed in USA