

**INLET FITTING/FILTER KIT
HYDRAULIC PUMP KIT
HYDRAULIC PUMP KIT**

**66763-1
21501-1 OR 21501K-1
27746**

**PARTS LISTS AND DIAGRAMS – STRAIGHT BLADE (EXCEPT MUX w/SCRAPE LOCK)
AND 6-VALVE V-PLOWS ONLY**

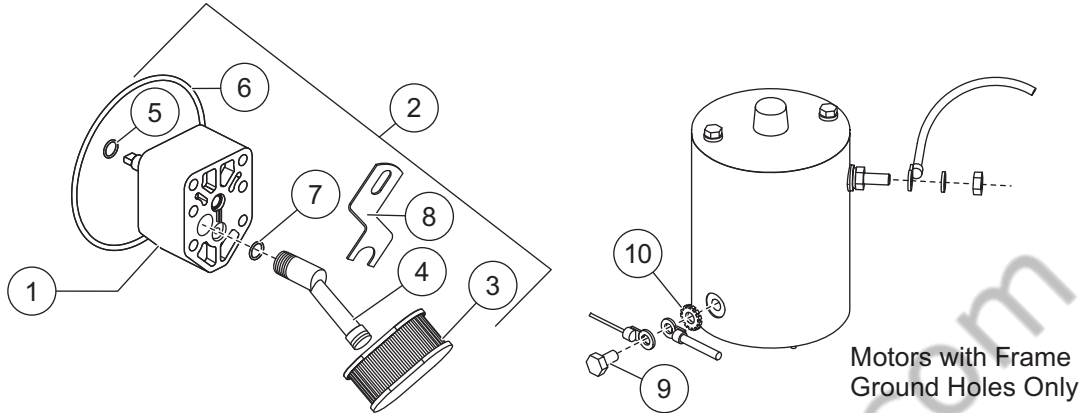

21501-1 or 21501K-1 Hydraulic Pump Kit – Straight Blade (Except MUX w/Scrape Lock) and 6-Valve V-Plow							
Item	Qty	Description	Item	Qty	Description		
1	1	Hydraulic Pump	2	1	Inlet Fitting/Filter Kit (66763)		
27746 Hydraulic Pump Kit – Personal Plow							
Item	Qty	Description	Item	Qty	Description		
1	1	Hydraulic Pump	2	1	Inlet Fitting/Filter Kit (66763)		
66763 Inlet Fitting/Filter Kit							
3	1	Suction Filter – Oval	6	1	O-Ring 2-250		
4	1	Inlet Fitting	7	1	O-Ring -014		
5	1	O-Ring -013	8	1	Retainer Clip		
Parts Not Included In Kit – Sold Separately							
Item	Part	Qty	Description	Item	Part	Qty	Description
9	90088	1	5/16-18 x 1/2 Hex Cap Screw	10	91263	1	5/16 External Lock Washer

Straight Blade (Except MUX w/Scrape Lock) and 6-Valve V-Plow

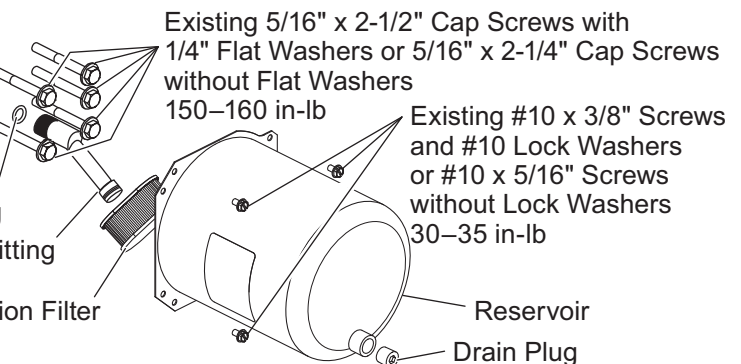
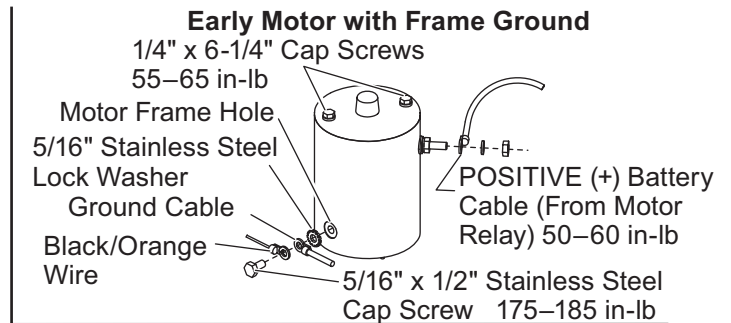
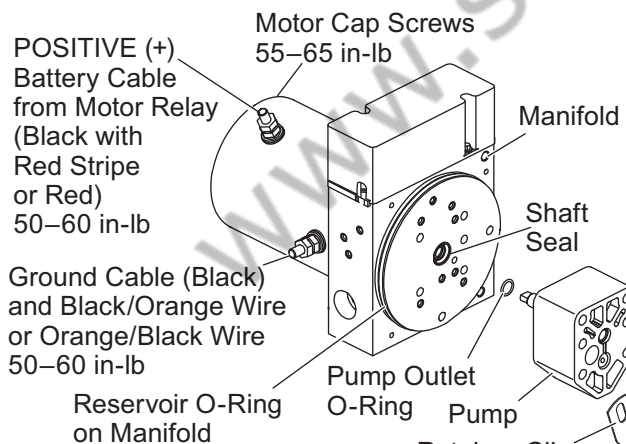

**INLET FITTING/FILTER KIT
HYDRAULIC PUMP KIT
HYDRAULIC PUMP KIT**

**66763-1
21501-1 OR 21501K-1
27746**

Personal Plow

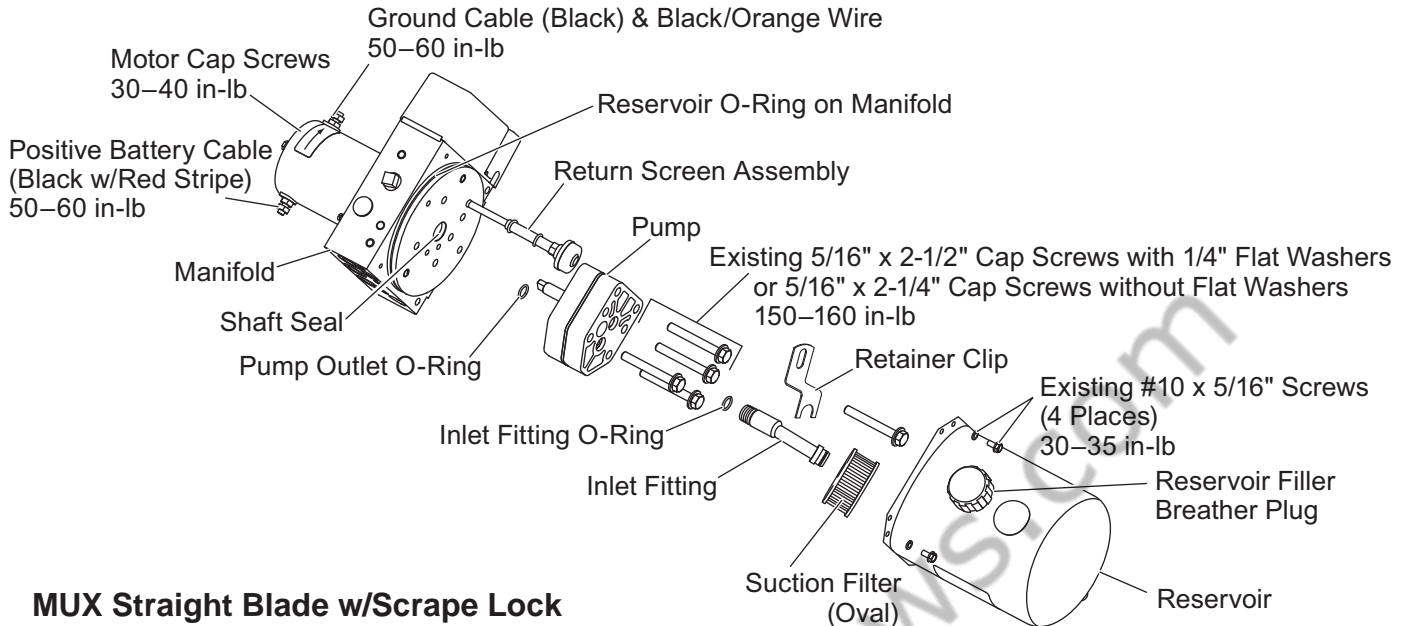

MUX Straight Blade w/Scrape Lock

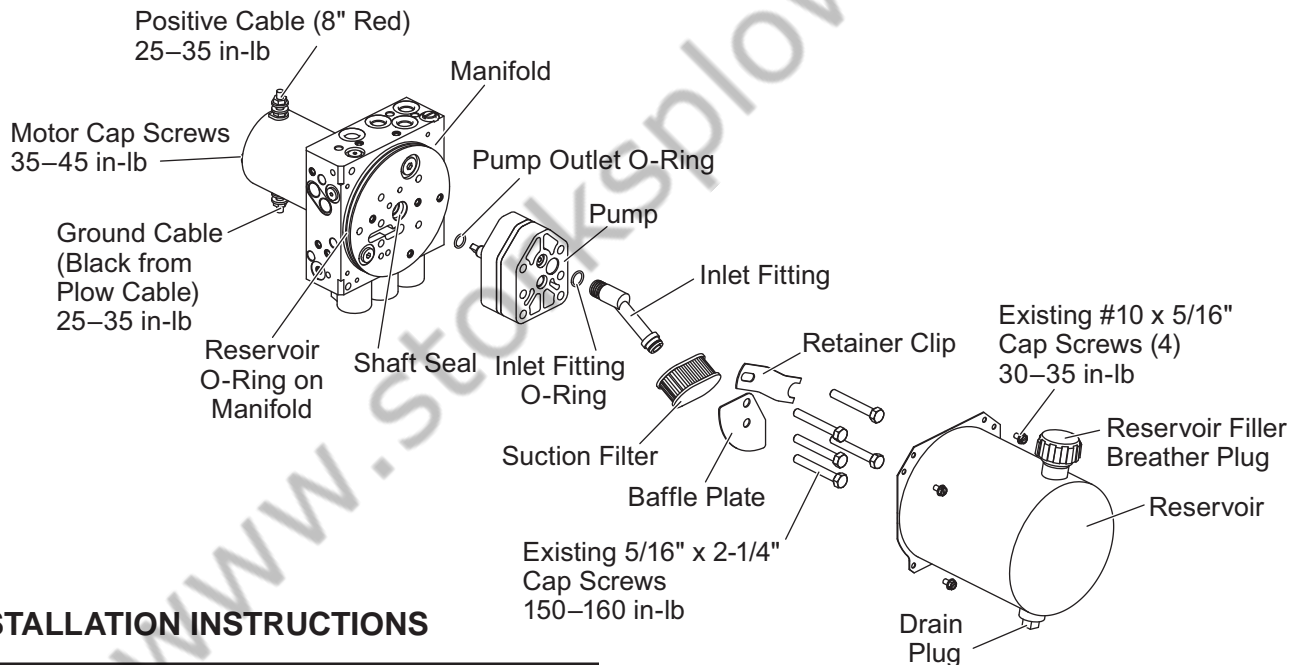

INSTALLATION INSTRUCTIONS

NOTE: Poor motor grounds may result in pump failures. When replacing pump, insure that all ground connections are clean and free of paint and corrosion. Use dielectric grease on all electrical connections to prevent corrosion. Fill receptacles and lightly coat ring terminals before assembly.

Instructions cover complete replacement of pump, inlet fitting and suction filter. Use appropriate steps for components being serviced.

1. Lower blade to floor.
2. **For Straight Blades and V-Plows:** Fully retract lift ram (single-acting ram only). Loosen reservoir fill plug slowly to vent residual pressure. Drain fluid from reservoir through drain plug. Position hydraulic unit so reservoir can be removed.

For Personal Plows: Disconnect 8" hydraulic hoses from reservoir fitting and drain fluid from reservoir.

- Remove four reservoir mounting screws and reservoir. Remove five cap screws from pump and carefully remove pump from manifold. Remove and discard reservoir O-ring from manifold. Clean pump mounting surface, O-ring groove and reservoir.

NOTE: Replacement pump includes a .75 OD alignment ring that fits in a counter-bore around the shaft. Install alignment ring only if the pump shaft seal is recessed approximately .15" below the pump mounting surface of the manifold.

If seal is nearly flush with mounting surface, discard alignment ring. Do not attempt to drive seal deeper as it is bottomed in the bore.

- Remove the protective plug from the counter-bored hole. Remove rubber band holding the pump sections together. Lubricate the -013 O-ring (smaller of the two small O-rings in kit) and place it into counter-bored hole. Place seal protector on pump shaft. Carefully insert pump shaft into shaft seal in the manifold block. Fit pump alignment ring into shaft seal bore if used. If shaft side of pump is not flush to manifold surface, gently rotate pump body until pump shaft tang enters motor shaft slot. Align pump body with cap screw holes in manifold block. Secure pump to manifold with existing fasteners. Alternately tighten cap screws to 150–160 in-lb torque.

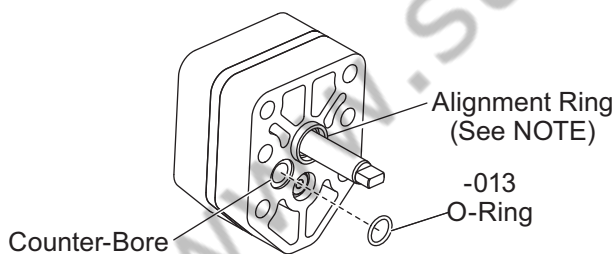

- Lubricate the -014 O-ring, (larger of the two small O-rings in kit) and assemble O-ring into the groove on the barbed end of the inlet fitting. Snap the suction filter onto the other end of the inlet fitting. Remove the protective plug from the cap-screw-head side of the pump body. Position the inlet fitting assembly as shown below for the snowplow being serviced. Gently drive the barbed end of the inlet fitting squarely into the pump housing until the O-ring is not visible. Fitting and filter can be rotated into final position after installation.
- Remove indicated cap screw and install retainer clip over inlet fitting and under cap screw (and washer, if used) as shown. Tighten cap screw to 150–160 in-lb.

Straight Blade Snowplows and Personal Plow (except MUX w/Scrape Lock) MUX Straight Blade Snowplows w/Scrape Lock

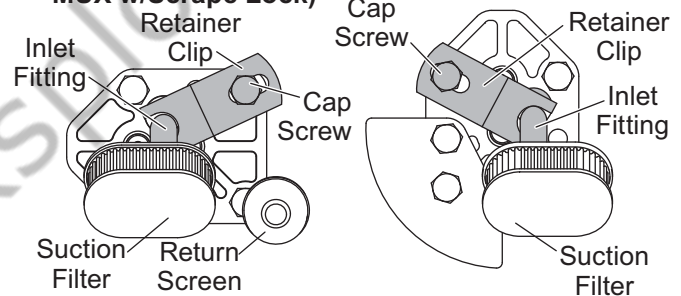

V-Plows with Vertically Mounted Hydraulic Unit V-Plows with Horizontally Mounted Hydraulic Unit

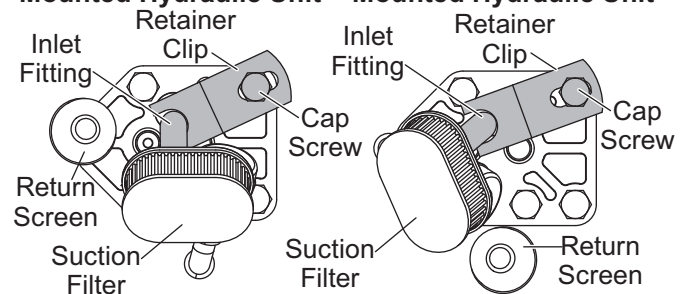

- Lubricate and install the new 2–250 reservoir O-ring (largest O-ring in kit) onto the manifold. Lubricate inside edge of reservoir and carefully press reservoir evenly over O-ring onto manifold to avoid damaging O-ring. Secure with existing fasteners tightened to 30–35 in-lb.

Flushing Fluid from Plow Rams

For Straight Blades and V-Plows:

1. Remove the hoses from the valve block. Be sure to note the port location for each hose to ensure proper reattachment.
2. Place open ends of the hoses in a container to hold the used fluid.
3. Manually move the blade so both cylinders move to a fully retracted position, and reattach the hydraulic hoses. Tighten hose fittings 1/8–1/4 turn past finger tight.
4. Fill reservoir with clean fluid through fill hole on the reservoir. Refer to the Owner's Manual or Mechanic's Guide for the proper fluid. **DO NOT** mix different types of fluid.

Actuate unit and refill reservoir. (See next step for proper filling of V-plow rams.) Adjust pump pressure relief valve if necessary. See Mechanic's Guide for the system you are servicing for details about pump pressure adjustment.

5. **V-Plows Only:** Proper filling of rams with fluid is critical to minimize aeration in the system. Follow this procedure:

- Fill reservoir with all rams retracted.
- Fully extend and retract the driver-side ram several times. Retract ram.

Fill reservoir.

- Fully extend and retract the passenger-side ram several times. Retract ram.

Fill reservoir again.

- Raise and lower the snowplow several times. Fully retract all rams and refill reservoir.

For Personal Plow:

1. Trim the reservoir filler breather plug as shown, if necessary, to prevent interference with the inlet fitting retainer clip.

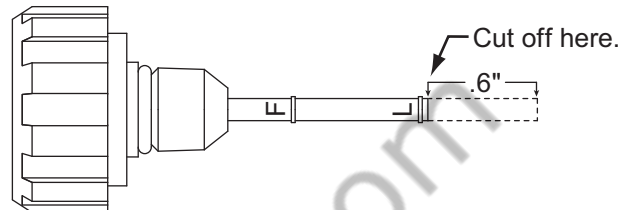

2. Place the end of the 8" hose into a suitable container. Remove used fluid from the lift ram by raising the blade with a floor jack until the ram is fully retracted. **With blade raised, reattach hose to reservoir. Tighten hose fitting 1/8–1/4 turn past finger tight. Fill reservoir to full mark on filler breather plug with new hydraulic fluid.** Refer to Owner's Manual for fluid recommendations. Lower blade to floor. The lift ram will take in fluid as it extends.
3. Note the position of the angling ram hoses on the manifold. Disconnect angle ram hoses at the manifold and place hose ends in a suitable container to catch used fluid. Manually angle the blade fully to each side to remove fluid from the rams. Do not allow hose from extending ram to take in used fluid. Reattach hoses to manifold. Tighten hose fitting 1/8–1/4 turn past finger tight.
4. Refill reservoir and angle the blade several times. Raise and lower blade several times and refill reservoir to full mark.

Copyright © 2009 Douglas Dynamics, L.L.C. All rights reserved. This material may not be reproduced or copied, in whole or in part, in any printed, mechanical, electronic, film or other distribution and storage media, without the written consent of the company. Authorization to photocopy items for internal or personal use by the company's outlets or snowplow owner is granted.

The company reserves the right under its product improvement policy to change construction or design details and furnish equipment when so altered without reference to illustrations or specifications used. Do not exceed vehicle ratings with a snowplow. The company offers a limited warranty for all snowplows. See separately printed page for this important information.

Printed in USA