

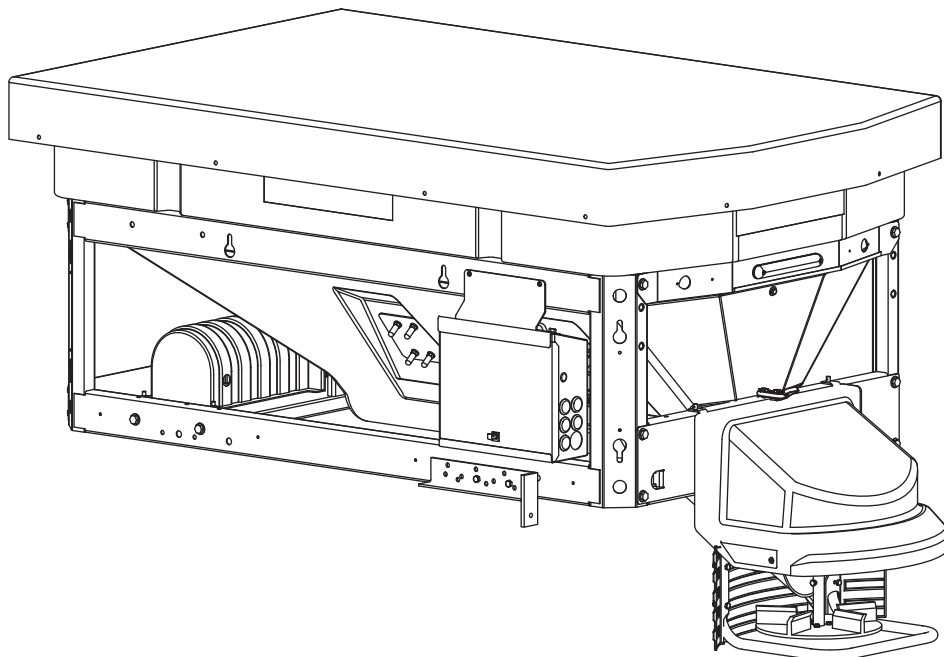

V-Maxx™ G2 Hopper Spreader VX-1500

Parts List



HOPPER ASSEMBLY

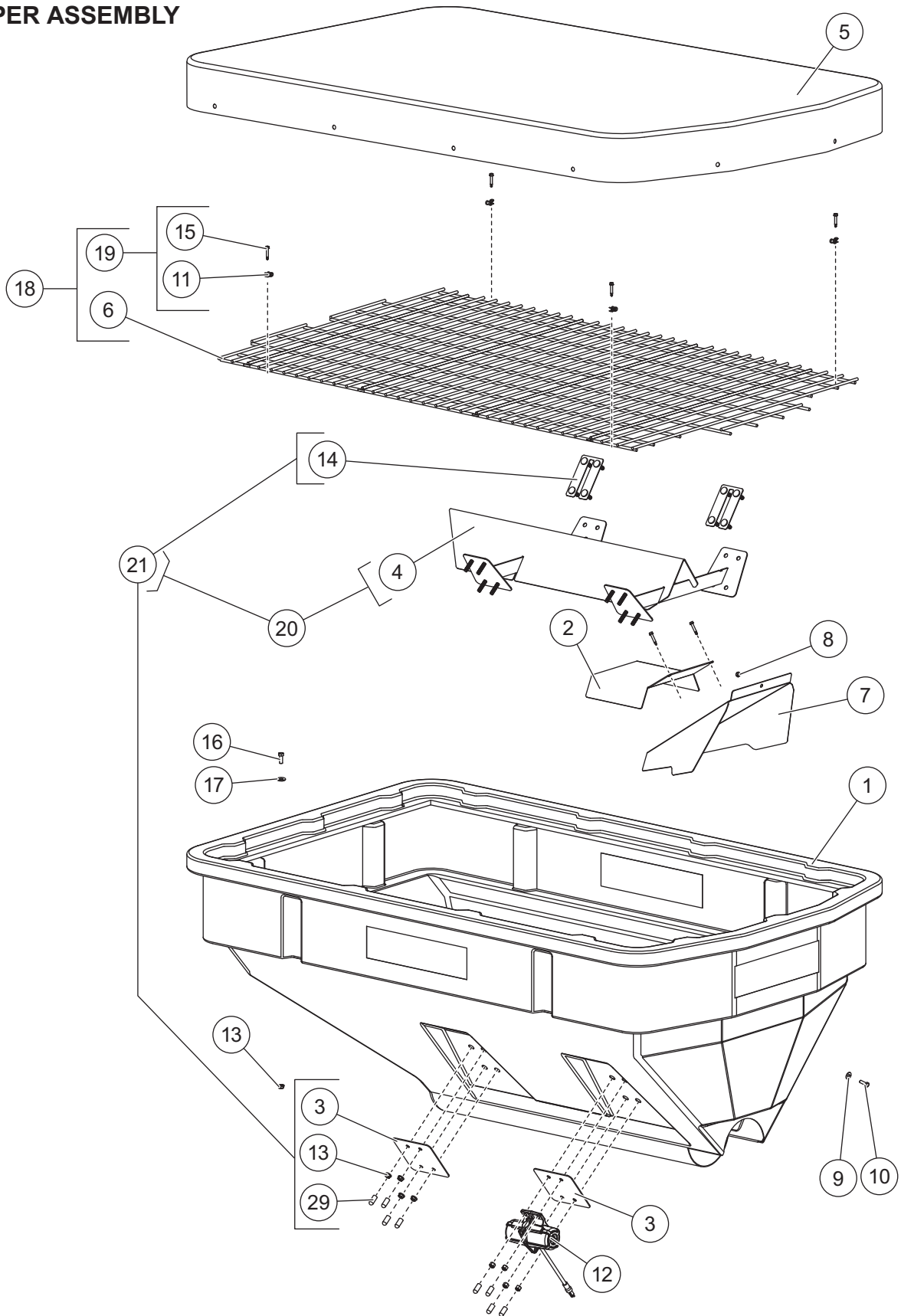

www.storksplows.com
VX-1500 HOPPER SPREADER

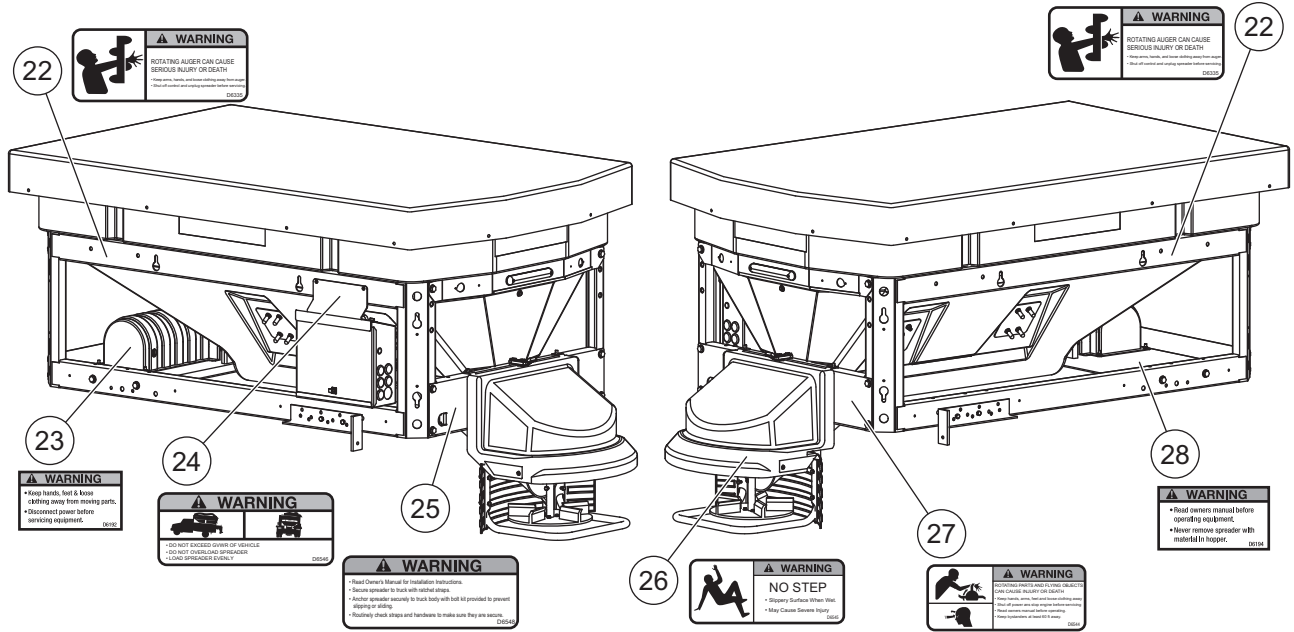

Hopper Assembly							
Item	Part	Qty	Description	Item	Part	Qty	Description
1	D5500	1	Hopper, 1.4 cu yd, Yellow	16	D4121	4	3/8-16 x 1 Hex Cap Screw
2	D5503	1	Discharge Baffle Extension	17	D4125	4	3/8 Flat Washer
3	D5508	4	Flat Inverted V Backing Plate	18	83713	1	Top Screen Kit
4	D5510	1	Inverted V	19	83719	1	Top Screen Hardware Kit
5	D5511	1	Tarp Kit	20	83714	1	Inverted V Kit
6	D5512	1	72 x 43 Top Screen	21	83721	1	Inverted V Hardware Kit
7	D5517	1	Discharge Baffle	22	D6335	1	Label – Warning, Rotating Auger
8	D6138	1	5/16-18 Locknut	23	D6192	1	Label – Warning, Hands and Feet
9	D6165	1	5/16 Flat Washer	24	D6546	1	Label – Warning, Do Not Overload
10	D6166	1	5/16-18 x 1 Hex Cap Screw	25	D6548	1	Label – Warning, Owner's Manual
11	D6509	4	5/16 Rubber Coated Clamp	26	D6545	1	Label – Warning, No Step
12	75673	1	Vibrator Kit	27	D6544	1	Label – Warning, Rotating Parts
13	D6584	20	3/8-16 Serrated Flange Nut	28	D6194	1	Label – Warning, Before Operating
14	D6815	2	Bolt Plate, 4-Bolt	ns	83691	2	Label – SnowEx® V-Maxx™ G2
15	D6874	6	1/4 x 1-1/2 Driller Screw w/Washer				
Item 18	83713 Top Screen Kit						
6	D5512	1	72 x 43 Top Screen	19	83719	1	Top Screen Hardware Kit
Item 19	83719 Top Screen Hardware Kit						
11	D6509	4	5/16 Rubber Coated Clamp	15	D6874	4	1/4 x 1-1/2 Driller Screw w/Washer
Item 20	83714 Inverted V Kit						
4	D5510	1	Inverted V	21	83721	1	Inverted V Hardware Kit
Item 21	83721 Inverted V Hardware Kit						
3	D5508	4	Flat Inverted V Backing Plate	14	D6815	2	Bolt Plate, 4-Bolt
13	D6584	16	3/8-16 Serrated Flange Nut	29	T30820	16	3/8 x 1 Stud Cover, Plastic
ns = not shown							

MOUNTING HARDWARE

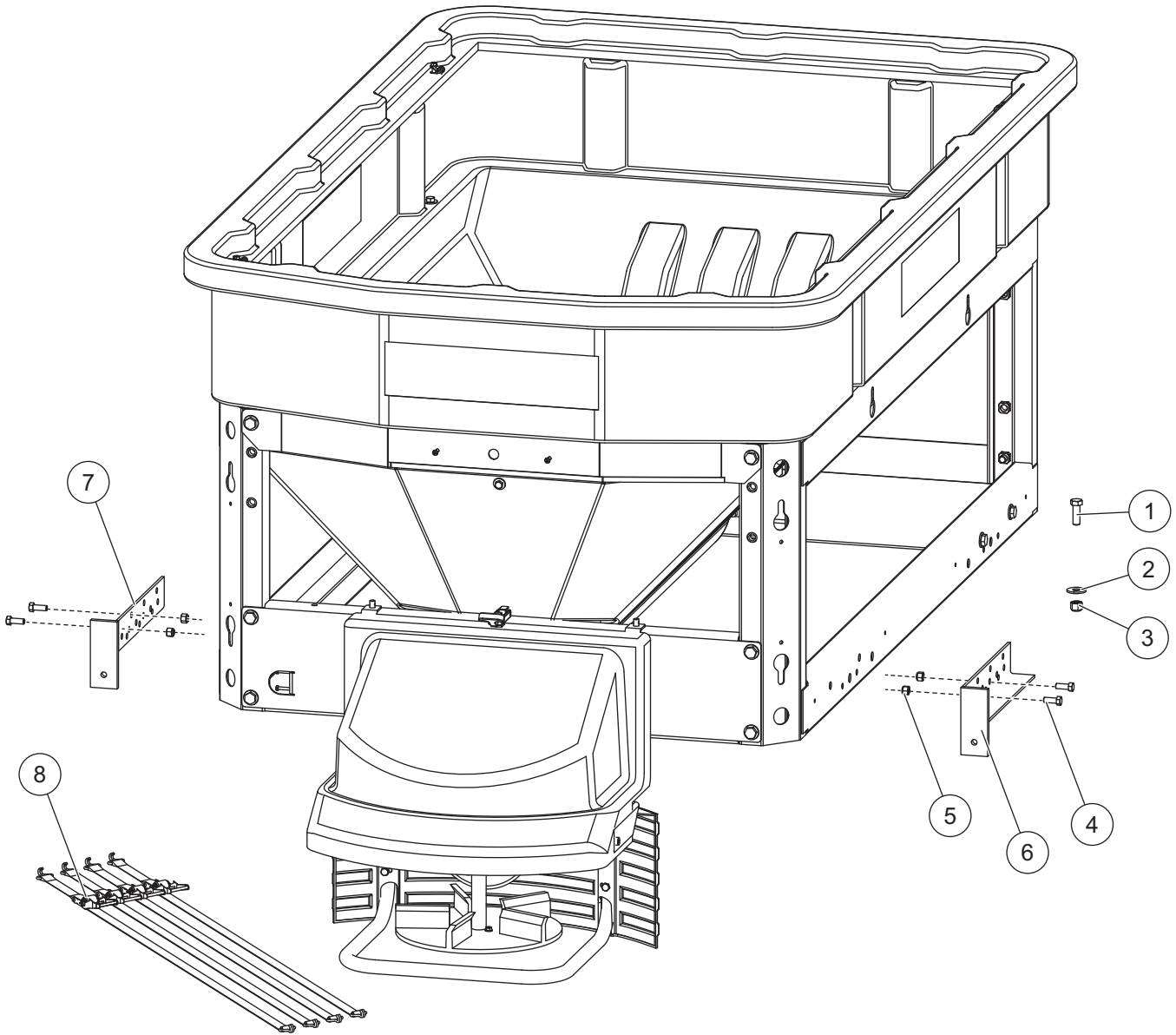

Mounting Hardware							
Item	Part	Qty	Description	Item	Part	Qty	Description
1	D4116	4	1/2-13 x 1-1/2 Hex Cap Screw	5	D4124	4	3/8 Locknut
2	D4119	4	1/2 Flat Washer	6	D6536	1	Adjustable Stop Bracket, Right
3	D4120	4	1/2-13 Locknut	7	D6537	1	Adjustable Stop Bracket, Left
4	D4121	4	3/8-16 x 1 Hex Cap Screw	8	D6856	1	V-Maxx™ Ratchet Straps (pkg of 4)

FRAME ASSEMBLY

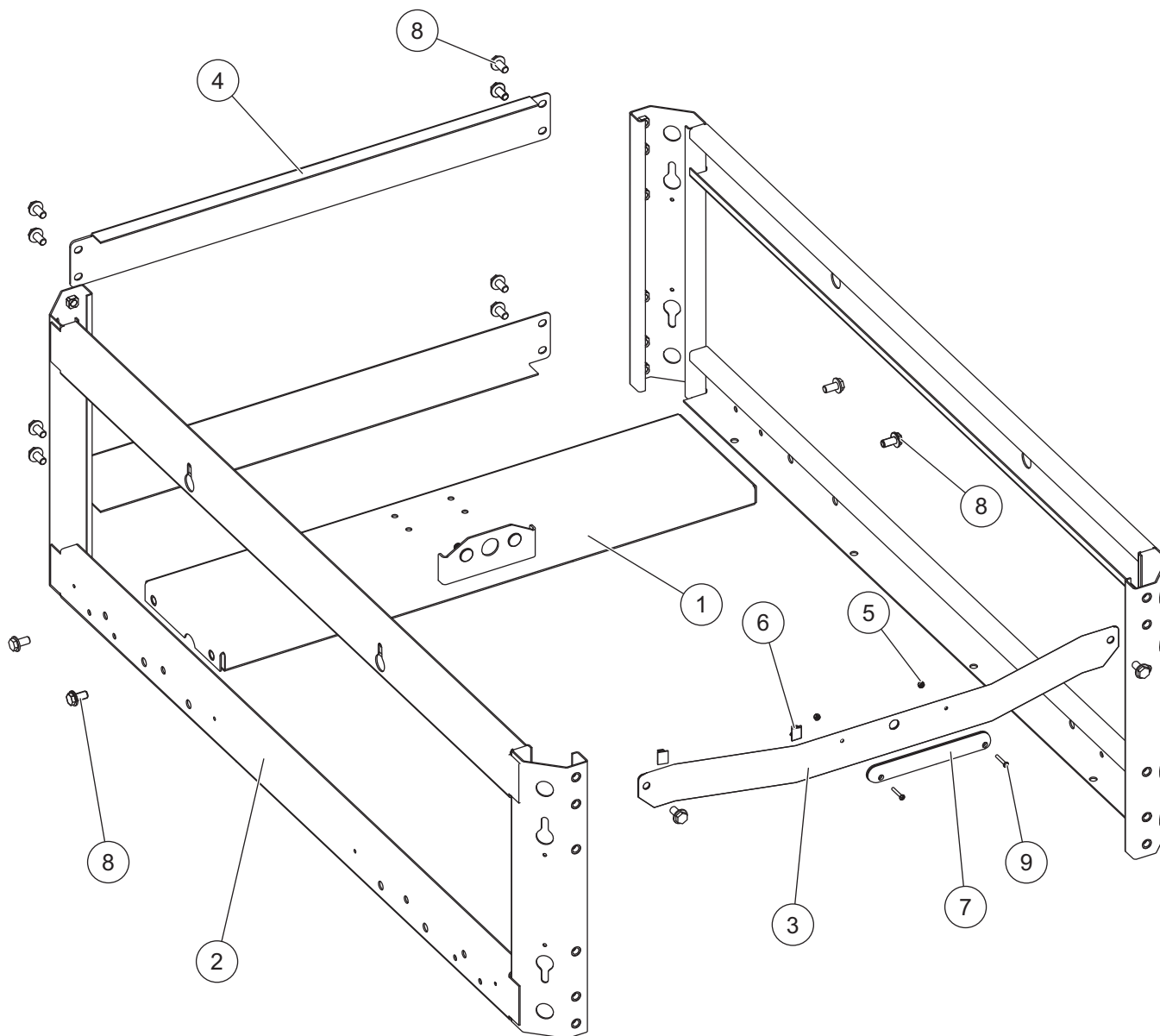

Frame Assembly							
Item	Part	Qty	Description	Item	Part	Qty	Description
1	D5504	1	Auger Drive Mounting Plate	6	D6468	2	1/4 Wire Loom Adhesive Clamp
2	D5505-1	2	Side Frame	7	D6514	1	CHMSL Brake Light
3	D5506-1	1	Rear Apron	8	D6528	14	1/2-13 x 1 Hex Cap Screw
4	D5507	2	Front Fascia	9	D6529	2	#10-32 x 1-1/4 Phillips Head Screw SS
5	D6158	2	#10-32 Locknut				

SS = Stainless Steel

AUGER DRIVE ASSEMBLY

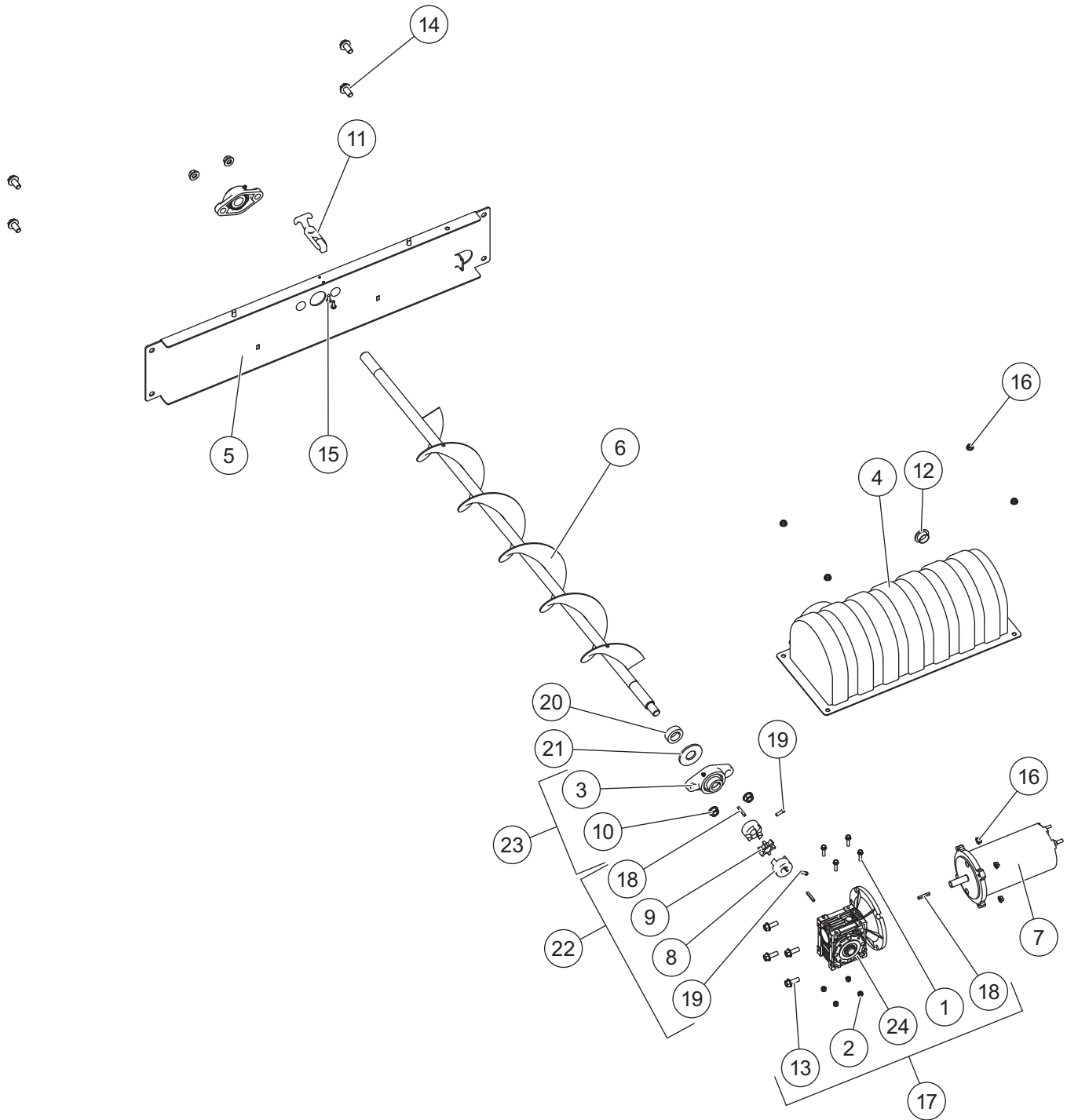

www.storksplows.com
VX-1500 HOPPER SPREADER

Auger Drive Assembly							
Item	Part	Qty	Description	Item	Part	Qty	Description
1	D6854	4	1/4-20 x 1 Hex Cap Screw Serrated Flange	13	D6452	4	3/8-16 x 1 Hex Cap Screw Serrated Flange
2	T15016	4	1/4-20 Locknut	14	D6528	4	1/2-13 x 1 Hex Cap Screw Serrated
3	D5383	2	1" 2-Bolt Flange Bearing	15	D6553	2	#10 x 3/4 Hex Washer Head Slotted Screw
4	F50957	1	Auger Motor Cover	16	D5706	8	5/16-18 Serrated Flange Nut
5	D5514	1	Spinner Drive Mount Plate	17	99798*	1	Transmission 80:1 Kit
6	D5520	1	5 x 57 x 5-8" Auger	18	D6873	3	3/16 x 1-1/4 Key Stock
7	D6825	1	1/3 HP Motor, 1750 RPM	19	D7164	2	1/4-20 x 3/4 Square Head Set Screw
8	D5532	2	Jaw Coupling Hub	20	T20315	1	1-1/16 Shaft Collar w/ Set Screw
9	D5533	1	Jaw Coupling Spider	21	T30742	1	1" Flat Washer
10	D5535	4	1/2-13 Serrated Flange Nut	22	83716	1	Coupler Kit
11	D6105	1	Flexible Draw Latch	23	83717	2	Bearing Kit
12	94299	1	Grommet				
Item 17				99798* Auger Transmission Kit			
1	D6854	4	1/4-20 x 1 Hex Cap Screw Serrated Flange	18	D6873	2	3/16 x 1-1/4 Key Stock
2	T15016	4	1/4-20 Locknut	24	10923	1	Transmission 80:1 NMRV 040
13	D6452	4	3/8-16 x 1 Hex Cap Screw Serrated Flange				
Item 22				83716 Coupler Kit			
8	D5532	2	Jaw Coupling Hub	18	D6873	2	3/16 x 1-1/4 Key Stock
9	D5533	1	Jaw Coupling Spider	19	D7164	2	1/4-20 x 3/4 Square Head Set Screw
Item 23				83717 Bearing Kit			
3	D5383	1	1" 2-Bolt Flange Bearing	10	D5535	2	1/2-13 Serrated Flange Nut

* If replacing early style black transmission, also order PN 83723 Transmission Adapter Kit.

SPINNER DRIVE ASSEMBLY

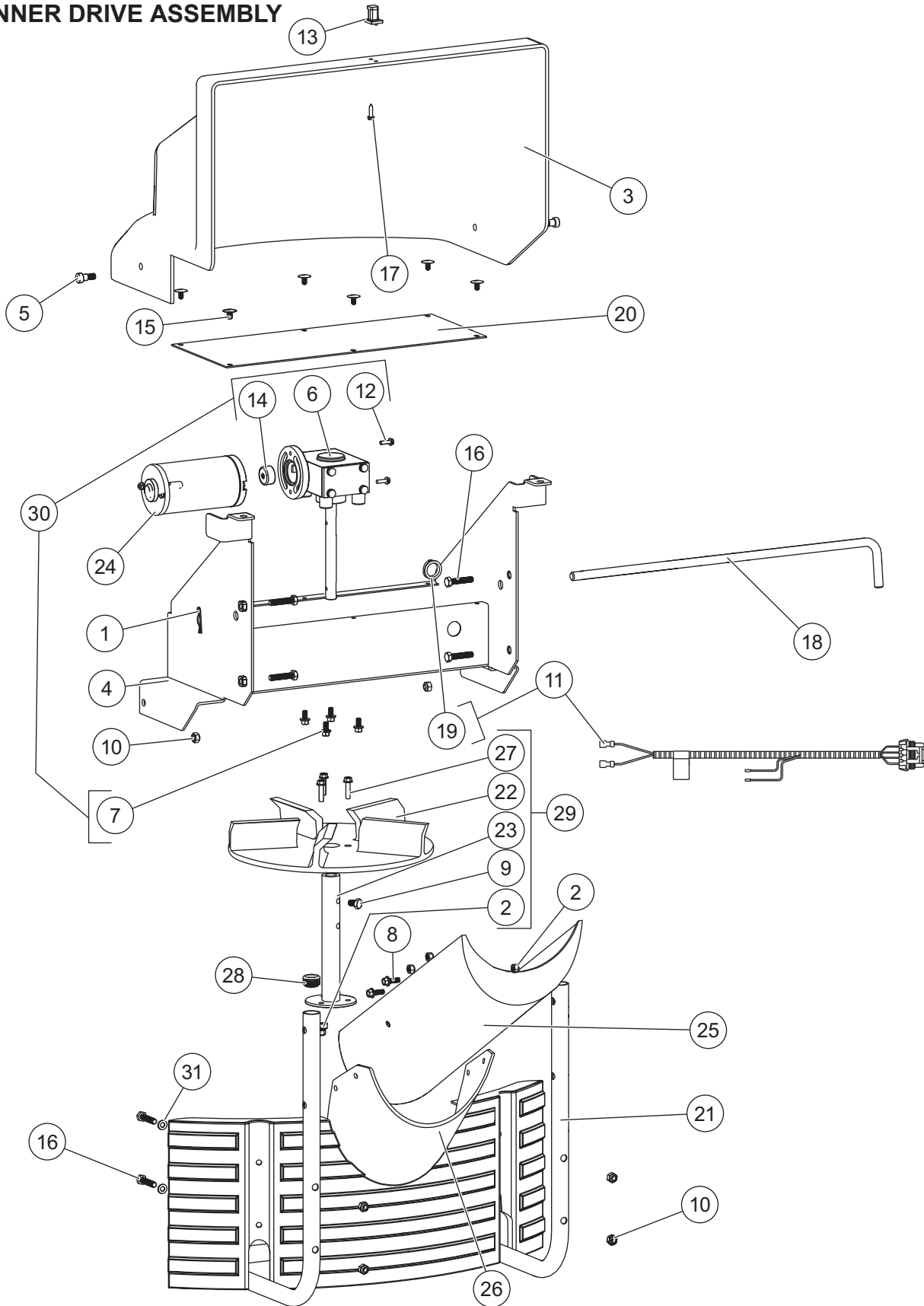

www.storksplows.com
VX-1500 HOPPER SPREADER

83718 Spinner Drive Assembly							
Item	Part	Qty	Description	Item	Part	Qty	Description
1	D4135	1	.093 x 2-3/8 Hairpin Cotter	16	D6524	8	5/16-18 x 1-1/2 Hex Cap Screw
2	T15016	7	1/4-20 Waxed Locknut	17	D6553	1	#10 x 3/4 Hex Washer Head Slotted Screw
3	D5502	1	Spinner Drive Cover	18	D6563	1	1/2 x 20 Bent Pin
4	D5518	1	Spinner Drive Enclosure	19	21651	1	#2 Rubber Grommet
5	D5536	2	3/8 x 5/16 Hex Cap Screw Socket Shoulder	20	D6819	1	Spinner Drive Enclosure Cover
6	D6107	1	8:1 Worm Gear Transmission	21	D6820	1	Spinner Guard Tube
7	D6131	4	1/4-20 x 1/2 Hex Cap Screw Serrated Flange SS	22	D6823	1	12 x 5/8 Spinner
8	D6132	4	1/4-20 x 3/4 Hex Cap Screw Serrated Flange SS	23	D6824	1	5/8 x 1 x 7-5/8 Spinner Hub
9	T15049	1	5/16-18 x 1/2 Hex Cap Screw	24	D6827	1	Spinner Motor
10	D6138	6	5/16-18 Locknut	25	D6832	1	Material Chute
11	78413	1	Spinner Harness	26	D6833	1	Spinner Deflector
12	D6172	2	#10-32 x 5/8 Hex Cap Screw Serrated Flange w/Patch	27	D6854	3	1/4-20 x 1 Hex Cap Screw Serrated Flange SS
13	D6198	1	Latch Keeper	28	F50438	2	Tube Plug, 1" Round
14	D6232	1	Motor Drive Coupler	29	99797	1	Spinner Hub Kit
15	D6467	6	1/4 x 3/4 x 1/2 Retainer	30	83722	1	Spinner Transmission Kit
16				31	D6165	4	5/16 Flat Washer
Item 11				78413 Spinner Harness			
		1	Spinner Harness	19	21651	1	#2 Rubber Grommet
Item 29				99797 Spinner Hub Kit			
2	T15016	3	1/4-20 Waxed Locknut	23	D6824	1	5/8 x 1 x 7-5/8 Spinner Hub
9	T15049	1	5/16-18 x 1/2 Hex Cap Screw	27	D6854	3	1/4-20 x 1 Hex Cap Screw Serrated Flange SS
22	D6823	1	12 x 5/8 Spinner				
Item 30				83722 Spinner Transmission Kit			
6	D6107	1	8:1 Worm Gear Transmission	12	D6172	2	#10-32 x 5/8 Hex Cap Screw Serrated Flange w/Patch
7	D6131	4	1/4-20 x 1/2 Hex Cap Screw Serrated Flange SS	14	D6232	1	Motor Drive Coupler
SS = Stainless Steel							

CONTROL & ELECTRICAL COMPONENTS

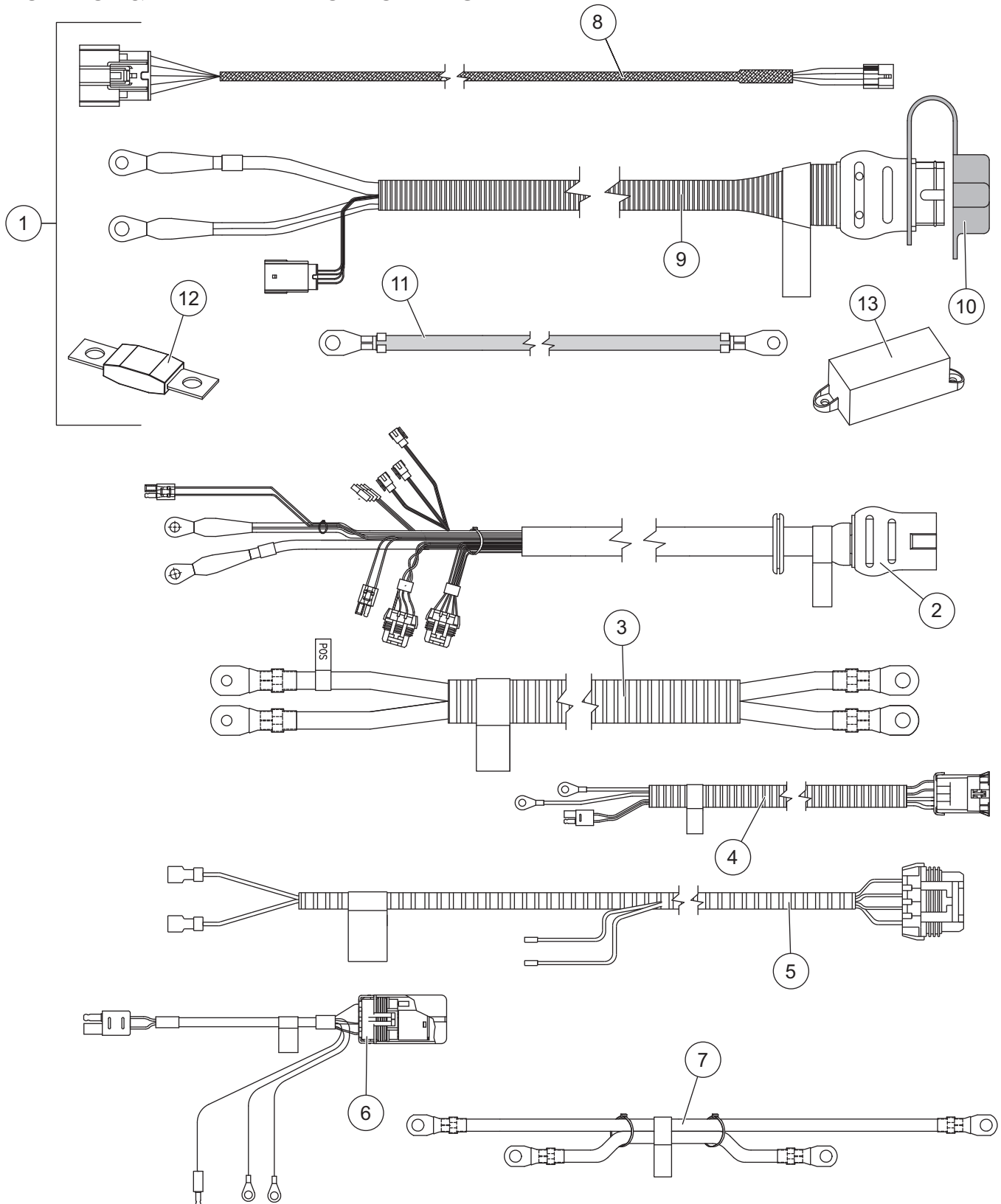

Not drawn to scale.

www.storksplows.com
VX-1500 HOPPER SPREADER

ELECTRICAL CONTROL & HARNESSSES

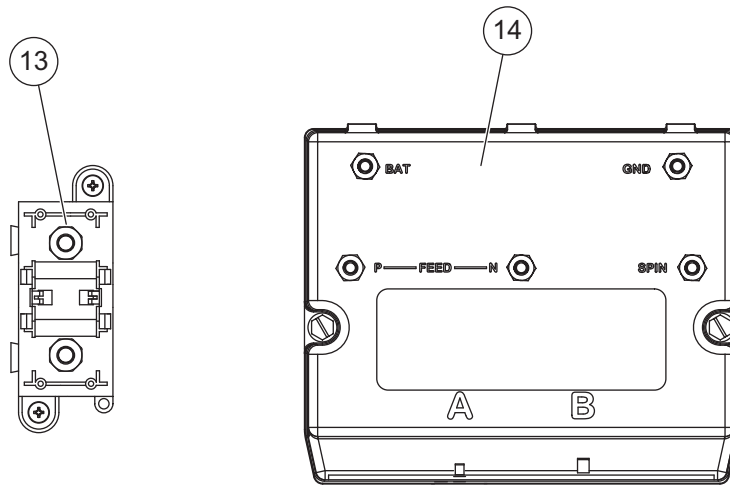

Cables & Harnessing / Electrical Enclosure Assembly							
Item	Part	Qty	Description	Item	Part	Qty	Description
1	78402	1	Vehicle Side Harness Kit	6	78382	1	Vibrator Harness Assembly
2	83688	1	Cable Assy, Hopper	7	78385	1	Cable Assy, Mod. to Isolated Stud
3	83697	1	Cable Assy, Module to Auger Motor	ns	99775	1	Cable Boot – 8-Pin
4	78415	1	Cable Assy, Spinner Motor, Hopper	ns	57116	1	Bracket, Cable Boot
5	78413	1	Harness, Spinner Chute				
Item 1				78402 Vehicle Side Harness Kit			
8	69902	1	Vehicle Control Harness	12	95836	1	Fuse, 100 A
9	76057	1	Vehicle Harness Assy (incl. item 10)	13	95837	1	Fuse Holder/Isolated Stud Block
10	99759	1	Plug Cover	ns		6	Cable Tie, HD
11	22511	1	22" Battery Cable – Red	ns		10	Cable Tie, 15.35"
Electrical Box Components							
13	95837	1	Fuse Holder/Isolated Stud Block	14	52375	1	Spreader Module, 5-Post
ns = not shown							

ELECTRICAL CONTROL & HARNESSSES

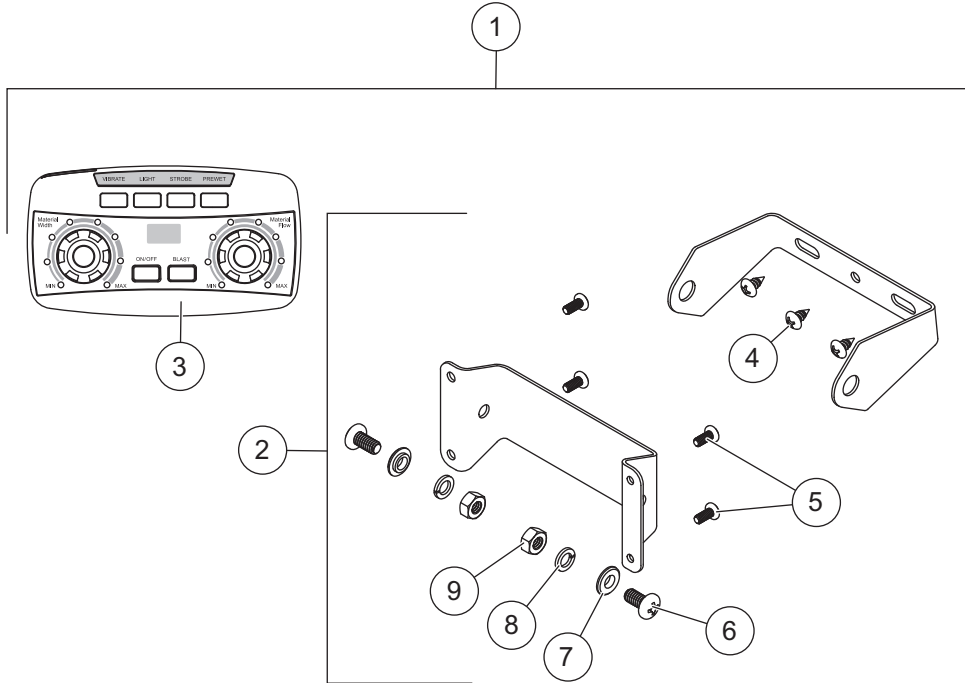

Cab Control							
Item	Part	Qty	Description	Item	Part	Qty	Description
1	52430	1	Cab Control Kit	3	52432	1	Cab Control 2-Knob
2	52345	1	Cab Control Bracket Kit				
Item 1				52430 Cab Control Kit			
2	52345	1	Cab Control Bracket Kit	3	52432	1	Cab Control 2-Knob
Item 2				52345 Cab Control Bracket Kit			
		1	Bracket, Control Inner	6		2	1/4-20 x 1/2 Pan Head Machine Screw SS – Black
		1	Bracket, Control Outer				
4		3	#10 x 3/8 Pan Head Tapping Screw SS	7		2	1/4 Shoulder Washer SS – Black
5		4	#8 x 3/8 Pan Head Machine Screw	8		2	1/4 Lock Washer SS
				9		2	1/4-20 Hex Nut G5 – Black
SS = Stainless Steel				G = Grade			

ELECTRICAL ASSEMBLY COMPONENTS

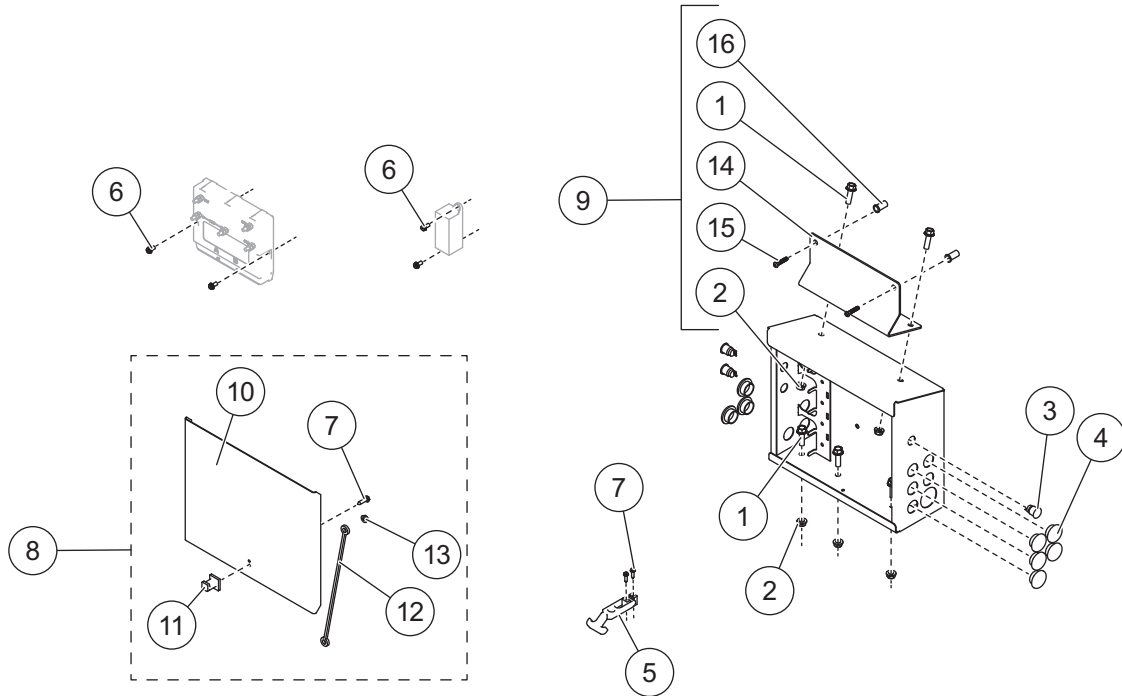

99789 Electrical Box Assembly							
Item	Part	Qty	Description	Item	Part	Qty	Description
1	83641	3	3/8-16 x 1-1/4 Serrated Flange Screw G5	6	78436	4	1/4-20 x 1/2 Washer Machine Screw SS
2	D6584	3	3/8-16 Serrated Flange Nut	7	D6553	2	#10 x 3/4 Washer Head Slotted Screw
3	99254	3	Switch, Push Button, MO	8	57016	1	Cover Assembly
4	99195	9	Break Through Plug	9	83701	1	Bracket Kit
5	D6105	1	Flexible Draw Latch	ns	83698	1	Labels – Electronic Assembly
Item 8				57016 Cover Assembly			
7	D6553	1	#10 x 3/4 Washer Head Slotted Screw	12	43554	1	12" Lanyard Loop
10	57014	1	Cover	13	88300	1	1/4-20 Serrated Flange Nut
11	D6198	1	Latch Keeper				
Item 9				83701 Bracket Kit			
1	83641	2	3/8-16 x 1-1/4 Serrated Flange Screw G5	15	57966	2	1/4-20 x 1-1/4 Hex Cap Screw SS
2	D6584	2	3/8-16 Serrated Flange Nut	16	78263	2	1/4-20 Well Nut
14		1	Support Bracket				
			SS = Stainless Steel			ns = not shown	G = Grade



TrynEx International
531 Ajax Drive
Madison Heights, MI 48071-2429
www.snowexproducts.com

 A DIVISION OF DOUGLAS DYNAMICS, LLC

Copyright © 2017 Douglas Dynamics, LLC. All rights reserved. This material may not be reproduced or copied, in whole or in part, in any printed, mechanical, electronic, film, or other distribution and storage media, without the written consent of TrynEx International, LLC. Authorization to photocopy items for internal or personal use by TrynEx International, LLC, outlets or spreader owner is granted.

TrynEx International, LLC, reserves the right under its product improvement policy to change construction or design details and furnish equipment when so altered without reference to illustrations or specifications used. TrynEx International, LLC, or the vehicle manufacturer may require or recommend optional equipment for spreaders. Do not exceed vehicle ratings with a spreader. TrynEx International, LLC, offers a limited warranty for all spreaders and accessories. See separately printed page for this important information. The following are registered (®) or unregistered (™) trademarks of Douglas Dynamics, LLC: SnowEx®, V-Maxx™.

Printed in U.S.A.
