

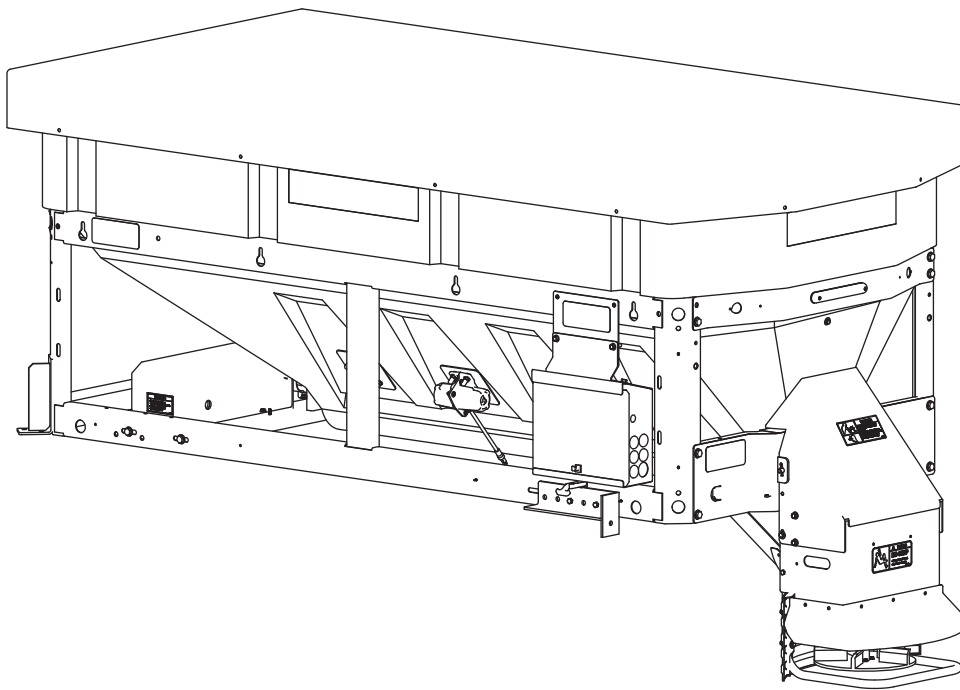

V-Maxx™ G2 Hopper Spreader VX-3200

Owner's Manual
Original Instructions



⚠ CAUTION

Read this document before operating or
servicing spreader.

TABLE OF CONTENTS

| | | | |
|--|----|---|----|
| PREFACE | 5 | Cab Control Codes | 18 |
| Owner's Information..... | 5 | Setup Procedures | 20 |
| SAFETY INFORMATION | 7 | Calibrate Empty Hopper Setting (Cb and EH Codes)..... | 20 |
| Safety Definitions..... | 7 | Adjust LED Brightness Level (LS and SL Codes)..... | 20 |
| Warning/Caution Labels | 7 | Auto-Reverse (Ar) Feature..... | 21 |
| Serial Number Label | 8 | Adjusting the Auto-Reverse (Ar) Setting | 21 |
| Safety Precautions..... | 9 | Auto-Reverse (Ar) Sequence | 21 |
| Personal Safety..... | 9 | Vibrator Function..... | 21 |
| Fire and Explosion..... | 10 | Inverted V and Discharge Baffle | 21 |
| Cell Phones..... | 10 | Baffle Extension | 21 |
| Ventilation | 10 | Spreading Tips..... | 22 |
| Battery Safety | 10 | Accessory LED Work Light..... | 22 |
| Noise..... | 10 | Dump Function..... | 22 |
| Vibration..... | 10 | REMOVING & STORING THE SPREADER | 23 |
| Torque Chart..... | 10 | Remove Hopper From Vehicle Bed | 23 |
| LOADING | 11 | Store the Spreader..... | 23 |
| Material Weights | 11 | MAINTENANCE | 24 |
| Spreader Specifications..... | 11 | Lubrication | 24 |
| Certification..... | 11 | After First Use..... | 24 |
| Load Volume..... | 12 | After Each Use..... | 24 |
| Determining Vehicle Payload | 12 | At End of Each Season or Extended Storage | 24 |
| MOUNTING THE SPREADER | 14 | Cab Control..... | 24 |
| Install Hopper in Vehicle Bed..... | 14 | Recycle | 24 |
| Install Tie-Down Ratchet Straps..... | 14 | ELECTRICAL COMPONENTS | 25 |
| INSTALLING & REMOVING THE SPINNER | | Vehicle Harness Diagram | 25 |
| ASSEMBLY | 15 | TROUBLESHOOTING GUIDE | 27 |
| Install Spinner Assembly To Hopper..... | 15 | | |
| Remove Spinner Assembly..... | 15 | | |
| OPERATING THE SPREADER | 16 | | |
| Powering the Control | 16 | | |
| Starting and Stopping Spreader | 16 | | |
| Controlling Material Application | 17 | | |
| BLAST/Maximum Application | 17 | | |
| Cab Control Modes..... | 17 | | |
| Standby Mode | 17 | | |
| Ready Mode | 17 | | |
| ON Mode | 17 | | |
| Error Mode | 17 | | |

PREFACE

This manual has been prepared to acquaint you with the safety information, operation, and maintenance of your new hopper spreader. Please read this manual carefully and follow all recommendations. This will help ensure profitable and trouble-free operation of your hopper spreader. Keep this manual accessible. It is a handy reference in case minor service is required.

When service is necessary, bring your hopper spreader to your distributor. They know your spreader best and are interested in your complete satisfaction.

NOTE: This spreader is designed to spread snow and ice control materials only. Do not use it for purposes other than those specified in this manual.

Register your spreader online at www.snowexproducts.com

OWNER'S INFORMATION

Owner's Name: _____

Date Purchased: _____

Distributor Name: _____ Phone: _____

Distributor Address: _____

Vehicle Model: _____ Year: _____

Spreader Model: _____ Serial #: _____

Spreader Weight: _____ lb/kg

SAFETY DEFINITIONS

⚠ WARNING

Indicates a potentially hazardous situation that, if not avoided, could result in death or serious personal injury.

⚠ CAUTION

Indicates a potentially hazardous situation that, if not avoided, may result in minor or moderate injury. It may also be used to alert against unsafe practices.

NOTE: Indicates a situation or action that can lead to damage to your spreader and vehicle or other property. Other useful information can also be described.

WARNING/CAUTION LABELS

Please become familiar with the Warning and Caution labels on the spreader.

NOTE: If labels are missing or cannot be read, see your sales outlet.

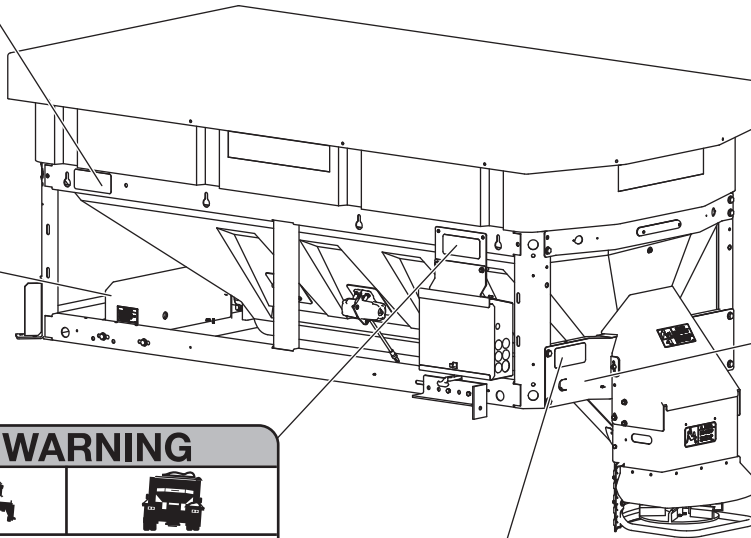
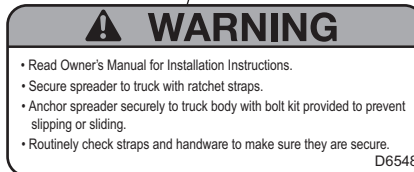
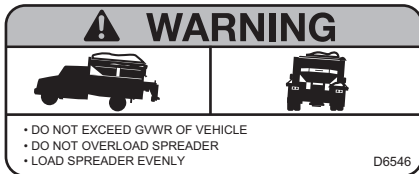
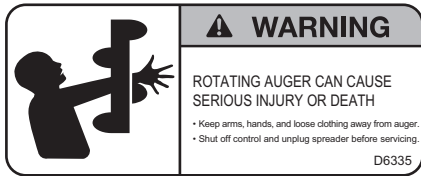

Serial Number Label (inside frame)

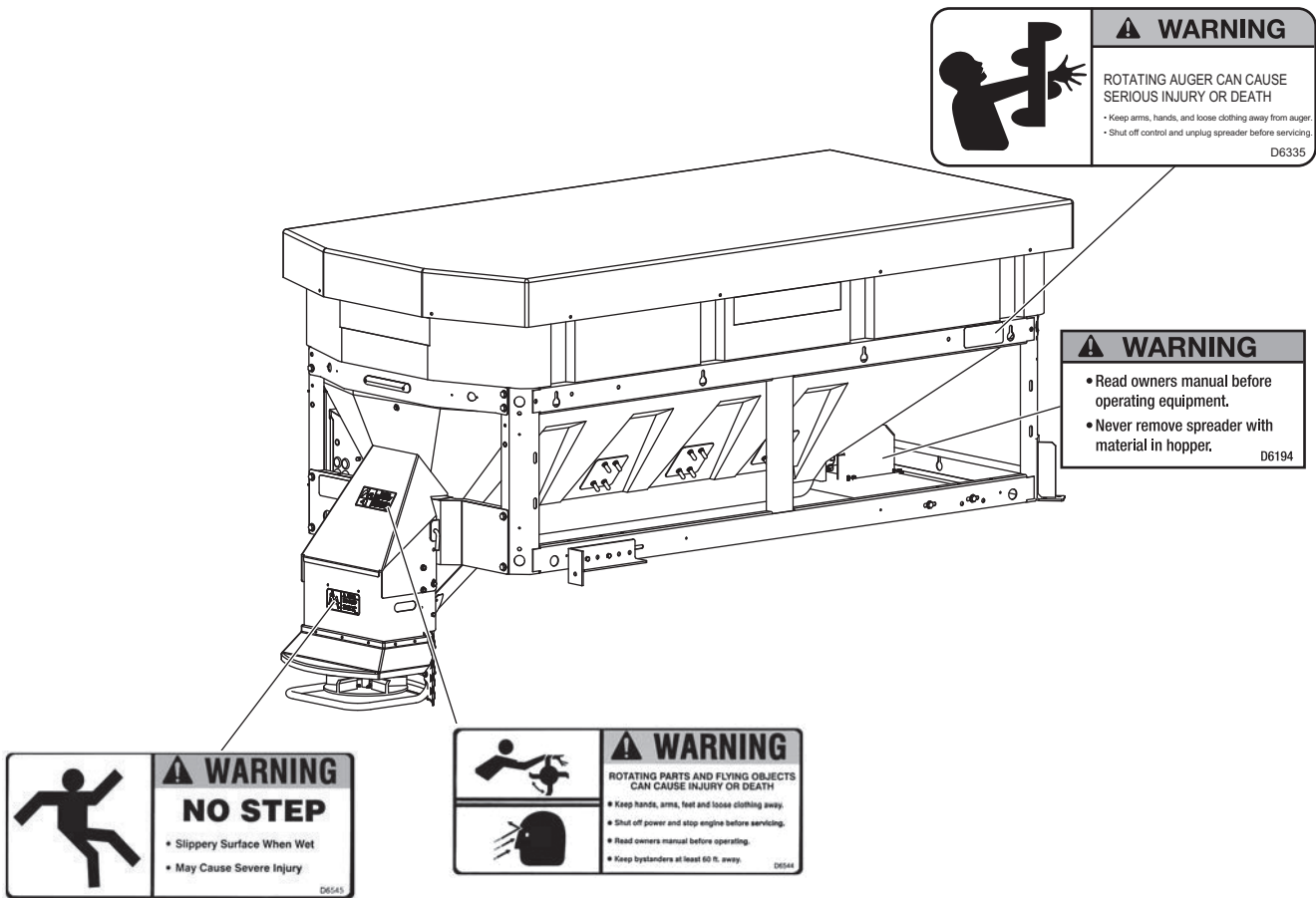

SERIAL NUMBER LABEL

SNOW EX TrynEx International, LLC
531 Ajax Drive
Madison Heights, MI 48071

VX-3200 3.2 CU YD AUGER POLY HOPPER

YYMMDDLLXXXXZZZZZ



| Code | Definition |
|-------|--------------------------------|
| YY | 2-Digit Year |
| MM | 2-Digit Month |
| DD | 2-Digit Day |
| LL | 2-Digit Location Code |
| XXXX | 4-Digit Sequential Number |
| ZZZZZ | 5-7-Digit Assembly Part Number |

SAFETY PRECAUTIONS

Improper installation and operation could cause personal injury and/or equipment and property damage. Read and understand labels and this Owner's Manual before installing, operating or making adjustments.

⚠ WARNING

- Driver to keep bystanders minimum of 25 feet away from operating spreader.
- Before working with the spreader, secure all loose-fitting clothing and unrestrained hair.
- Before operating the spreader, verify all safety guards are in place.
- Before servicing the spreader, wait for auger and spinner to stop.
- Do not climb into or ride on spreader.

⚠ WARNING



Overloading could result in an accident or damage. Do not exceed GVWR or GAWR ratings as found on the driver-side door cornerpost of the vehicle. See Loading Section to determine maximum volumes of spreading material.

⚠ WARNING

Do not install the control for this product in the deployment path of an air bag. Refer to vehicle manufacturer's manual for air bag deployment area(s).

⚠ CAUTION

If rear directional, CHMSL light or brake stoplights are obstructed by the spreader, the lights shall be relocated, or auxiliary directional or brake stoplights shall be installed.

⚠ CAUTION

During the hopper spreader installation we recommend the addition of an OSHA compliant Backup Alarm. This alarm is required for OSHA governed employers.

⚠ CAUTION

- Do not operate a spreader in need of maintenance.
- Before operating the spreader, reassemble any parts or hardware removed for cleaning or adjusting.
- Before operating the spreader, remove materials such as cleaning rags, brushes, and hand tools from the spreader.
- While operating the spreader, use auxiliary warning lights, except when prohibited by law.
- Tighten all fasteners according to the Torque Chart. Refer to Torque Chart for the recommended torque values.

⚠ CAUTION

Disconnect electric and/or hydraulic power and tag out if required before servicing or performing maintenance.

⚠ CAUTION



DO NOT leave unused material in hopper. Material can freeze or solidify, causing unit to not work properly. Empty and clean after each use.

NOTE: Lubricate grease fittings after each use. Use a good quality multipurpose grease.

PERSONAL SAFETY

- Remove ignition key and put the vehicle in park or in gear to prevent others from starting the vehicle during installation or service.
- Wear only snug-fitting clothing while working on your vehicle or spreader.
- Do not wear jewelry or a necktie, and secure long hair.
- Wear safety goggles to protect your eyes from battery acid, gasoline, dirt and dust.
- Avoid touching hot surfaces such as the engine, radiator, hoses and exhaust pipes.
- Always have a fire extinguisher rated BC handy, for flammable liquids and electrical fires.

FIRE AND EXPLOSION

WARNING

Gasoline is highly flammable and gasoline vapor is explosive. Never smoke while working on vehicle. Keep all open flames away from gasoline tank and lines. Wipe up any spilled gasoline immediately.

Be careful when using gasoline. Do not use gasoline to clean parts. Store only in approved containers away from sources of heat or flame.

CELL PHONES

A driver's first responsibility is the safe operation of the vehicle. The most important thing you can do to prevent a crash is to avoid distractions and pay attention to the road. Wait until it is safe to operate Mobile Communication Equipment such as cell phones, text messaging devices, pagers or two-way radios.

VENTILATION

WARNING

Vehicle exhaust contains lethal fumes. Breathing these fumes, even in low concentrations, can cause death. Never operate a vehicle in an enclosed area without venting exhaust to the outside.

BATTERY SAFETY

CAUTION

Batteries normally produce explosive gases which can cause personal injury. Therefore, do not allow flames, sparks or lit tobacco to come near the battery. When charging or working near a battery, always cover your face and protect your eyes, and also provide ventilation.

- Batteries contain sulfuric acid which burns skin, eyes and clothing.
- Disconnect the battery before removing or replacing any electrical components.

NOISE

Airborne noise emission during use is below 70 dB(A) for the spreader operator.









VIBRATION

Operating spreader vibration does not exceed 2.5 m/s² to the hand-arm or 0.5 m/s² to the whole body.

TORQUE CHART

CAUTION

Read instructions before assembling. Fasteners should be finger tight until instructed to tighten according to torque chart. Use standard methods and practices when attaching spreader, including proper personal protective safety equipment.

| Recommended Fastener Torque Chart | | | | | |
|--|---|--|------------|---|--|
| Inch Fasteners Grade 5 and Grade 8 | | | | | |
| Size | Torque (ft-lb) | | Size | Torque (ft-lb) | |
| |  Grade 5 |  Grade 8 | |  Grade 5 |  Grade 8 |
| 1/4-20 | 8.4 | 11.9 | 9/16-12 | 109 | 154 |
| 1/4-28 | 9.7 | 13.7 | 9/16-18 | 121 | 171 |
| 5/16-18 | 17.4 | 24.6 | 5/8-11 | 150 | 212 |
| 5/16-24 | 19.2 | 27.3 | 5/8-18 | 170 | 240 |
| 3/8-16 | 30.8 | 43.6 | 3/4-10 | 269 | 376 |
| 3/8-24 | 35.0 | 49.4 | 3/4-16 | 297 | 420 |
| 7/16-14 | 49.4 | 69.8 | 7/8-9 | 429 | 606 |
| 7/16-20 | 55.2 | 77.9 | 7/8-14 | 474 | 669 |
| 1/2-13 | 75.3 | 106.4 | 1-8 | 644 | 909 |
| 1/2-20 | 85.0 | 120.0 | 1-12 | 704 | 995 |
| Metric Fasteners Class 8.8 and 10.9 | | | | | |
| Size | Torque (ft-lb) | | Size | Torque (ft-lb) | |
| |  Class 8.8 |  Class 10.9 | |  Class 8.8 |  Class 10.9 |
| M6 x 1.00 | 7.7 | 11.1 | M20 x 2.50 | 325 | 450 |
| M8 x 1.25 | 19.5 | 26.9 | M22 x 2.50 | 428 | 613 |
| M10 x 1.50 | 38.5 | 53.3 | M24 x 3.00 | 562 | 778 |
| M12 x 1.75 | 67 | 93 | M27 x 3.00 | 796 | 1139 |
| M14 x 2.00 | 107 | 148 | M30 x 3.50 | 1117 | 1545 |
| M16 x 2.00 | 167 | 231 | M33 x 3.50 | 1468 | 2101 |
| M18 x 2.50 | 222 | 318 | M36 x 4.00 | 1952 | 2701 |
| These torque values apply to fasteners except those noted in the instructions. | | | | | |

LOADING

This Manual covers vehicles that have been recommended for carrying the hopper spreader. Please see your local dealer for proper vehicle applications.

WARNING

Overloading could result in an accident or damage. Do not exceed GVWR or GAWR as found on the driver-side cornerpost of vehicle.

MATERIAL WEIGHTS

CAUTION



Read and adhere to manufacturer's ice-control material package labeling including Material Safety Data Sheet requirements.

| Material | Density (lb/ft ³) | Density (lb/yd ³) |
|---------------------|-------------------------------|-------------------------------|
| Rock Salt – Dry | 80 | 2200 |
| Sand/Salt Mix – Dry | 100 | 2700 |

Material densities are approximate and are based on dry, loose material. It is the responsibility of the operator to know the weight of the material to be spread and the vehicle carrying capacity.

CERTIFICATION

WARNING

New untitled vehicle installation of a spreader requires National Highway Traffic Safety Administration altered vehicle certification labeling. Installer to verify that struck load of snow or ice control material does not exceed GVWR or GAWR rating label and complies with FMVSS.

SPREADER SPECIFICATIONS

| Hopper Model | Overall Length (in) | Bed Length (in) | Empty Weight (lb) | Overall Width (in) | Bed Height (in) | Capacity Struck (cu yd) |
|--------------|---------------------|-----------------|-------------------|--------------------|-----------------|-------------------------|
| VX-3200 | 108 | 100 | 939 | 54 | 43 | 3.2 |

LOADING

LOAD VOLUME

| Hopper Model | Load Volume (cu yd) | | |
|---------------------|---------------------|-----|-----|
| | A | B | C |
| VX-3200 (3.2 cu yd) | 3.8 | 3.2 | 1.5 |

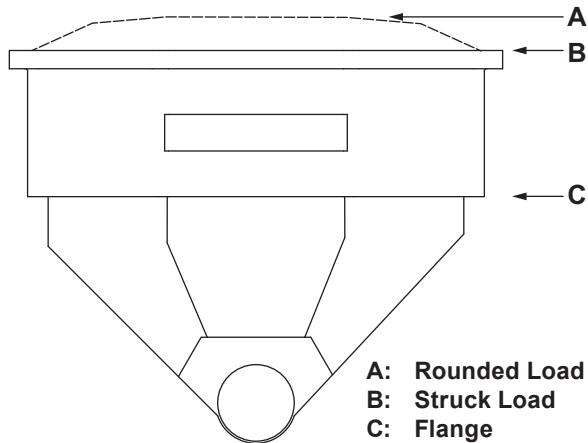

DETERMINING VEHICLE PAYLOAD

⚠ WARNING

Overloading could result in an accident or damage. Do not exceed GVWR or GAWR ratings as found on the driver-side door cornerpost of the vehicle. See Loading Section to determine maximum volumes of spreading material.

1. Install the hopper spreader and optional equipment according to the installation instructions.
2. Install or attach any other equipment that will be on the vehicle while the hopper spreader will be in use (step bumper, trailer hitch, snowplows, etc.). Fill gas tanks.
3. Obtain the Gross Vehicle Weight Rating (GVWR), Front Gross Axle Weight Rating (FGAWR), and Rear Gross Axle Weight Rating (RGAWR) from the certification label located inside the driver-side door jamb or door.
4. With the occupants in the vehicle for normal hopper spreader operation, weigh the vehicle to obtain gross vehicle weight (GVW).
5. Subtract the GVW from the GVWR to determine the available material payload.
6. Obtain the weight per cubic yard (lb/cu yd) of the desired material. Divide the weight into the payload to determine the maximum volume of material that can be carried.
7. Refer to the Load Volume table and diagrams to determine the maximum fill level for the material.
8. Fill the hopper with material to the calculated level. Reweigh the vehicle with occupants and verify that the Loaded Gross Vehicle Weight, Front Gross Axle Weight, and Rear Gross Axle Weight are less than the vehicle's ratings.
9. Repeat Steps 6–8 for each type of material.

The worksheet for Determining Vehicle Payload (next page) includes an example.

LOADING

Determining Vehicle Payload – Worksheet

| | | | | | | |
|---|--|---|--|--|--|--|
| | Material Type | <i>Example:</i> Coarse Salt – Dry | | | | |
| A | Equipment installed when vehicle was weighed | VX-3200 Spreader | | | | |
| B | Front Gross Axle Weight Rating [FGAWR] (lb) | 5600 | | | | |
| C | Rear Gross Axle Weight Rating [RGAWR] (lb) | 9900 | | | | |
| D | Gross Vehicle Weight Rating [GVWR] (lb) | 15500 | | | | |
| E | Gross Vehicle Weight [GVW], empty (lb) | – 8500 | | | | |
| F | Payload Available (lb) | = 7000 | | | | |
| G | Material Density (lb/cu yd) | ÷ 2200 | | | | |
| H | Maximum Volume (cu yd) | = 3.2 | | | | |
| I | Maximum Material Fill Level, approx. Refer to Load Volume table and diagrams. | B | | | | |
| J | Loaded Front Gross Axle Weight (lb) Must be less than weight in Row B. | | | | | |
| K | Loaded Rear Gross Axle Weight (lb) Must be less than weight in Row C. | | | | | |
| L | Loaded Gross Vehicle Weight [GVW] (lb) Must be less than weight in Row D. | | | | | |

INSTALL HOPPER IN VEHICLE BED

NOTE: Periodically throughout the snow and ice control season, verify that mounting devices are secure.

⚠ CAUTION

Before lifting, verify that the hopper is empty of material. The lifting device must be able to support the spreader's weight as shown in the spreader specifications table.

1. If the spinner assembly has been stored inside the hopper or is attached to the hopper, remove it and set aside. Remove any debris from inside the hopper.
2. Remove the vehicle tailgate or racks.
3. Lift the spreader by all four large round holes on the top of the diagonal corner rails (two shown below), using slings or chains. Move the spreader into the vehicle bed.

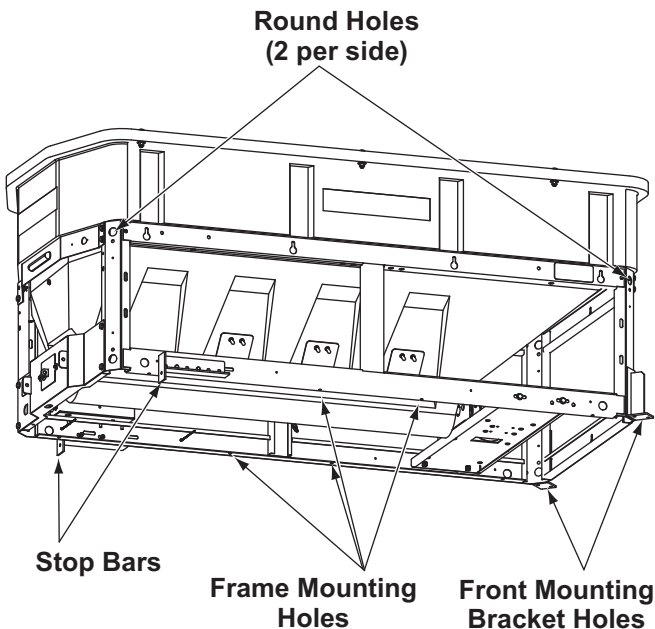

⚠ WARNING

Spreader shall be bolted to vehicle frame. Do not rely on the tie-down chains or straps alone to hold spreader in vehicle.

4. Adjust the spreader position to align the holes in the hopper frame and front mounting brackets with the mounting holes in the vehicle bed. If mounting holes are not already drilled, refer to the Hopper Spreader Installation Instructions for drilling instructions.

NOTE: Pay special attention when drilling or clamping dissimilar metals to aluminum bodies. Galvanic corrosion can occur if not handled properly. Contact vehicle manufacturer for recommended attachment practices.

5. Install the spreader to the vehicle bed using eight 1/2" cap screws down through the spreader frame and front mounting brackets. Secure with 1/2" locknuts and washers.

NOTE: If the mounting holes are not directly over the vehicle box supports, the vehicle bed must be braced to the frame to prevent buckling or deforming the vehicle bed.

6. Install the frame spacer between the end of the hopper frame and the front of the vehicle bed as shown. If you do not have a spacer, refer to the Hopper Spreader Installation Instructions for directions on building one. Failure to install this spacer could result in damage to the spreader.

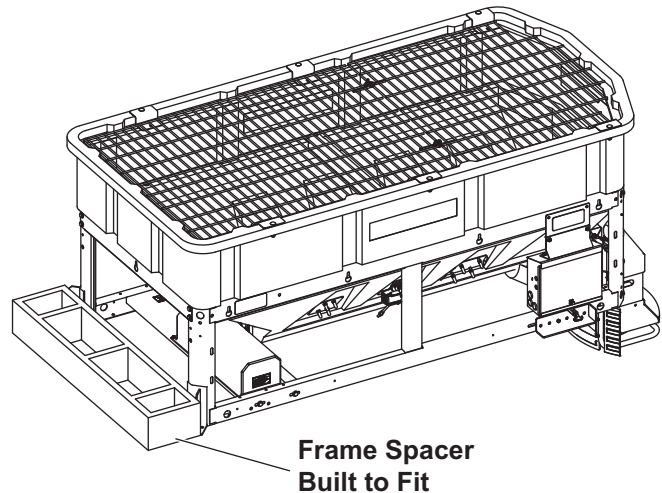

7. Connect the vehicle-side harness to the hopper-side harness.

Install Tie-Down Ratchet Straps

Install ratchet straps from the large round holes on the top of the diagonal corner rails of the spreader frame diagonally outward to the vehicle frame.

INSTALLING & REMOVING THE SPINNER ASSEMBLY

INSTALL SPINNER ASSEMBLY TO HOPPER

1. Remove the 1/4" x 20" locking pin and hairpin cotter.
2. Move the spinner assembly upward into position and set the support tabs on the rear frame.

IMPORTANT: When installing the spinner assembly on the spreader, make sure the material chute fits under the trough of the hopper.

3. Install the locking pin through the spinner assembly and the locking pin tabs on the spreader frame.
4. Connect the spinner motor plug to the spinner harness plug on the rear of the electrical control box.

REMOVE SPINNER ASSEMBLY

1. Disconnect the spinner motor plug.
2. Remove the 1/2" x 20" locking pin.
3. Remove the spinner assembly from the spreader.
4. Store the locking pin in the spinner assembly or on the spreader.

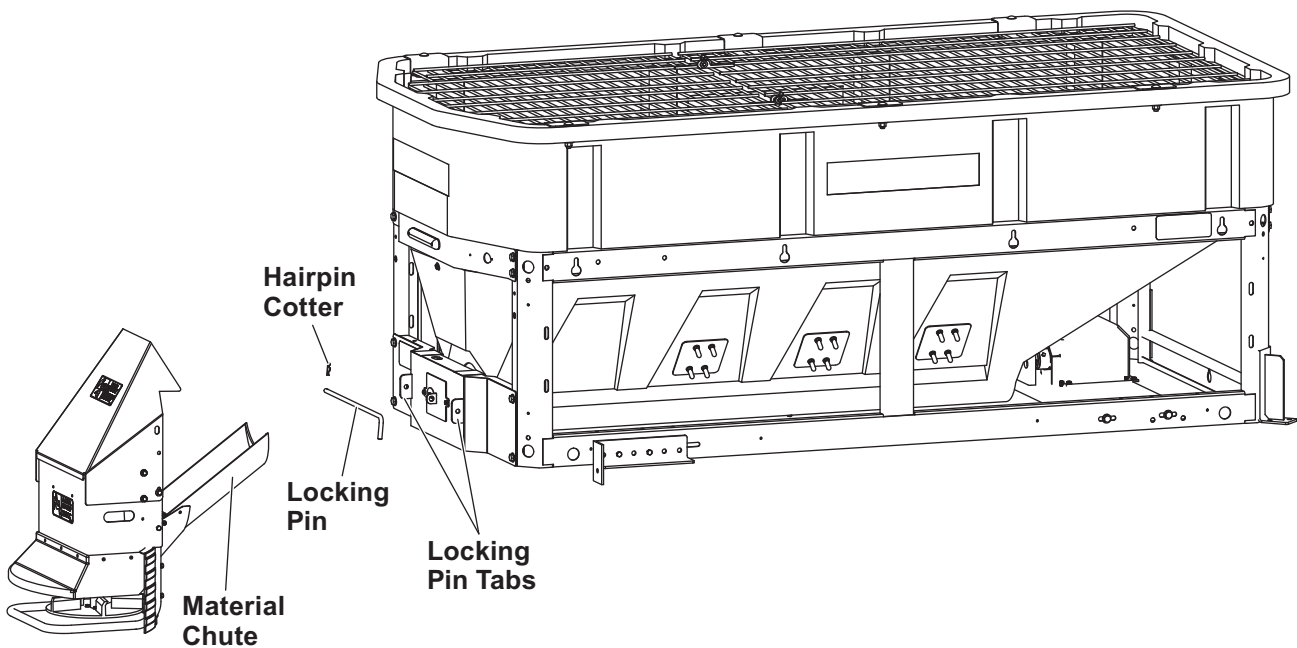

OPERATING THE SPREADER – CAB CONTROL

⚠ WARNING

Never operate equipment when under the influence of alcohol, drugs, or medications that might alter your judgment and/or reaction time.

⚠ WARNING

Never exceed 45 mph (72 km/h) when loaded spreader is attached to vehicle. Braking distances may be increased and handling characteristics may be impaired at speeds above 45 mph (72 km/h).

⚠ WARNING

Never allow children to operate or climb on equipment.

If any button is pressed on the control, it will wake and check again for spreader connection. If no spreader is detected, it will act as previously described. If a spreader is detected, it will transition to Ready Mode.

STARTING AND STOPPING SPREADER

⚠ WARNING

Before starting the spreader, the driver shall verify that all bystanders are a minimum of 25 feet away from operating spreader.

To start the spreader, press the ON/OFF button. The control backlights are illuminated when the vehicle ignition is ON and the spreader is connected. When the spreader is ON, the ON/OFF button and inner arc around each control knob will also illuminate.

To stop the spreader, press the ON/OFF button again.

The ON/OFF button also operates as an emergency stop when required.

POWERING THE CONTROL

Power is not applied to the control until the vehicle ignition is turned to ACC or ON. Once the control has power it performs a light check and displays the software version on the status display. The control then checks for a connected spreader. If no spreader is detected, the control does the following:

- **nC** (no connection) appears on the red status display for five seconds;
- A single beep;
- Control enters Standby mode with no lights illuminated.

NOTE: The vehicle ignition must be ON to start the spreader.

NOTE: If vehicle ignition is turned OFF while spreader is running, the motors will stop.

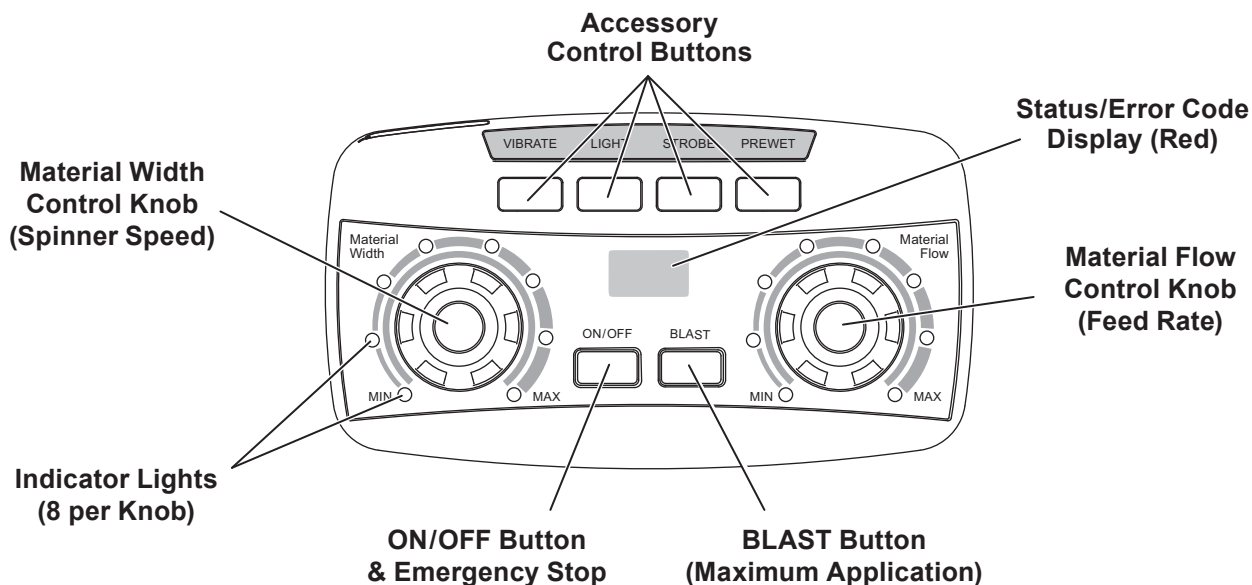

OPERATING THE SPREADER – CAB CONTROL

CONTROLLING MATERIAL APPLICATION

The material application settings can be adjusted while spreader is ON or OFF. Settings are shown by the indicator lights around the control knobs. When the spreader is OFF, a single LED will light to show the current setting. When the spreader is ON, the number of blue LEDs illuminated will increase/decrease as the knobs are turned clockwise/counterclockwise.

The hopper drive will not deliver material until the ON button is pressed.

The Material Width (left) knob controls spinner speed. Turning the knob clockwise will increase the width of the application area.

The Material Flow (right) knob controls the hopper drive. Turning the knob clockwise will increase the feed rate of material to the spinner.

Turning the control knobs counterclockwise will decrease the width of the application area and the feed rate of material.

BLAST/Maximum Application

1. Press and hold the BLAST button when maximum flow rate and application area are needed temporarily. The BLAST button will illuminate while depressed.
2. Release the button when maximum application settings are no longer needed.

NOTE: Spinner speed and material feed rate revert to the previous settings once the BLAST button is released.

CAB CONTROL MODES

Standby Mode

Vehicle ignition is set to ACC or ON; cab control is OFF. Control has power. No spreader was detected. No lights are illuminated on the control. Press any button to wake.

Ready Mode

Vehicle ignition is set to ACC or ON; cab control is OFF. Control has power. Spreader is detected.

The Material Width and Material Flow control knobs can be set to start-up conditions, but the spinner and drives will not operate until the cab control is turned ON.

Accessory lights and vibrator are operational. The BLAST function is not operational.

ON Mode

Vehicle ignition is set to ACC or ON; cab control is ON.

Spinner and hopper motors will start. All cab control functions are operational. Accessory lights and vibrator are operational.

During normal spreader operation, **no control codes are displayed**. Information or setup codes will appear when relevant. These codes will not stop spreader operation.

Error Mode

When an error condition occurs, spreader operation will shut down. A two-digit error code will flash on the display and a beep will sound. If there are multiple error codes, the codes will flash in a repeating sequence.

Refer to the Error Codes portion of the following Cab Control Codes table. Also see the Troubleshooting Guide section of this manual.

Once the error condition has been resolved, press the ON/OFF button to clear the error code(s). Press the ON/OFF button again to resume spreader operation.

The error code will reappear if the error condition has not been rectified. If the error condition persists, contact your authorized dealer.

Multiple resets within a short time frame will cause the hopper module to time out if components are overheating. The control will display an **EF** error code.

Accessory work lights and strobe lights can be used when an error code is in effect and will remain in their current state. The vibrator and pre-wet will not function.

OPERATING THE SPREADER – CAB CONTROL

CAB CONTROL CODES

| Setup Codes | | |
|-------------|---|--|
| Code | Definition | Procedure |
| Cb | Calibrate the Empty Hopper setting. | With control in ON mode, press and hold the left control knob until the Cb code displays. Calibration cycle is automatic.* |
| Cc | Clear calibration data for Empty Hopper setting; clear EH code. | Press the right control knob to clear all calibration data during the calibration cycle. |
| LS | Set LED brightness level. | With control in Ready mode, press and hold left control knob to get LS code. Release pressure and turn left control knob to desired brightness setting. Wait for confirming SL code to display.* |
| SL | Confirms that LED brightness level has been reset. | |

* For full instructions, see the "Setup Procedures" section.

| Information Codes | | |
|-------------------|--|--|
| Code | Definition | Response |
| Ar | Auto-reverse sequence is active. | The spreader will automatically detect and attempt to clear a jam. See the "Operating the Spreader" section of this manual. |
| dU | Spreader is in dump mode: <ul style="list-style-type: none"> • Spinner assembly is removed. • Back Dump buttons are enabled. | To operate the dump function, see instructions in the "Operating the Spreader" section of this manual. If dU code displays when the spinner assembly harness is attached, contact authorized dealer. |
| EH | Empty hopper (beep will sound). | Check hopper for material. Recalibrate Empty Hopper setting as described above for Cb code. |
| Lb | Low battery. Hopper module is sensing < 10V. (Lb becomes an error code when module senses < 6V.) | Refer to the Lb row under "Error Codes" (next table). |

| Error Codes – Spreader Operation Stopped | | | |
|--|---------------------------------------|---|--|
| Code | Definition | Possible Cause | Suggested Solution |
| bb | Bad button | Button is stuck. Button was pressed while vehicle ignition was entering ACC or START mode. | Inspect control. Free up button. Do not press any spreader cab control buttons while the vehicle ignition is being engaged. |
| bH | Bad hopper | Possible module or control mismatch. | Replace control or module. Use only genuine service parts. Contact authorized dealer. |
| CE | No communication with spreader module | Loose connection. Module lost power. Disconnected spreader harness while vehicle is on. | Confirm that spreader and control harnesses are connected to the vehicle harness. Check power to spreader module, all connections, fuses and power studs. Check that B port is plugged in. |
| CP | Spinner assembly present fault | Spinner assembly harness is not attached. | Install the spinner assembly harness. Reset the control by pressing the ON/OFF button. |
| Ct | Control is hot. | Cab temperature is too high. Control overheated. | Turn off spreader and allow control to cool off. |
| EF | Excessive drive faults | Too many HO and/or SO error codes; hopper module overheating. | Control times out for 60 seconds. Ensure the auger and/or spinner are not jammed. |

Table continues on next page.

OPERATING THE SPREADER – CAB CONTROL

CAB CONTROL CODES *continued*

| Error Codes – Spreader Operation Stopped | | | |
|--|---|--|---|
| Code | Definition | Possible Cause | Suggested Solution |
| HO | Hopper overload – software trip | Drive system has high current. Material is jammed. | Inspect auger; clear material jam or fix auger as needed. |
| HO. | Hopper overload – hardware trip | Auger is damaged. | |
| HP | Hopper power issue. No motor present. | Hopper drive motor is not connected. Possible motor defect. | Check connections to the auger drive motor (P—FEED and FEED—N posts on the module and studs on the motor). Replace the motor. |
| Lb | Low battery. Hopper module is sensing $\leq 6V$. | Bad connection or low battery. Snowplow or other vehicle power use may be driving down voltage. | Voltage is measured at the hopper module, so Lb code may indicate cable voltage loss. Check battery, alternator and connections. |
| nC | No connection. | Spreader not connected to vehicle harness. | Connect vehicle and spreader harness. Check vehicle harness fuse. Inspect spreader and vehicle harnesses. Check module. |
| OH | Overheating | Spreader module is too hot. Spreader module malfunction. | Allow a cool-off period of 60 seconds or longer. Check for loose harness connections. Check accessory connections. Check integrity of accessory wiring and harness. Clear jammed material. Contact authorized dealer. |
| OH. | Overheating module – microprocessor | Accessories wiring/function problem. Drive motor overload. | |
| rS | Reset of spreader module | Power loss to module detected on startup. | Reset the control by pressing the ON/OFF button. Check vehicle harness and battery connection. |
| SO | Spinner drive overload – software trip | Material jammed in spinner. Spinner shaft is damaged. | Inspect spinner and spinner drive components for alignment and condition. |
| SO. | Spinner drive overload – hardware trip | | |
| SP | Spinner power issue. No motor present. | Spinner drive motor is not connected. Possible motor defect. | Check connections to the motor (SPIN and GND posts on the module). Replace the motor. |

OPERATING THE SPREADER – CAB CONTROL

SETUP PROCEDURES

Calibrate Empty Hopper Setting (Cb and EH Codes)

Calibrating the empty hopper setting enables the cab control to alert the operator when the hopper is empty.

Recalibrate the empty hopper setting at the start of each ice-control season.

1. Verify the hopper is empty before beginning the calibration.
2. Turn the vehicle ignition to ACC or ON. Press the ON/OFF button on the cab control to turn the control ON.
3. Press and hold the Material Width (left) knob for approximately 10 seconds until the **Cb** code displays.
4. The calibration cycle will begin. The blue LEDs around the Material Flow (right) knob will illuminate in succession until all 8 are lit.
5. When the automatic calibration cycle is complete, the control will automatically revert to the previous material application settings.

If the control is turned OFF or loses power during the calibration cycle, the calibration data will be lost. Make sure the control is ON and restart the calibration process at Step 3.

After the empty hopper setting has been calibrated, the **EH** code will flash on the display and a beep will sound whenever the hopper is empty. The **EH** code is informational only and will not stop spreader operation.

Clearing Empty Hopper Calibration Data (Cc Code)

The empty hopper calibration may be cleared, if desired. The control will no longer display the **EH** status code when the hopper is empty.

Start the calibration cycle as described above. At Step 4, press the Material Flow (right) knob during the calibration cycle to clear *all* calibration data. The **Cc** (Clear Calibration) code will display and the control will exit **Cc** mode automatically.

Adjust LED Brightness Level (LS and SL Codes)

The brightness setting of the cab control lights can be adjusted from 1 to 16. The factory default setting is 8.

1. Turn the vehicle ignition to ACC or ON. If necessary, press the cab control ON/OFF button to turn the control OFF.
2. Press and hold the Material Width (left) knob for approximately 3 seconds until the **LS** code is displayed.
3. Release the knob and turn it clockwise or counterclockwise to increase/decrease the brightness level. The light level number will show in the status display.
4. After selecting the desired brightness level, wait a few seconds for the **SL** confirmation code to display.

NOTE: A brightness level setting of 12 or higher is recommended for daylight conditions.

AUTO-REVERSE (Ar) FEATURE

The spreader is automatically able to sense and clear material jams. The sensitivity level of the auto-reverse feature is adjustable.

Adjusting the Auto-Reverse (Ar) Setting

1. With the spreader connected and the control powered up in the READY mode, press and hold the BLAST button. After 5 seconds, a number will appear on the status display (factory default is 20).
2. Continue to hold the BLAST button and turn the right-hand knob to control the material flow setting (range is 2-30). Turn the knob clockwise to increase the flow. Turn the knob counterclockwise to decrease the flow.
3. Release the BLAST button.
4. Press the ON/OFF button twice (turning the spreader ON, then OFF) to save the setting.
5. If auto-reverse is too sensitive or not sensitive enough, repeat the Steps 1-4 and adjust the value. If the value is set to 30, the auto-reverse feature will be disabled.

Auto-Reverse (Ar) Sequence

The **Ar** sequence will begin automatically, and consist of a series of reverse-then-forward movements of the auger.

The **Ar** sequence will make up to five attempts to clear the jam. The status display will flash **Ar** then a number, and repeat as it counts down from 5 to 1. If the jam is cleared, the auger will automatically return to normal operation at the previous control settings.

⚠ CAUTION

Disconnect electric power and tag out, if required, before servicing or performing maintenance.

If auto-reverse is unsuccessful, then the operator must extract the material that is causing the problem. Follow all warning directions when clearing jams.

VIBRATOR FUNCTION

A heavy-duty vibrator is standard equipment on the model VX-3200 spreaders. Turn the vibrator ON as needed to keep dense material flowing and prevent bridging of material in the hopper.

A second vibrator can be added. Accessory vibrator kits are available through your authorized dealer.

CONTROLLING THE FLOW OF MATERIAL

Inverted V and Discharge Baffle

The V-Maxx™ VX-3200 uses an inverted V baffle design over the auger area. This baffle is used to reduce the load to the auger drive train. It must not be removed unless servicing the unit.

This spreader also uses a discharge baffle to reduce material leakage. Do not remove the discharge baffle unless servicing the unit.

Inverted V Baffle

The inverted V baffle fits over the inverted V and is intended to be used with very dry products that free-flow with little effort. The baffle is designed to keep these types of materials from leaking out.

- If using damp/wet materials, or a sand/salt mixture, remove this baffle by removing the retaining nut.

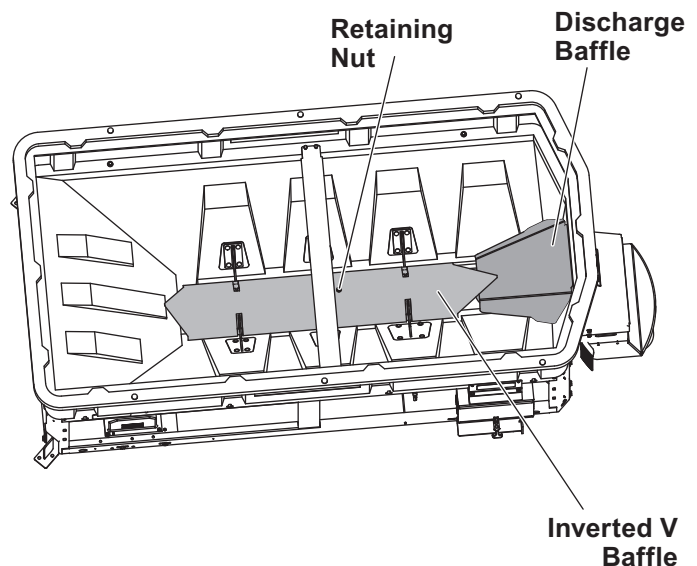

SPREADING TIPS

- Spread ice melters with the storm to prevent unmanageable levels of ice.
- Never exceed 10 mph (16 km/h) when spreading.
- For a wider pass, increase spinner speed.
- For a heavier pass, drive slower or increase auger speed.
- Never operate spreader near pedestrians.
- Calculate spread pattern when near vegetation.

NOTE: The spinner motor is not designed for continuous duty. Allow the motor to cool between long cycle times.

ACCESSORY LED WORK LIGHT

V-Maxx™ spreaders are equipped with a button to operate an accessory work light. The button is on the driver's side of the power box on the chute end of the hopper. The work light can also be turned on and off from the cab control.

A second LED light and harness can be also be added. Accessory work light kits are available through your authorized dealer.

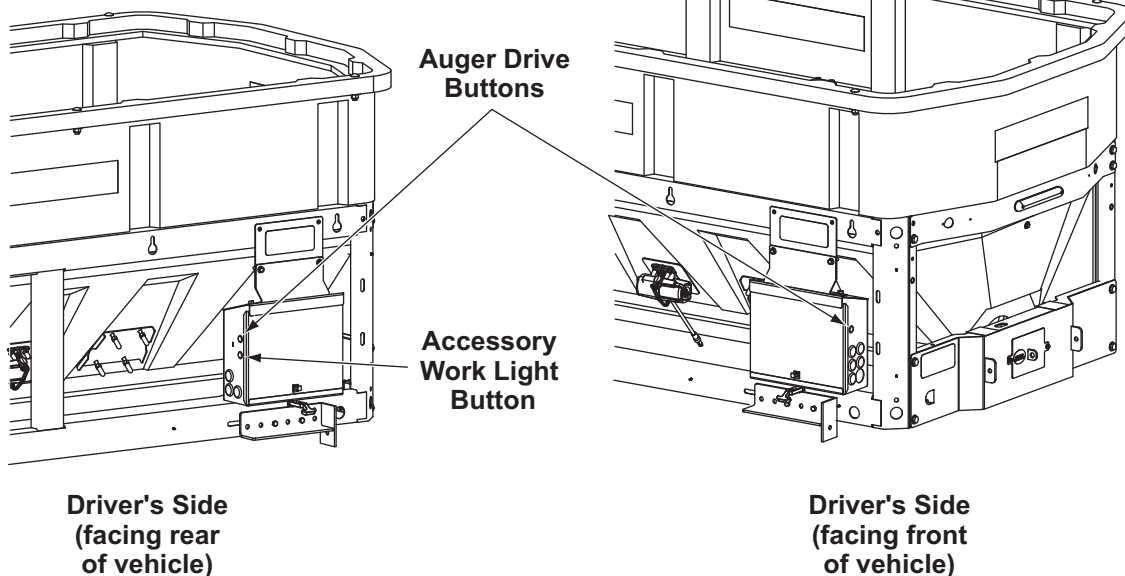

DUMP FUNCTION

The dump function allows the operator to activate the auger to empty the hopper after use or load material into a walk-behind spreader.

The dump function is a two-handed operation requiring the operator to press two buttons at the same time. The auger drive buttons are located on opposite sides of the power box/accessory hub on the rear end of the hopper. The spinner motor harness must be disconnected to enable the dump function.

1. Disconnect the spinner motor harness. If necessary, the spinner assembly may be removed. See "Remove Spinner Assembly" on page 15.
2. Position the material receptacle or walk-behind spreader under the end of the hopper.
3. Standing to one side of the auger exit, press and hold both auger drive buttons to operate the auger.

NOTE: Do not stand directly in front of the auger when operating the dump function.

4. To stop the auger, release one or both of the buttons.

REMOVING & STORING THE SPREADER

REMOVE HOPPER FROM VEHICLE BED

1. Remove the spinner assembly from the hopper body and set it aside. For instructions on how to remove the spinner assembly, see "Remove Spinner Assembly" on page 15.
2. Disconnect the vehicle-side harness from the hopper-side harness.
3. Remove the frame spacer from the end of the hopper frame and set it aside.

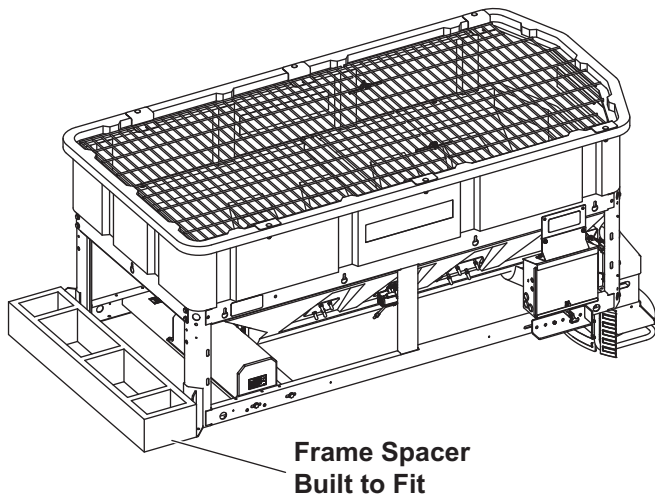

4. Remove the mounting hardware from the frame mounting holes and the tie-downs straps from the frame corners.

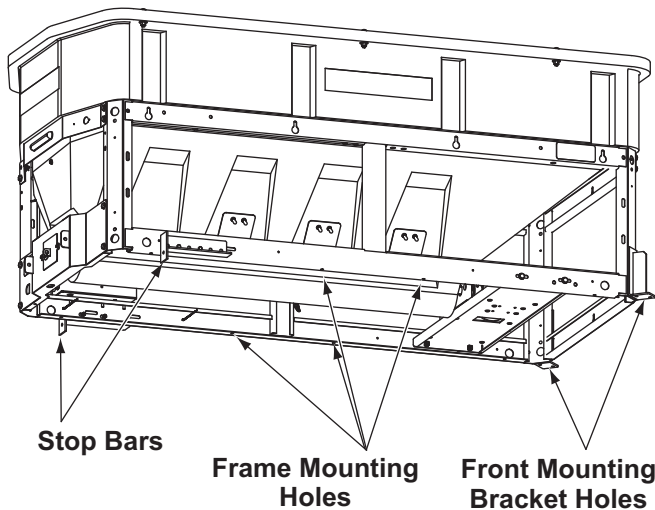

⚠ CAUTION

Before lifting, verify that the hopper is empty of material. The lifting device must be able to support the spreader's weight as shown in the spreader specifications table.

5. Attach slings or chains to the four large round holes on the top of the diagonal corner rails, and lift the spreader from the vehicle bed.

STORE THE SPREADER

The spreader can be stored in truck position on blocks or stands. Make sure the supports are stable and the ground beneath is firm enough that the spreader will not shift over time.

1. Move the spreader to the storage location using a hoist, or lower it onto blocks and use a forklift to move it to a secure location.
2. The hopper body should be slightly tilted toward the rear end to prevent any rainwater from pooling in the hopper.
3. Use blocking to ensure that the spreader is stable.
4. If desired, store the spinner assembly inside or on top of the hopper.

MAINTENANCE

⚠ WARNING

Never remove the spreader with material in the hopper.

⚠ CAUTION

Disconnect electric power at spreader electrical wiring harness connection and tag out if required before servicing or performing maintenance.

LUBRICATION

To keep your spreader running smoothly, lubricate the grease fittings (as shown below) after each use and at the end of each season.

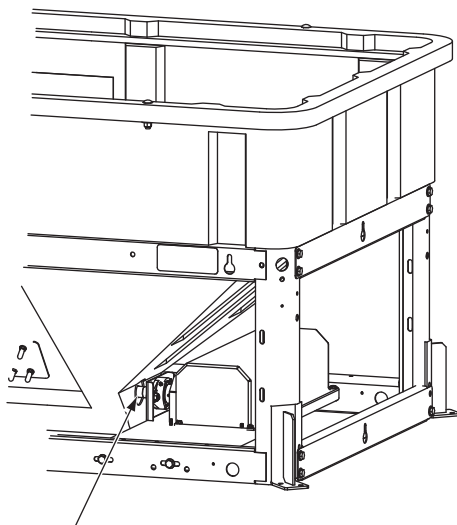
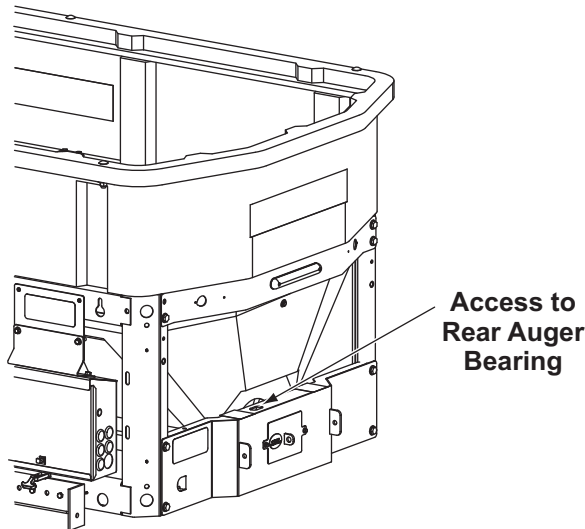

AFTER FIRST USE

Tighten all mounting fasteners.

AFTER EACH USE

- Wash unit after each use to prevent material build-up and corrosion.

NOTE: Do not spray water directly on the auger bearing and seals.

⚠ CAUTION



DO NOT leave unused material in hopper. Material can freeze or solidify, causing unit to not work properly. Empty and clean after each use.

- Apply dielectric grease on all electrical connections to prevent corrosion.

AT END OF EACH SEASON OR EXTENDED STORAGE

- Apply dielectric grease on all electrical connections to prevent corrosion at the beginning and end of the season and each time the power plugs are disconnected.
- Wash out the hopper and rinse off all external surfaces to prevent material build-up and corrosion.
- Paint or oil all bare metal surfaces at the end of the season.
- Apply a small amount of light oil to latches as needed.

CAB CONTROL

Unplug the cab control from the control harness at the end of the season or when the hopper is removed from the vehicle.

RECYCLE

When your spreader has performed its useful life, many of its components can be recycled.

VEHICLE HARNESS DIAGRAM

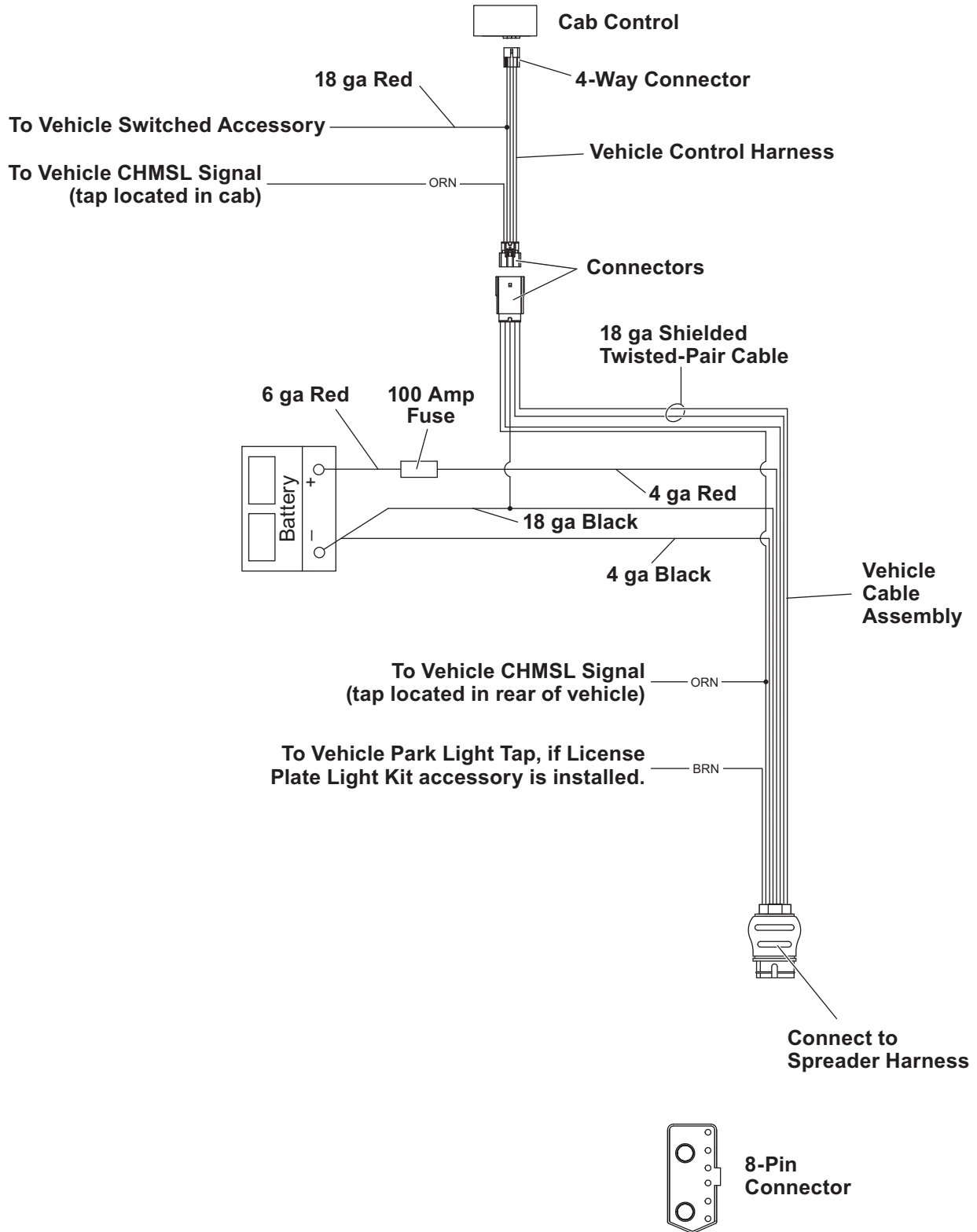

www.storksplows.com
ELECTRICAL COMPONENTS

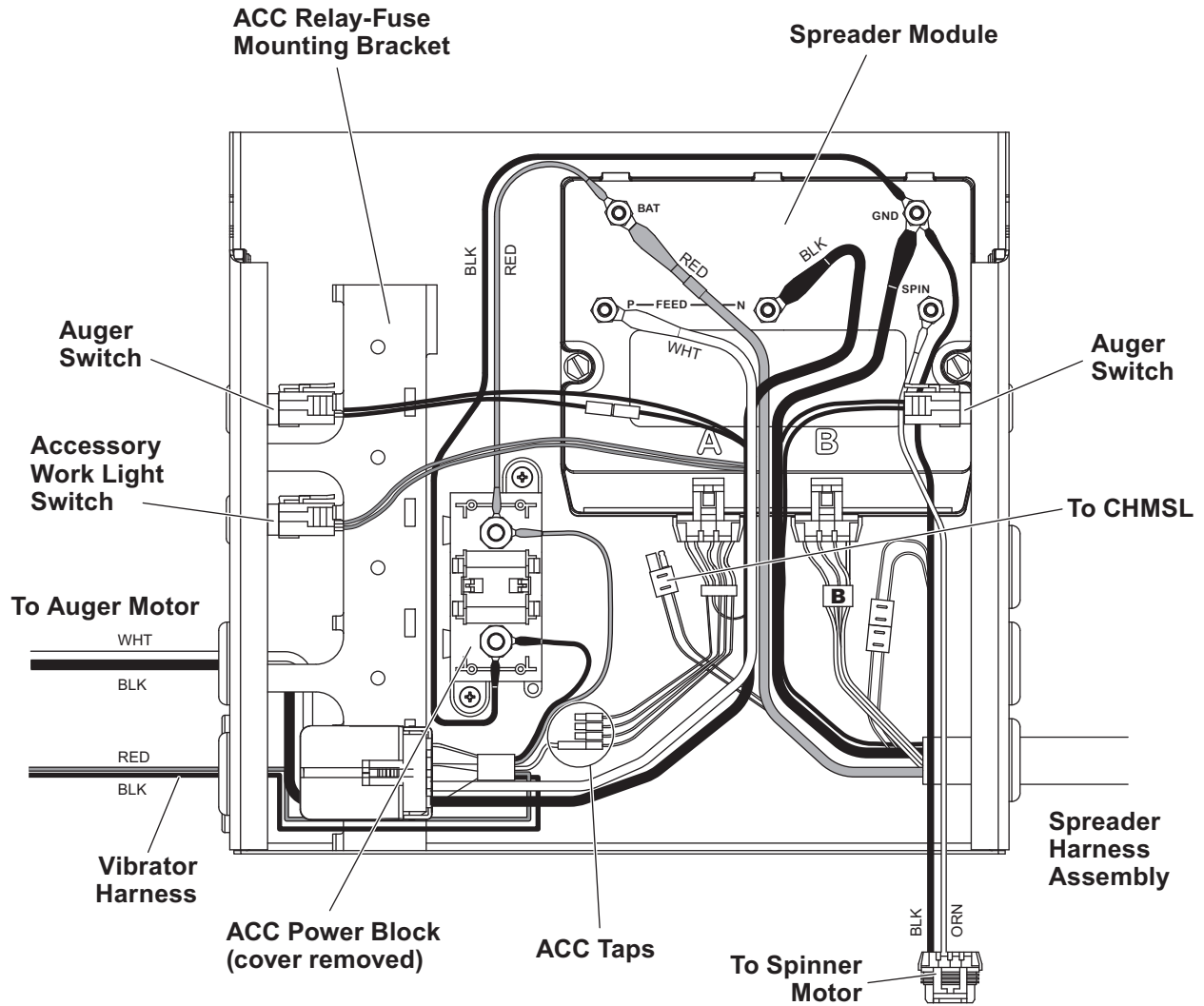

www.storksplows.com
TROUBLESHOOTING GUIDE

Please see your authorized dealer for service. The troubleshooting reference table below may guide you in diagnosing the issue.

For a reference table of the cab control error codes, see the "Operating the Spreader – Cab Control" section of this manual.

Before servicing the spreader:

- Review all safety information.
- Confirm that all electrical connections are tight and clean.
- Confirm that nothing is jammed in the hopper.

| Problem | Possible Cause | Suggested Solution |
|---|---|--|
| No power to cab control. Ignition and control switches ON; control knob indicator lights not illuminated. | 1. Control is in Standby mode. Spreader is not connected. | 1. Press any button on control to wake. |
| | 2. Control connector plug is loose. | 2. Check plug connection at cab control. |
| | 3. Switched accessory connection is poor or faulty battery. | 3a. Check for low battery. 3b. Check switched accessory connection. |
| | 4. Blown fuse. | 4. Replace spreader vehicle battery cable fuse. |
| | 5. Vehicle control harness is damaged. | 5. Repair or replace damaged wires or harness as required. |
| Turning control knobs does not change motor speed. | 1. Malfunctioning cab control. | 1. Replace cab control. |
| | 2. Malfunctioning spreader module. | 2. Replace spreader module. |
| Spreader does not operate. | 1. Overloaded condition is causing over-current protection to activate. | 1. Reset cab control by pressing the ON/OFF switch. |
| | 2. Wire harness is damaged or has an open circuit between cab control and spreader. | 2a. Check plug connections at cab control and spreader. 2b. Check wire connections at spreader motor and at vehicle battery: disconnect motor leads, turn Material Width and Material Flow knobs to maximum, and check for voltage at motor leads. 2c. Repair or replace damaged wires and connectors. 2d. Check the 100 A in-line fuse on the 22" red cable. Replace if necessary. |



 A DIVISION OF DOUGLAS DYNAMICS, LLC

Copyright © 2017 Douglas Dynamics, LLC. All rights reserved. This material may not be reproduced or copied, in whole or in part, in any printed, mechanical, electronic, film or other distribution and storage media, without the written consent of TrynEx International. Authorization to photocopy items for internal or personal use by TrynEx International outlets or spreader owner is granted.

TrynEx International reserves the right under its product improvement policy to change construction or design details and furnish equipment when so altered without reference to illustrations or specifications used. TrynEx International or the vehicle manufacturer may require or recommend optional equipment for spreaders. Do not exceed vehicle ratings with a spreader. This product is manufactured under the following U.S. patents: 7,400,058; 7,737,576, and other patents pending. TrynEx International offers a limited warranty for all spreaders and accessories. See separately printed page for this important information. The following are registered (®) or unregistered (™) trademarks of Douglas Dynamics, LLC: SnowEx®, TrynEx®, V-Maxx™.

Printed in U.S.A.