

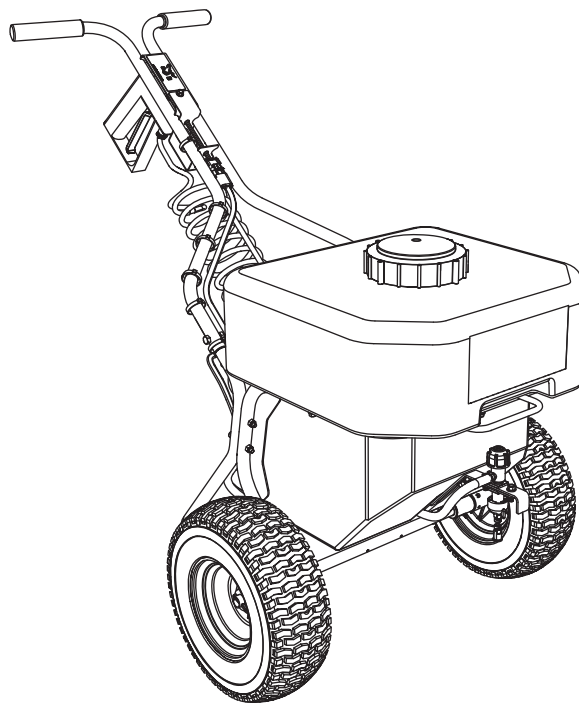

Walk-Behind Sprayer

SS-120

Parts List



This manual is for WESTERN® walk-behind sprayers with serial numbers beginning with 170301 and higher.

HANDLE ASSEMBLY

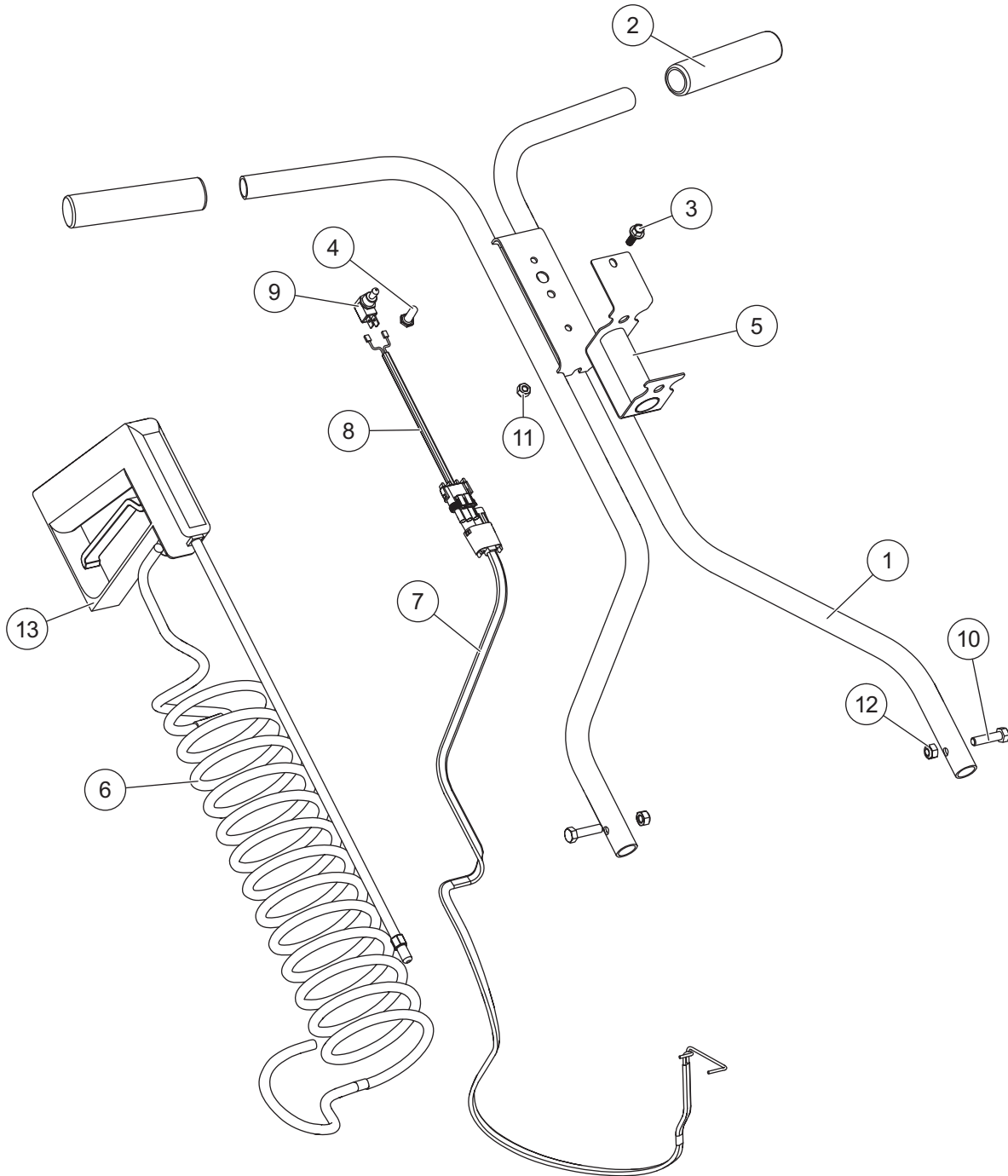

www.storksplows.com
SS-120 WALK-BEHIND SPRAYER

Handle Assembly Components							
Item	Part	Qty	Description	Item	Part	Qty	Description
1	50912	1	Handle	7	11252	1	Pump Harness
2	50917	2	Handle Grip	8	11253	1	Switch Harness
3	51031	1	1/4-20 x 3/4 Serrated Flange Hex Cap Screw SS	9	11254	1	Switch
4	11236	1	Rubber Switch Boot	10	11257	2	5/16-18 x 1-1/4 Hex Cap Screw SS
5	11239	1	Wand Bracket	11	50970	1	1/4-20 Locknut SS
6	11246	1	Coil Hose	12	50971	2	5/16-18 Locknut SS
				13	11261	1	Spot Spray Wand
SS = Stainless Steel							

TANK ASSEMBLY

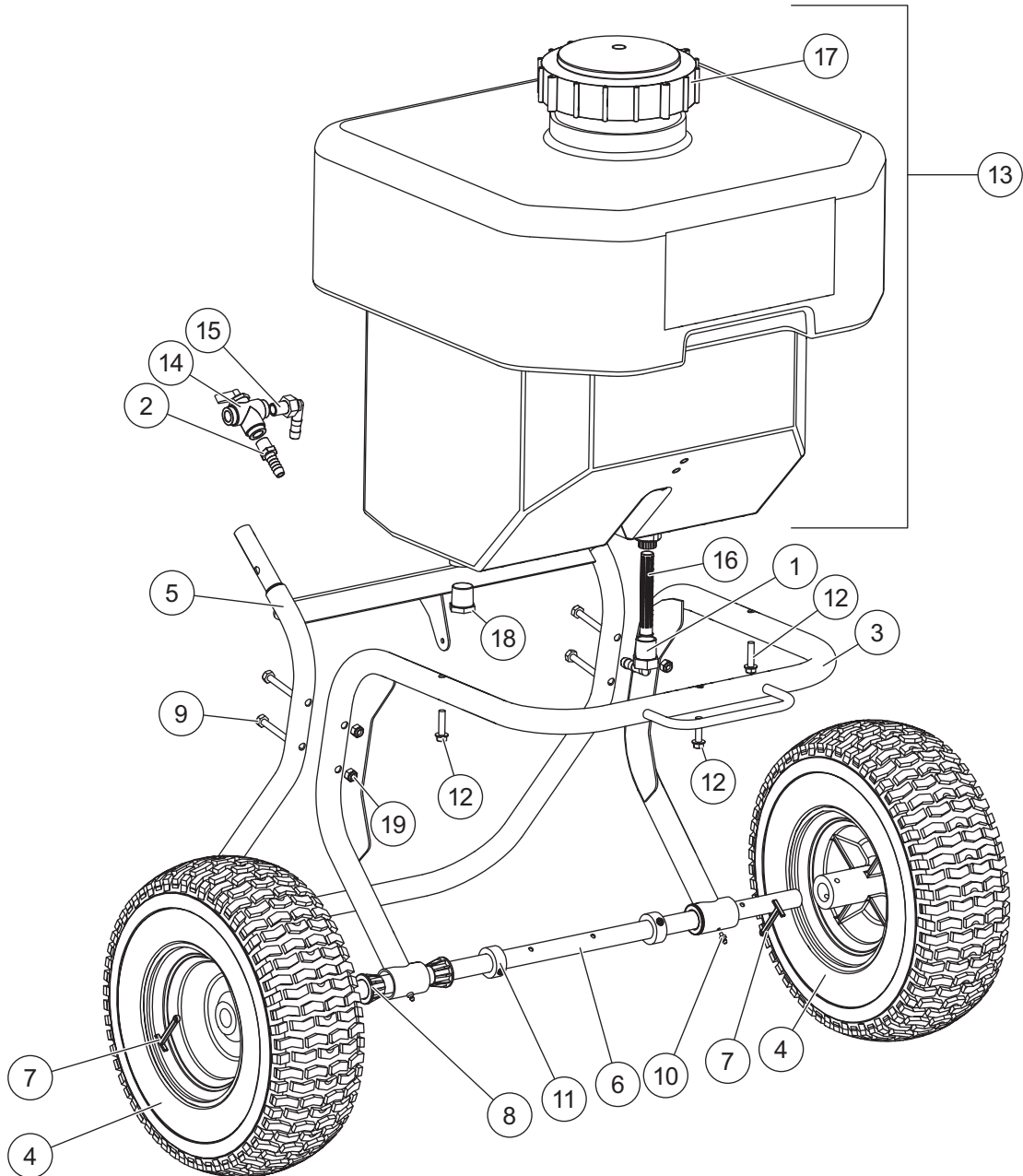

www.storksplows.com
SS-120 WALK-BEHIND SPRAYER

Tank Assembly Components							
Item	Part	Qty	Description	Item	Part	Qty	Description
1	11233	1	1/2 Male Thread x 3/8 90° Hose Barb	11	50965	2	Shaft Collar
2	11234	1	1/4 Male Thread x 3/8 Hose Barb	12	11237	3	1/4-20 x 1 Serrated Flange Hex Cap Screw SS
3	11235	1	Hopper Frame				
4	50907	2	13 x 5 Wheel	13	11150	1	Tank (incl. item 17)
5	50909	1	Frame Stand	14	11247	1	Panel Mount Valve
6	50915	1	Axle	15	11249	1	1/4 Male Thread x 3/8 90° Hose Barb
7	50933	2	2" Cotter Pin SS	16	11255	1	Tank Strainer
8	50935	4	Wheel Bushing	17	11259	1	Tank Lid, 6" Vented
9	50948	4	1/4-20 x 2-1/4 Hex Cap Screw SS	18	11260	1	1/2 Pipe Plug
10	50964	2	Grease Fitting	19	50970	4	1/4-20 Locknut SS
SS = Stainless Steel							

www.storksplows.com
SS-120 WALK-BEHIND SPRAYER

Motor Assembly Components							
Item	Part	Qty	Description	Item	Part	Qty	Description
1	11233	1	1/2 Male Thread x 3/8 90° Hose Barb	10	11241	1	Hose Guide
2	51030	11	1/4-20 x 1/2 Serrated Flange Hex Cap Screw SS	11	11242	1	Pump Enclosure
3	51031	2	1/4-20 x 3/4 Serrated Flange Hex Cap Screw SS	12	11243	1	Pump
4	51039	4	#10-32 x 5/8 Serrated Flange Hex Cap Screw w/Patch	13	11244	1	Pump Enclosure Cover
5	10823	1	Hose, 3/8 x 16-1/2	14	11245	1	Inside Nozzle Body Bracket
6	10823	1	Hose, 3/8 x 30	15	11248	1	Outside Nozzle Body Bracket
7	10823	1	Hose, 3/8 x 40	16	11250	1	Push Sprayer Nozzle
8	11238	1	Battery Bracket	17	11251	1	Nozzle Body
9	11240	1	Battery	18	11256	3	Rubber Grommet
				19	11258	6	3/8 Hose Clamp
				20	11260	1	1/2 Pipe Plug
				21	50970	2	1/4-20 Locknut SS

SS = Stainless Steel

ELECTRICAL ACCESSORY

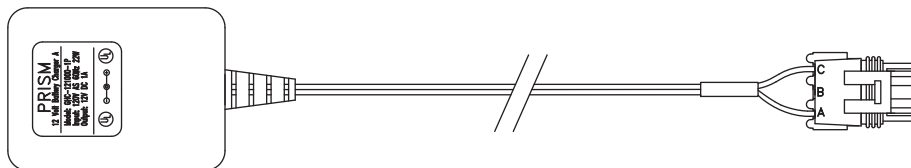

Electrical Accessory		
Part	Qty	Description
11145	1	Battery Charger, 110V AC/12V DC

www.storksplows.com
SS-120 WALK-BEHIND SPRAYER



Western Products
PO Box 245038
Milwaukee, WI 53224-9538
www.westernplows.com

 A DIVISION OF DOUGLAS DYNAMICS, LLC

Copyright © 2019 Douglas Dynamics, LLC. All rights reserved. This material may not be reproduced or copied, in whole or in part, in any printed, mechanical, electronic, film or other distribution and storage media, without the written consent of Western Products. Authorization to photocopy items for internal or personal use by Western Products outlets or sprayer owner is granted.

Western Products reserves the right under its product improvement policy to change construction or design details and furnish equipment when so altered without reference to illustrations or specifications used. Western Products may require or recommend optional equipment for sprayers. Western Products offers a limited warranty for all sprayers and accessories. See separately printed page for this important information. The following is a registered (®) trademark of Douglas Dynamics, LLC: WESTERN®.

Printed in U.S.A.