

UTV Electrical Installation Instructions

INSTALLING THE VEHICLE BATTERY CABLE AND CONTROL HARNESSSES

1. Before beginning this installation, remove the battery cables from the vehicle battery.
2. Route the vehicle battery cable from the front of the vehicle to the battery location. Make sure that the path avoids any hot, sharp, or moving parts of the vehicle.
5. Locate an accessory wire controlled by the ignition switch. Acceptable accessory wires show +12V when the ignition switch is ON, and 0V when the ignition is OFF.
6. Route the red wire from the vehicle control harness to this location and trim away any excess length.

NOTE: Do not connect the vehicle battery cable to the battery at this time.

3. Route the vehicle control harness into the UTV cab where the control will be installed.
4. Connect the vehicle control harness and vehicle battery cable at the six pin connectors as shown in the diagram below.

NOTE: If a longer control cable is required, an additional control cable (PN 80266) may be installed in series to extend the overall length. Only the fused accessory wire on the control cable closest to the control connector needs to be connected to ignition power. The unused fused tap end is to be covered with the supplied heatshrink tubing.

7. Follow the Recommended Splicing Procedure on the next page to splice the red wire into the switched accessory wire using the supplied parallel splices and heatshrink tubing.
8. Attach the red POSITIVE (+) vehicle battery cable to the in-line 200A fuse and the 8" red cable from the fuse to the existing UTV POSITIVE (+) battery post.
9. Attach the vehicle battery cable black wire and the UTV NEGATIVE (-) battery cable to the existing UTV NEGATIVE (-) battery post.
10. Secure the vehicle battery cable with the supplied zip ties.

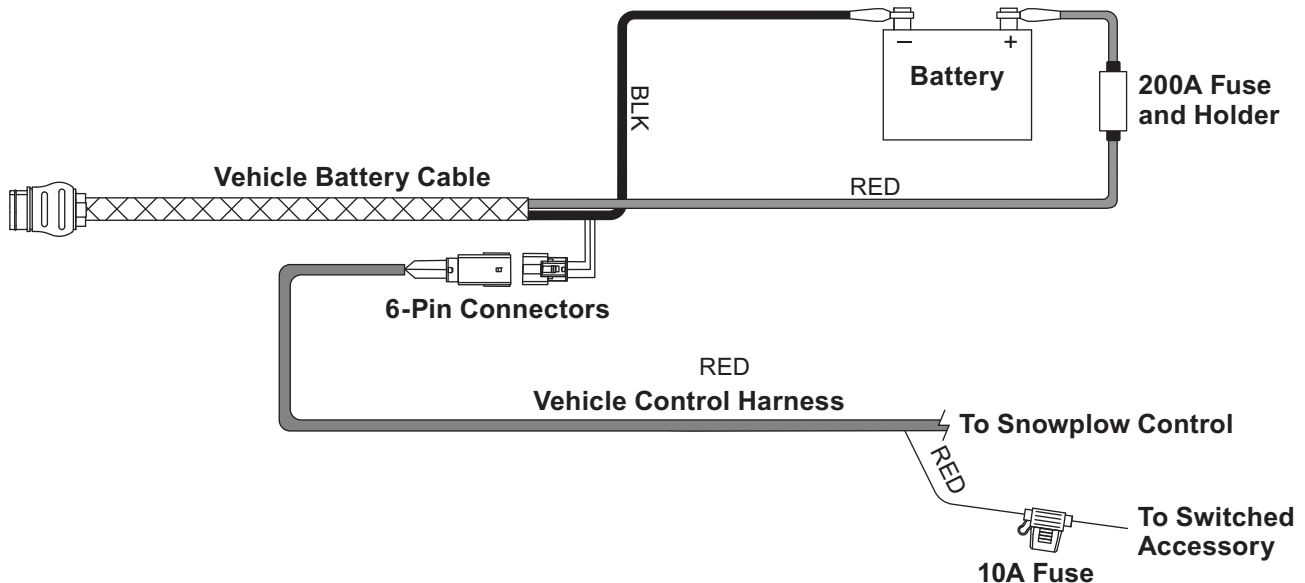

UTV ELECTRICAL INSTALLATION INSTRUCTIONS

RECOMMENDED SPLICING PROCEDURE

1. Locate the wire to be spliced into.
2. Cut the wire at least 1-1/2" from any other splice, connector, or terminal. If wires are covered by tubing or braid, remove enough of it to achieve the minimum clearance required.
3. Strip away 5/16" of the insulation from the ends of the wires to be spliced.
4. Slide two wires into one end of the supplied parallel splice.
5. Place a piece of heatshrink tubing (3/16" x 1-1/4") over the remaining wire to be spliced. Cut the tubing into 1-1/4" lengths if required.
6. Insert the wire into the open end of the splice and crimp using an appropriate crimp tool. One or two crimps may be necessary to ensure a good connection. No wire strands should be visible outside of the splice.
7. Preheat a soldering tool for at least one minute to help promote even solder flow.
8. Apply heat to the splice. Avoid heating too close to the insulation. Apply solder to the wires, using just enough solder to produce an even flow through the splice. **Use rosin core solder ONLY. Do not use acid core solder.**

NOTE: Avoid using an excessive amount of solder, as it can result in wicking. Wicking occurs when solder travels up the wire core. This may cause the wire to become stiff or brittle, which could lead to a broken or open circuit.

9. Check circuits for continuity.
10. Cover the splice with heatshrink tubing. The tubing should extend beyond the splice on both sides.
11. Using a hot air source, starting in the center and working to either side, apply heat until the tubing recovers and glue can be seen around the edges. Allow the tubing to cool before handling.

NOTE: The splices supplied will accommodate 18-gauge wires as shown. For larger-gauge wires, cut the wire, strip the ends 3/8" to 1/2" and twist together. Apply solder to the splice and cover with heatshrink tubing.

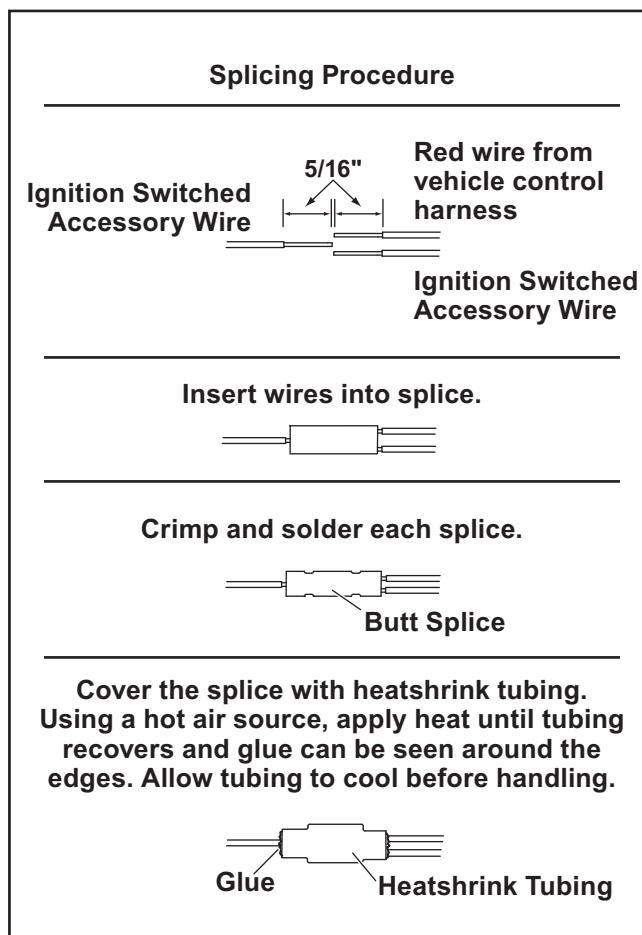

The company reserves the right under its product improvement policy to change construction or design details and furnish equipment when so altered without reference to illustrations or specifications used. This equipment manufacturer or the vehicle manufacturer may require or recommend optional equipment for snow removal. Do not exceed vehicle ratings with a snowplow. The company offers a limited warranty for all snowplows and accessories. See separately printed page for this important information.