

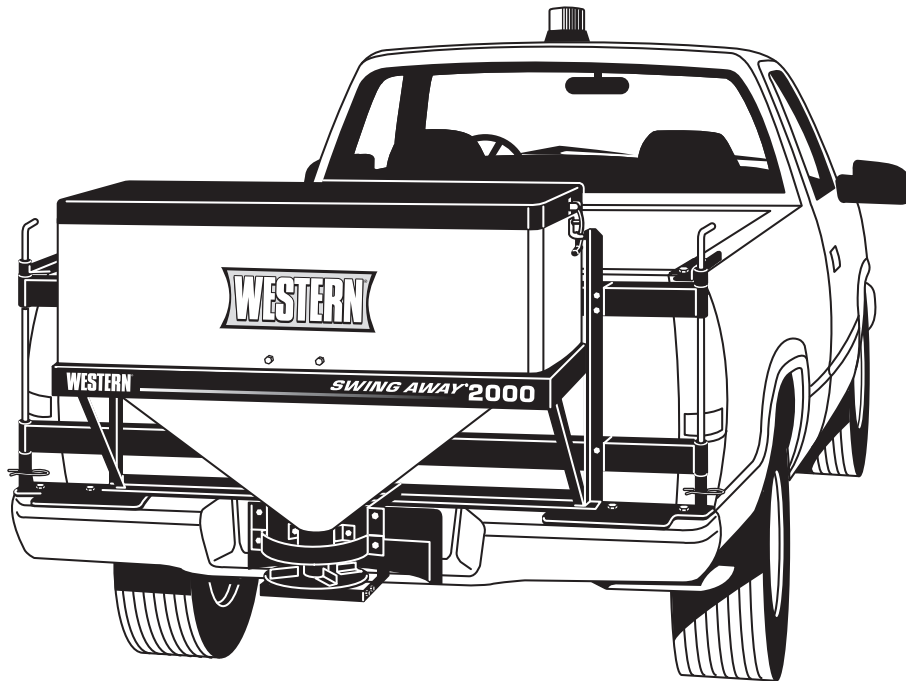

Low-Profile Tailgate Spreader

68800, 67440
Model 1000 & 2000

Owner's Manual
Original Instructions



⚠ CAUTION

**Read this manual before installing or
operating the spreader.**

This manual is for WESTERN® Model 1000 & 2000 Low-Profile Tailgate Spreaders with serial numbers 10003 and higher (Model 1000) and 20364 and higher (Model 2000).

This manual supersedes all editions with an earlier date.

TABLE OF CONTENTS

PREFACE	4	OPERATING THE SPREADER	13
Owner's Information Form	4	Driving and Spreading on Snow and Ice	13
SAFETY	5	Controls.....	14
Safety Definitions	5	Variable Speed (PWM) Control – New Style	14
Warning/Caution Labels	5	Variable Speed (PWM) Control – Old Style.....	16
Serial Number Label	6	ON/OFF Control.....	17
Safety Precautions.....	6	REMOVING THE SPREADER	18
Fuses	7	Receiver Mount.....	18
Personal Safety.....	7	Fixed Mount	18
Fire and Explosion	7	SWING AWAY Mount.....	19
Cell Phones.....	7	MAINTENANCE	20
Ventilation	8	Preseason Check.....	20
Battery Safety	8	After Each Use.....	20
Noise.....	8	Postseason Maintenance.....	21
Vibration.....	8	Drive Belt Replacement	21
Torque Chart.....	8	Bearing and Set Screw Maintenance	22
LOADING	9	Fuse Replacement.....	22
Certification.....	9	Recycle	22
Material Weights	9	4-PIN HARNESS WIRING DIAGRAM	23
MOUNTING THE SPREADER	10	2-PIN HARNESS WIRING DIAGRAM	24
Receiver Mount Spreader	10	TROUBLESHOOTING GUIDE	25
Fixed Mount Spreader	11		
SWING AWAY® Spreader	12		

PREFACE

This manual has been prepared to acquaint you with the safety information, operation, and maintenance of your new spreader. Please read this manual carefully and follow all recommendations. This will help ensure profitable and trouble-free operation of your spreader. Keep this manual accessible. It is a handy reference in case minor service is required.

When service is necessary, bring your spreader to your local dealer. They know your spreader best and are interested in your complete satisfaction.

NOTE: This spreader is designed to spread snow- and ice-control materials only. Do not use it for purposes other than those specified in this manual.

Register your spreader online at www.westernplows.com

Owner Name: _____

Date Purchased: _____

Dealer Name: _____ Phone: _____

Dealer Address: _____

Vehicle Model/Year: _____

Spreader Type/Size (Model): _____ Weight: _____ lb/kg

Spreader Serial Number: _____

SAFETY

SAFETY DEFINITIONS

⚠ WARNING

Indicates a potentially hazardous situation that, if not avoided, could result in death or serious personal injury.

⚠ CAUTION

Indicates a potentially hazardous situation that, if not avoided, may result in minor to moderate injury. It may also be used to alert against unsafe practices.

NOTE: Indicates a situation or action that can lead to damage to your spreader and vehicle or other property. Other useful information can also be described.

Caution Label (both sides, SWING AWAY® mount only)



WARNING/CAUTION LABELS

Please become familiar with and inform users about the warning and caution labels on the spreader.

NOTE: If labels are missing or cannot be read, see your sales outlet.

Warning Label (receiver mount only)

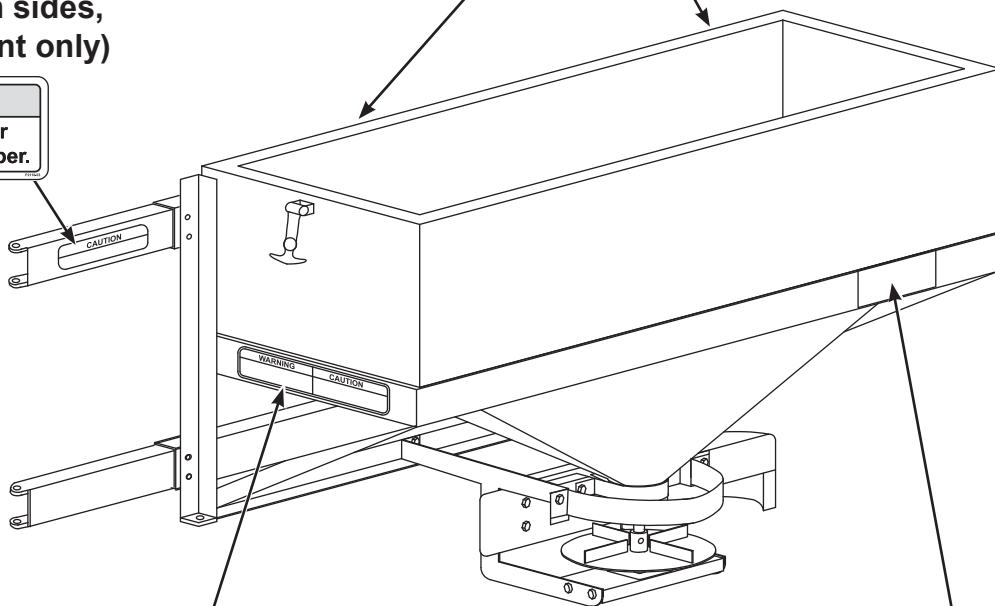
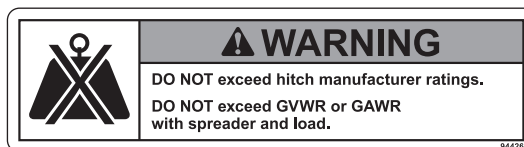

Warning Label

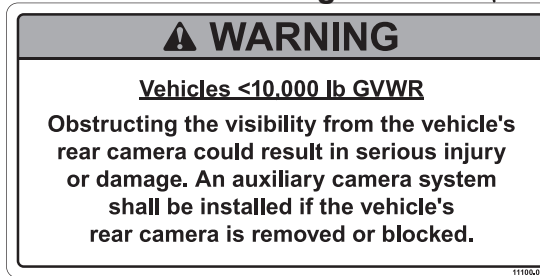

Warning/Caution Label (both sides)

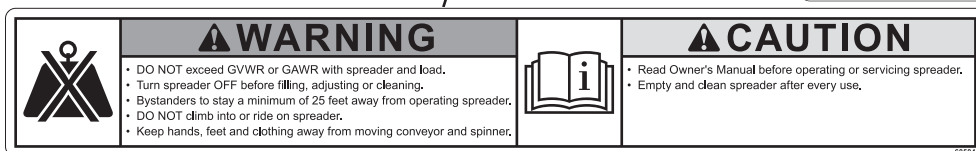

SAFETY

SERIAL NUMBER LABEL

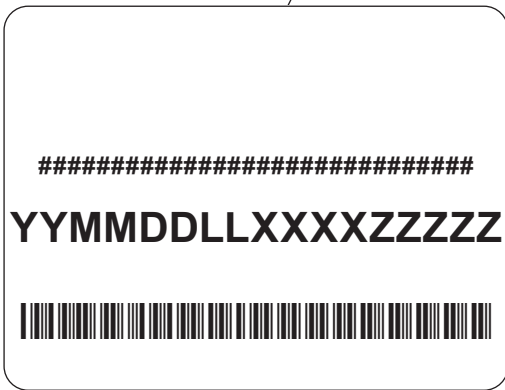
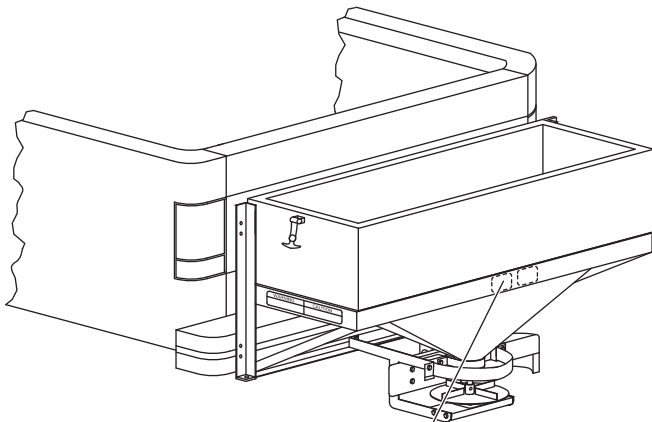

Code	Definition
YY	2-Digit Year
MM	2-Digit Month
DD	2-Digit Day
LL	2-Digit Location Code
XXXX	4-Digit Sequential Number
ZZZZZ	5-7-Digit Assembly PN

SAFETY PRECAUTIONS

Improper installation and operation could cause personal injury and/or equipment and property damage. Read and understand labels and this Owner's Manual before installing, operating, or making adjustments.

⚠ WARNING

- Driver to keep bystanders minimum of 25 feet away from operating spreader.
- Before working with the spreader, secure all loose-fitting clothing and unrestrained hair.
- Before operating the spreader, verify that all safety guards are in place.
- Before servicing the spreader, wait for conveyor, auger, and spinner to stop.
- Do not climb into or ride on spreader.

⚠ WARNING



Overloading could result in an accident or damage. Do not exceed GVWR or GAWR ratings as found on the driver-side vehicle door cornerpost. See Loading section to determine maximum volumes of spreading material.

⚠ WARNING

Do not install the control for this product in the deployment path of an air bag. Refer to vehicle manufacturer's manual for air bag deployment area(s).

⚠ WARNING

Vehicles <10,000 lb GVWR: Obstructing the visibility from the vehicle's rear camera could result in serious injury or damage. An auxiliary camera system shall be installed if the vehicle's rear camera is removed or blocked.

⚠ CAUTION

If rear directional, CHMSL light, or brake stoplights are obstructed by the spreader, the lights shall be relocated, or auxiliary directional or brake stoplights shall be installed.

SAFETY

CAUTION

During the hopper installation we recommend the addition of an OSHA compliant Backup Alarm. This alarm is required for OSHA governed employers.

CAUTION

- Do not operate a spreader in need of maintenance.
- Before operating the spreader, reassemble any parts or hardware removed for cleaning or adjusting.
- Before operating the spreader, remove materials such as cleaning rags, brushes, and hand tools from the spreader.
- Before operating the spreader, read the engine owner's manual, if so equipped.
- While operating the spreader, use auxiliary warning lights, except when prohibited by law.
- Tighten all fasteners according to the Torque Chart. Refer to Torque Chart for the recommended torque values.

CAUTION

Disconnect electric and/or hydraulic power and tag out if required before servicing or performing maintenance.

CAUTION



DO NOT leave unused material in hopper. Material can freeze or solidify, causing unit to not work properly. Empty and clean after each use.

NOTE: Lubricate grease fittings after each use. Use a good quality multipurpose grease.

FUSES

The electrical system contains several automotive-style fuses. If a problem should occur and fuse replacement is necessary, the replacement fuse must be of the same type and amperage rating as the original. Installing a fuse with a higher rating can damage the system and could start a fire. Fuse Replacement, including fuse ratings and locations, is located in the Maintenance section of this Owner's Manual.

PERSONAL SAFETY

- Remove ignition key and put the vehicle in PARK or in gear to prevent others from starting the vehicle during installation or service.
- Wear only snug-fitting clothing while working on your vehicle or spreader.
- Do not wear jewelry or a necktie, and secure long hair.
- Wear safety goggles to protect your eyes from battery acid, gasoline, dirt, and dust.
- Avoid touching hot surfaces such as the engine, radiator, hoses, and exhaust pipes.
- Always have a fire extinguisher rated BC handy, for flammable liquids and electrical fires.

FIRE AND EXPLOSION

WARNING

Gasoline is highly flammable and gasoline vapor is explosive. Never smoke while working on vehicle. Keep all open flames away from gasoline tank and lines. Wipe up any spilled gasoline immediately.

Be careful when using gasoline. Do not use gasoline to clean parts. Store only in approved containers away from sources of heat or flame.

CELL PHONES

A driver's first responsibility is the safe operation of the vehicle. The most important thing you can do to prevent a crash is to avoid distractions and pay attention to the road. Wait until it is safe to operate Mobile Communication Equipment such as cell phones, text messaging devices, pagers, or two-way radios.

SAFETY

VENTILATION

⚠ WARNING

Vehicle exhaust contains lethal fumes. Breathing these fumes, even in low concentrations, can cause death. Never operate a vehicle in an enclosed area without venting exhaust to the outside.

BATTERY SAFETY

⚠ CAUTION

Batteries normally produce explosive gases, which can cause personal injury. Therefore, do not allow flames, sparks, or lit tobacco to come near the battery. When charging or working near a battery, always cover your face and protect your eyes, and also provide ventilation.

- Batteries contain sulfuric acid, which burns skin, eyes, and clothing.
- Disconnect the battery before removing or replacing any electrical components.

NOISE

Airborne noise emission during use is below 70 dB(A) for the spreader operator.









VIBRATION

Operating spreader vibration does not exceed 2.5 m/s² to the hand-arm or 0.5 m/s² to the whole body.

TORQUE CHART

⚠ CAUTION

Read instructions before assembling. Fasteners should be finger tight until instructed to tighten according to torque chart. Use standard methods and practices when attaching spreader including proper personal protective safety equipment.

Recommended Fastener Torque Chart					
Inch Fasteners Grade 5 and Grade 8					
Size	Torque (ft-lb)		Size	Torque (ft-lb)	
	 Grade 5	 Grade 8		 Grade 5	 Grade 8
1/4-20	8.4	11.9	9/16-12	109	154
1/4-28	9.7	13.7	9/16-18	121	171
5/16-18	17.4	24.6	5/8-11	150	212
5/16-24	19.2	27.3	5/8-18	170	240
3/8-16	30.8	43.6	3/4-10	269	376
3/8-24	35.0	49.4	3/4-16	297	420
7/16-14	49.4	69.8	7/8-9	429	606
7/16-20	55.2	77.9	7/8-14	474	669
1/2-13	75.3	106.4	1-8	644	909
1/2-20	85.0	120.0	1-12	704	995
Metric Fasteners Class 8.8 and 10.9					
Size	Torque (ft-lb)		Size	Torque (ft-lb)	
	 Class 8.8	 Class 10.9		 Class 8.8	 Class 10.9
M6 x 1.00	7.7	11.1	M20 x 2.50	325	450
M8 x 1.25	19.5	26.9	M22 x 2.50	428	613
M10 x 1.50	38.5	53.3	M24 x 3.00	562	778
M12 x 1.75	67	93	M27 x 3.00	796	1139
M14 x 2.00	107	148	M30 x 3.50	1117	1545
M16 x 2.00	167	231	M33 x 3.50	1468	2101
M18 x 2.50	222	318	M36 x 4.00	1952	2701
These torque values apply to fasteners except those noted in the instructions.					

LOADING

This Owner's Manual covers vehicles that have been recommended for carrying the tailgate spreader. Please see your local dealer for proper vehicle applications.

CERTIFICATION

⚠ WARNING

New untitled vehicle installation of a spreader requires National Highway Traffic Safety Administration altered vehicle certification labeling. Installer to verify that struck load of snow or ice control material does not exceed GVWR or GAWR rating label and complies with FMVSS.

⚠ WARNING

Overloading could result in an accident or damage. Do not exceed GVWR or GAWR ratings as found on the driver-side vehicle door cornerpost.

⚠ CAUTION



Read and adhere to manufacturer's ice-control material package labeling, including Material Safety Data Sheet requirements.

MATERIAL WEIGHTS

Material	Density		
	(lb/ft ³)	(lb/yd ³)	(kg/m ³)
Salt	80	2160	1282
Sand	100	2700	1602

Material densities are approximate and are based on dry, loose material. It is the responsibility of the operator to know the weight of the material to be spread and the vehicle carrying capacity.

NOTE: If spreader and ice control material loading is in doubt, weigh vehicle for compliance with vehicle ratings.

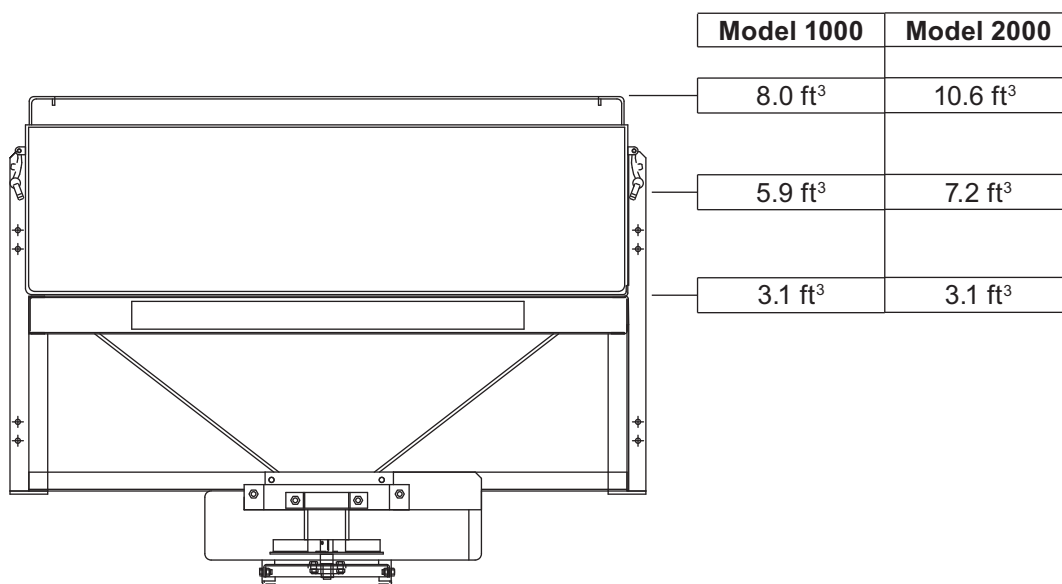

RECEIVER MOUNT SPREADER

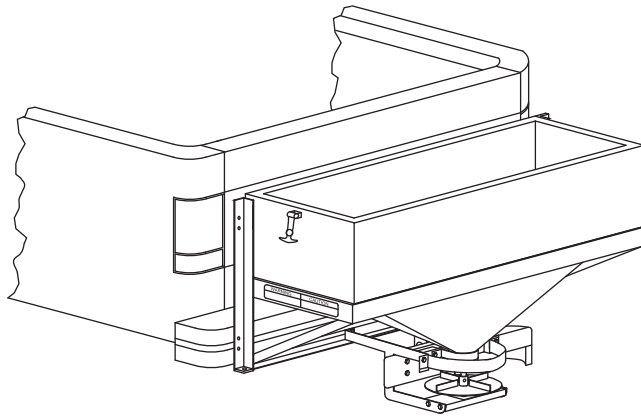

1. Attach the spreader to the receiver mount with six 3/8" x 1" cap screws.
2. Insert the assembled unit into the receiver hitch and secure with pin (not included).
3. Plug the spreader harness into the vehicle harness.
4. Use the supplied ratchet straps to secure the assembly to the vehicle frame.

Attaching the straps to the vehicle bumper or tailgate may result in vehicle or spreader damage.

⚠ CAUTION

During removal or mounting, securely grip spreader to avoid dropping.

NOTE: The spreader shall be installed according to instructions supplied. Your local outlet is trained to provide this service and service your spreader with factory original parts.

FIXED MOUNT SPREADER

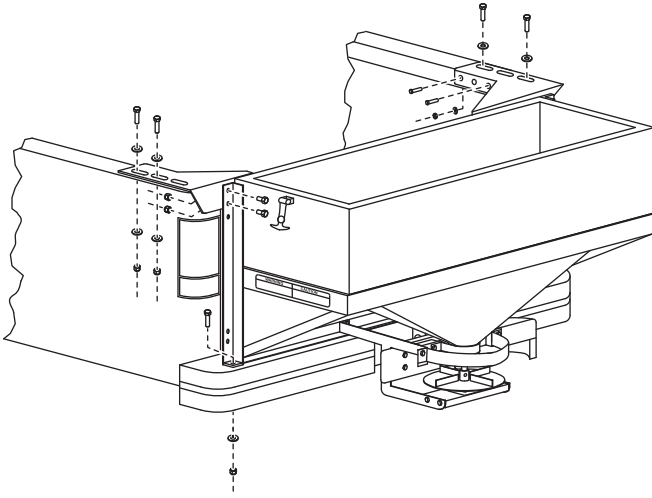

⚠ CAUTION

During removal or mounting, securely grip spreader to avoid dropping.

NOTE: The spreader shall be installed according to instructions supplied. Your local outlet is trained to provide this service and service your spreader with factory original parts.

1. Install the left and right top brackets to the truck bed rail with two 1/2" cap screws, four 1/2" flat washers, and two 1/2" locknuts per side. Secure the small mounting flange of each top bracket to the bed rail using two 5/16" cap screws, two 5/16" flat washers, and two 5/16" locknuts per side.

NOTE: Pay special attention when drilling or clamping dissimilar metals to aluminum bodies. Galvanic corrosion can occur if not handled properly. Contact vehicle manufacturer for recommended attachment practices.

2. Place the spreader on the bumper and line up the holes in the bottom feet with the holes in the bumper.
3. Attach the spreader to the top brackets using two 3/8" cap screws and two 3/8" locknuts per side.
4. Attach the spreader to the bumper of the truck using one 3/8" cap screw, one 3/8" flat washer, and one 3/8" locknut per side.
5. Plug the spreader harness into the vehicle harness.

SWING AWAY® SPREADER

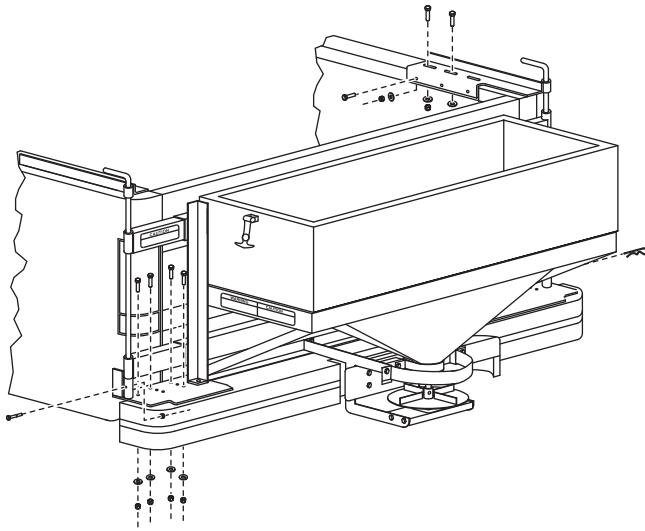

⚠ CAUTION

During removal or mounting, securely grip spreader to avoid dropping.

NOTE: The spreader shall be installed according to instructions supplied. Your local outlet is trained to provide this service and service your spreader with factory original parts.

1. Fasten the left and right top brackets along with any shims to the truck bed rail with two 1/2" cap screws, two 1/2" flat washers, and two 1/2" locknuts per bracket. Install the two 5/16" cap screws and 5/16" locknuts to the side of the top brackets.

NOTE: Pay special attention when drilling or clamping dissimilar metals to aluminum bodies. Galvanic corrosion can occur if not handled properly. Contact vehicle manufacturer for recommended attachment practices.

2. Place the left and right base plates on the bumper of the truck and line up with the holes in the bumper.
3. Attach the base plates to the bumper using three 3/8" cap screws, three 3/8" plain washers, any shims, and three 3/8" locknuts per side.
4. Place the spreader on the base plates and insert the hinge pins. Secure the hinge side by installing one 1/4" cap screw and 1/4" locknut through the hole in the base plate boss and hinge pin.
5. Install hitch pin clip through the base plate boss and the removable hinge pin.
6. Plug the spreader harness into the vehicle harness.
7. Plug the center high mounted stoplight (CHMSL) cord into the vehicle stoplight harness.

DRIVING AND SPREADING ON SNOW AND ICE

CAUTION

Drinking and then driving or spreading is very dangerous. Your reflexes, perceptions, attentiveness, and judgment can be affected by even a small amount of alcohol. You can have a serious or even fatal collision if you drive after drinking. Please do not drink then drive or spread ice-control materials.

Follow your vehicle owner's manual instructions for driving in snow and ice conditions. Remember, when you drive on snow or ice, your wheels will not get good traction. You cannot accelerate as quickly, turning is more difficult, and you will need longer braking distance. Wet and hard packed snow or ice offer the worst tire traction. It is very easy to lose control. You will have difficulty accelerating. If you do get moving, you may have poor steering and difficult braking, which can cause you to slide out of control.

Here are some tips for driving in these conditions:

- Drive defensively.
- Do not drink, then drive or spread ice-control materials.
- Spread or drive only when you have good visibility for operating a vehicle.
- If you cannot see well due to snow or icy conditions, you will need to slow down and keep more space between you and other vehicles.
- Slow down, especially on higher-speed roads. Your headlamps can light up only so much road ahead.
- If you are tired, pull off in a safe place and rest.
- The spreader's size and location reduce driver visibility to the rear of the vehicle. We recommend an OSHA-compliant backup alarm for all governed employers.
- Keep your windshield and all glass on your vehicle clean to see around you.
- Dress properly for the weather. Wear layers of clothing; as you get warm, you can take off layers.

CONTROLS

There are two control options. They include the Variable Speed (PWM) Control and the ON/OFF Control. Both have had design changes. Identify older and newer styles by the face plate diagrams below to find the appropriate operating instructions.

⚠ CAUTION

If the unit is equipped with a SWING AWAY® mount, both hinge pins must be secured in the base plates before operating the spreader or the vehicle.

Variable Speed (PWM) Control – New Style

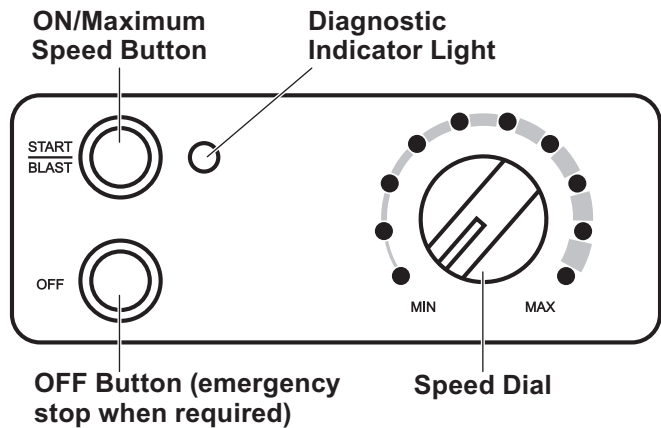

⚠ WARNING

Before starting the spreader, the driver shall verify all bystanders are a minimum of 25 feet away from operating spreader.

Starting and Stopping the Motor

1. To start the spreader motor, press the START/BLAST button and release. Both the START/BLAST and OFF buttons will be backlit when the motor is running. The spreader will operate at the speed selected on the speed dial.
2. Press the OFF button to stop the motor.

The OFF button operates as an emergency stop when required.

NOTE: The truck ignition must be ON to start the spreader.

NOTE: If the truck ignition is turned OFF while the spreader is running, the motor will stop.

Adjusting the Spinner Speed

The speed setting can be adjusted when the spreader is either ON or OFF.

1. Turn the speed dial clockwise. The speed will increase as the number of green LEDs illuminated on the speed dial increases.
2. Turning the speed dial counterclockwise will decrease the speed.

BLAST/Maximum Speed

1. Press and hold the START/BLAST button as long as maximum speed is needed.
2. Release the button when maximum speed is no longer needed. The control automatically returns to the "ON" position and the speed shown on the speed dial.

NOTE: When BLAST is used, the speed dial does not move to the maximum speed setting, but remains at the preset speed.

Diagnostic Indicator Light

The diagnostic indicator light located to the right of the START/BLAST button remains dark unless a problem with the motor or wiring is detected. The light will flash a number of flashes in a row, pause, then repeat. Count the flashes to determine the nature of the malfunction and refer to the diagnostic chart below.

# of Flashes	Problem	Possible Causes
0	No fault	—
2	No power	Battery fuse is blown, or battery cable is disconnected or faulty.
3	No motor	Motor is disconnected.
4	No ground	Spreader harness ground is disconnected or faulty.
5	Overheated	Motor OFF due to controller overheat, possibly caused by frozen or jammed spreader.
6	Excess current	Over 35A for more than 1–2 seconds. (Higher overloads are allowed for shorter periods.)

If additional information is needed, refer to the Troubleshooting section of this manual.

NOTE: Always place the cover on the hopper to prevent moisture buildup. Do not let the spreader sit idle with material in the hopper for an extended period of time. This can cause the material to compact and reduce or stop the flow of material.

CAUTION

Do not swing spreader with material in the hopper.

Variable Speed (PWM) Control – Old Style

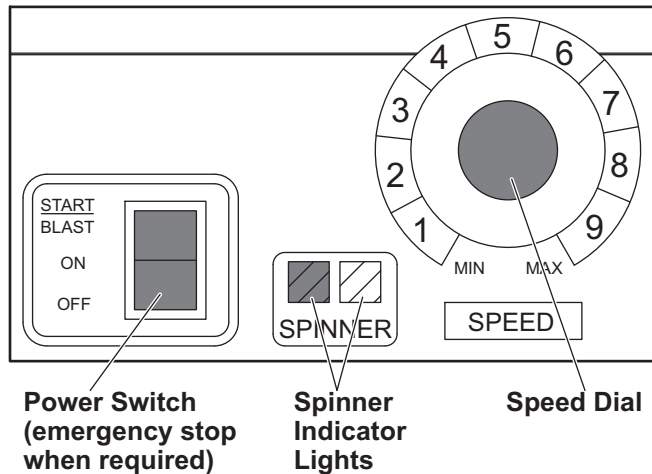

Starting and Stopping the Motor

⚠ WARNING

Before starting the spreader, the driver shall verify that all bystanders are a minimum of 25 feet away from operating spreader.

1. To start the spreader motor, press the power switch to the "START/BLAST" position and release. This is a momentary position and the power switch will automatically return to the "ON" position when released. The spreader will operate at the speed selected on the speed dial.
2. Press the power switch to the "OFF" position to stop the motor. The power switch will remain in this position.

The power switch "OFF" position operates as an emergency stop when required.

NOTE: The truck ignition must be ON to start the spreader.

NOTE: If the truck ignition is turned OFF while the spreader is running, the motor will stop.

Adjusting the Spinner Speed

The speed setting can be adjusted when the spreader is either ON or OFF.

1. Turn the speed dial clockwise. Speed will increase as the numbers on the speed dial increase.
2. Turning the speed dial counterclockwise will decrease the speed.

BLAST/Maximum Speed

3. Press and hold the power switch in the "START/BLAST" position as long as maximum speed is needed.
4. Release the power switch when maximum speed is no longer needed. The switch automatically returns to the "ON" position and the speed shown on the speed dial.

NOTE: When BLAST is used, the speed dial does not move to the maximum speed setting, but remains at the preset speed.

Spinner Indicator Lights

Two lights on the cab control indicate the status of the motor:

- Left light is red and indicates a fault. When the red (left) light is ON, the power is ON and the motor is not running.
- Right light is green and indicates power is ON. When the green (right) light is ON, there is power to the control and the motor is running.

If there are problems while operating the spreader, refer to the Troubleshooting section of this manual.

NOTE: Always place the cover on the hopper to prevent moisture buildup. Do not let the spreader sit idle with material in the hopper for an extended period of time. This can cause the material to compact and reduce or stop the flow of material.

⚠ CAUTION

Do not swing spreader with material in the hopper.

ON/OFF Control

New Style

Spinner Indicator Light
(when lit, indicates
power to the motor)

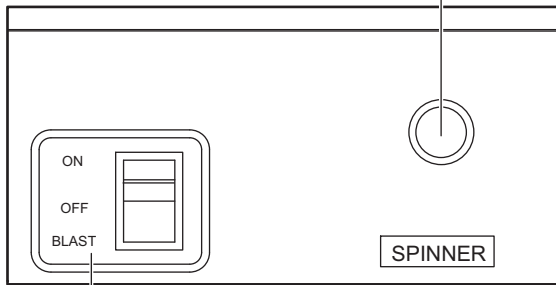

ON/OFF Control Switch
(emergency stop
when required)

Old Style

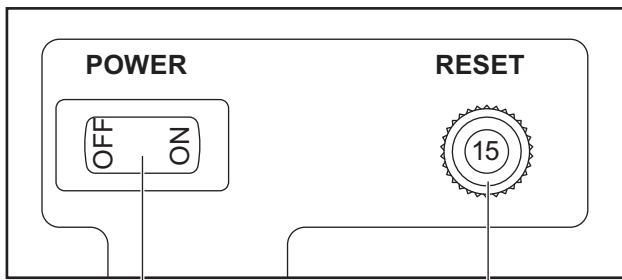

ON/OFF Control Switch
(emergency stop
when required)

Circuit Breaker
(resets control)

Starting and Stopping the Motor

⚠ WARNING

Before starting the spreader, the driver shall verify that all bystanders are a minimum of 25 feet away from operating spreader.

1. Move the power switch to the "ON" position to start the motor. The motor will start immediately. The power switch will remain in this position.
2. Move the power switch to the "OFF" position to stop the motor. The power switch will remain in this position.

The power switch "OFF" position operates as an emergency stop when required.

NOTE: The truck ignition must be ON to start the spreader.

NOTE: If the truck ignition is turned OFF while the spreader is running, the motor will stop.

BLAST/Maximum Speed (New Style Only)

Move and hold the power switch to the "BLAST" position for as long as maximum speed is needed. When released, the switch will automatically return to the "OFF" position and stop the motor.

If there are problems while operating the spreader, refer to the Troubleshooting section in this manual.

NOTE: Always place the cover on the hopper to prevent moisture buildup. Do not let the spreader sit idle with material in the hopper for an extended period of time. This can cause the material to compact and reduce or stop the flow of material.

⚠ CAUTION

Do not swing spreader with material in the hopper.

⚠ CAUTION

Empty the hopper before removing the spreader.

⚠ CAUTION

During removal or mounting, securely grip spreader to avoid dropping.

RECEIVER MOUNT

Removing the Spreader

1. Unplug the spreader.
2. Remove the pin from the receiver hitch.
3. Remove the spreader from the vehicle and stand it in an upright position. This may require additional support.

FIXED MOUNT

Removing the Spreader

1. Unplug the spreader and CHMSL (if equipped).
2. Remove the two 3/8" cap screws, washers, and locknuts that fasten the spreader to the bumper of the vehicle.
3. Use an additional person or clamps to support the unit and then remove the four 3/8" cap screws and locknuts that fasten the spreader to the top brackets.
4. Remove the spreader from the vehicle and stand in an upright position. This may require additional support.

Removing the Brackets

1. Remove the two 1/2" cap screws, washers, and locknuts that fasten each top bracket to the bed rail.
2. Remove the two 5/16" cap screws, washers, and locknuts that fasten each top bracket to the side of the bed rail.
3. Package the brackets with all hardware and store them with the unit.

SWING AWAY® MOUNT

Removing the Spreader

1. Unplug the spreader and CHMSL (if equipped).
2. Remove the hitch pin from the latch-side hinge pin.
3. Remove the 1/4" cap screw and locknut from the hinged-side hinge pin.
4. Use an additional person to support the unit and remove both hinge pins.
5. Remove the spreader from the vehicle and stand it in an upright position. This may require additional support.

Removing the Top Brackets

1. Remove the two 1/2" cap screws, washers, and locknuts that fasten each top bracket to the bed rail.
2. Remove the two 5/16" cap screws and locknuts that fasten each top bracket to the side of the bed rail.
3. Mark the location of any shims to aid in reinstallation.
4. Package the brackets with all hardware and store with the unit.

Removing the Base Plates

1. Remove the four 3/8" cap screws, washers, locknuts, and any shims that fasten the base plate to the bumper.
2. Mark the location of the shims to aid in reinstallation.
3. Package the base plates with all hardware and store with the unit.

MAINTENANCE

CAUTION

Disconnect electric power at spreader electrical wiring harness connection and tag out if required before servicing or performing maintenance.

CAUTION

- Do not operate a spreader in need of maintenance.
- Before operating the spreader, reassemble any parts or hardware removed for cleaning or adjusting.
- Before operating the spreader, remove materials such as cleaning rags, brushes, and hand tools from the spreader.
- Empty and clean spreader after every use. Material can freeze or solidify, causing unit to not work properly.

PRESEASON CHECK

Before the unit is placed in service for the ice control season, make sure that it is in top working condition. Here are some tips for getting your spreader ready.

Remove the motor cap assembly and inspect the following:

1. Check the condition of the drive belt. Any cracks or damaged teeth indicate the need for a new belt. See "Drive Belt Replacement" in this section.
2. Check the motor connection terminals for damage or corrosion. Clean or replace as necessary and coat with dielectric grease.
3. Check the condition of the drive shaft bearings by first removing the drive belt. To remove the drive belt see "Drive Belt Replacement" in this section. With the drive belt removed, spin the drive shaft by hand. Any excess noise or roughness in either bearing may indicate bearing failure.

4. If bearings pass inspection, be sure to thoroughly grease them with a good quality multipurpose grease. See "Bearing and Set Screw Maintenance" in this section.
5. Verify that all drive sprocket set screws are tight. Verify that all other fasteners are tight. Refer to the torque chart in the Safety section of this manual.
6. Check the condition of the motor cap assembly seal. This seal is very important to the reliability of the unit. Replace the seal if needed.
7. Check the condition of the spinner disk. If the vanes are excessively worn, the unit may not spread as intended. Replace the spinner if necessary.
8. Replace the motor cap assembly and locknuts.
9. Verify that vehicle stoplights and spreader CHMSL are visible and working properly.

AFTER EACH USE

Disconnect the electrical plug located between the spreader and the truck before cleaning.

1. Thoroughly clean the unit inside and out using tap water or a high-pressure washer. Avoid spraying water into bearings, motor, and electrical connections. A long-handled brush can be used to aid cleaning.
2. Apply dielectric grease to all electrical connections to prevent corrosion.
3. Lubricate the drive shaft bearings with a good quality multipurpose grease.

MAINTENANCE

POSTSEASON MAINTENANCE

⚠ CAUTION

Disconnect electric power at spreader electrical wiring harness connection and tag out if required before servicing or performing maintenance.

Before storing the unit for the off-season, taking a few minutes to do the following will extend the service life of your spreader:

1. Thoroughly clean the unit inside and out.
2. Apply dielectric grease to all electrical connections to prevent corrosion.
3. Grease the drive shaft bearings.
4. Oil or paint all bare metal surfaces.
5. Place the lid on the hopper body of the unit and secure the latch.
6. Store the unit in an upright position; stabilize it with supports if necessary. If the unit is stored outdoors, cover the unit and place it on blocks to avoid ground moisture.

DRIVE BELT REPLACEMENT

⚠ CAUTION

Disconnect electric power at spreader electrical wiring harness connection and tag out if required before servicing or performing maintenance.

⚠ CAUTION

Overtightening the belt may result in damage to the motor or bearings.

1. Disconnect the electrical plug between the spreader and truck. Remove the motor cap assembly.
2. Loosen the four Phillips head screws that fasten the motor mount to the drive support.
3. Slide the motor toward the drive shaft.
4. Remove the belt and replace with a new one.
5. Slide the motor mount away from the drive shaft until the proper tension of the drive belt is achieved. After tightening the belt should easily deflect 3/8".

Phillips Head Screws

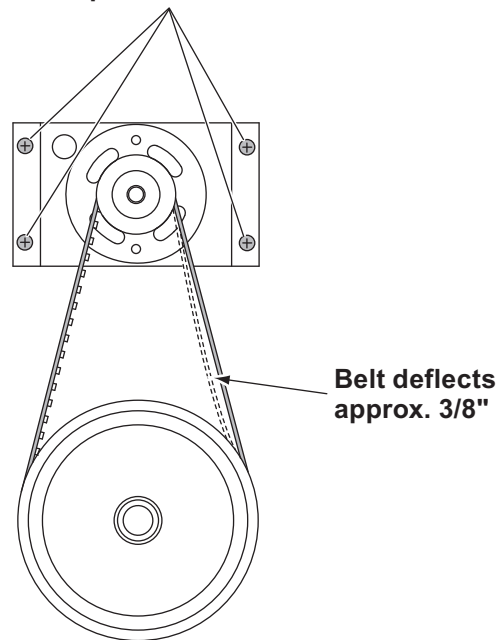

6. Tighten the four Phillips head screws and replace the motor cap.

BEARING AND SET SCREW MAINTENANCE

Disconnect the electrical plug between the spreader and the truck before performing any maintenance.

1. Tighten all set screws shown after every 60 hours of use.
2. Grease the top and bottom drive shaft bearings as shown below, using a good quality multipurpose grease. Due to the harsh environment of the bottom bearing, it will require more maintenance than the top bearing.

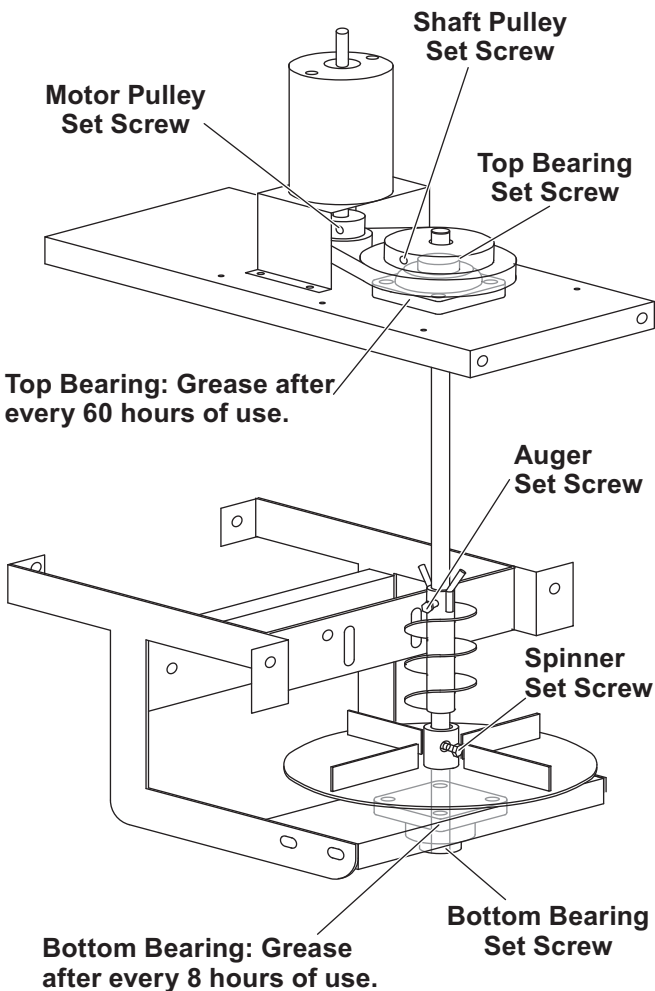

Lubricate drive shaft bearings with a good quality multipurpose grease.

FUSE REPLACEMENT

See the harness wiring diagrams on the following pages for fuse ratings and locations.

If a problem should occur and fuse replacement is necessary, the replacement fuse must be of the same type and amperage rating as the original. Installing a fuse with a higher rating can damage the system and could start a fire.

RECYCLE

When your spreader has performed its useful life, the majority of its components can be recycled as steel. Gear oil shall be disposed of according to local regulations. Balance of parts made of plastic shall be disposed of in customary manner.

4-PIN HARNESS WIRING DIAGRAM – LOW-PROFILE SPREADERS

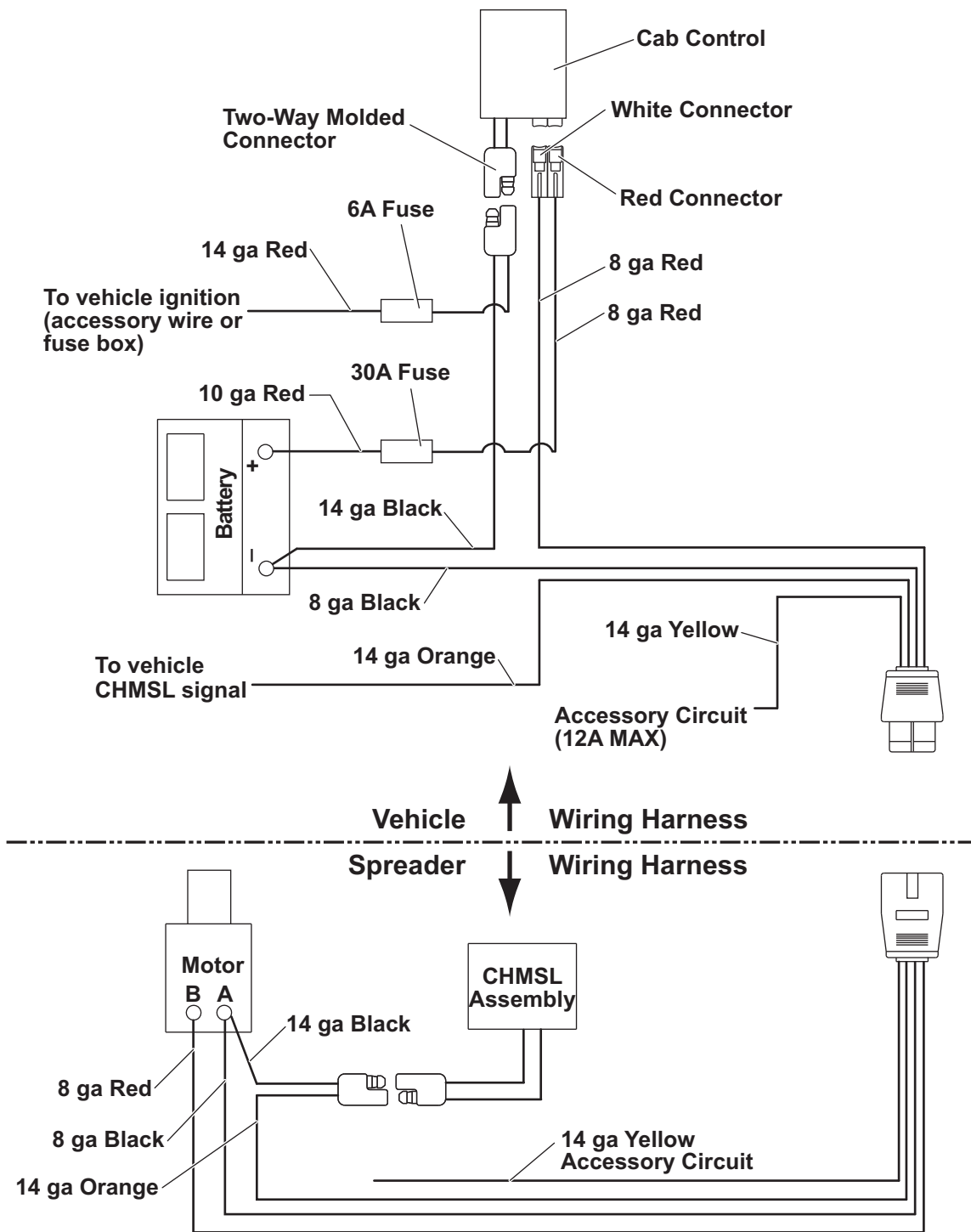

Motor Specification: 12V DC, .56 kW

2-PIN HARNESS WIRING DIAGRAM – LOW-PROFILE SPREADERS

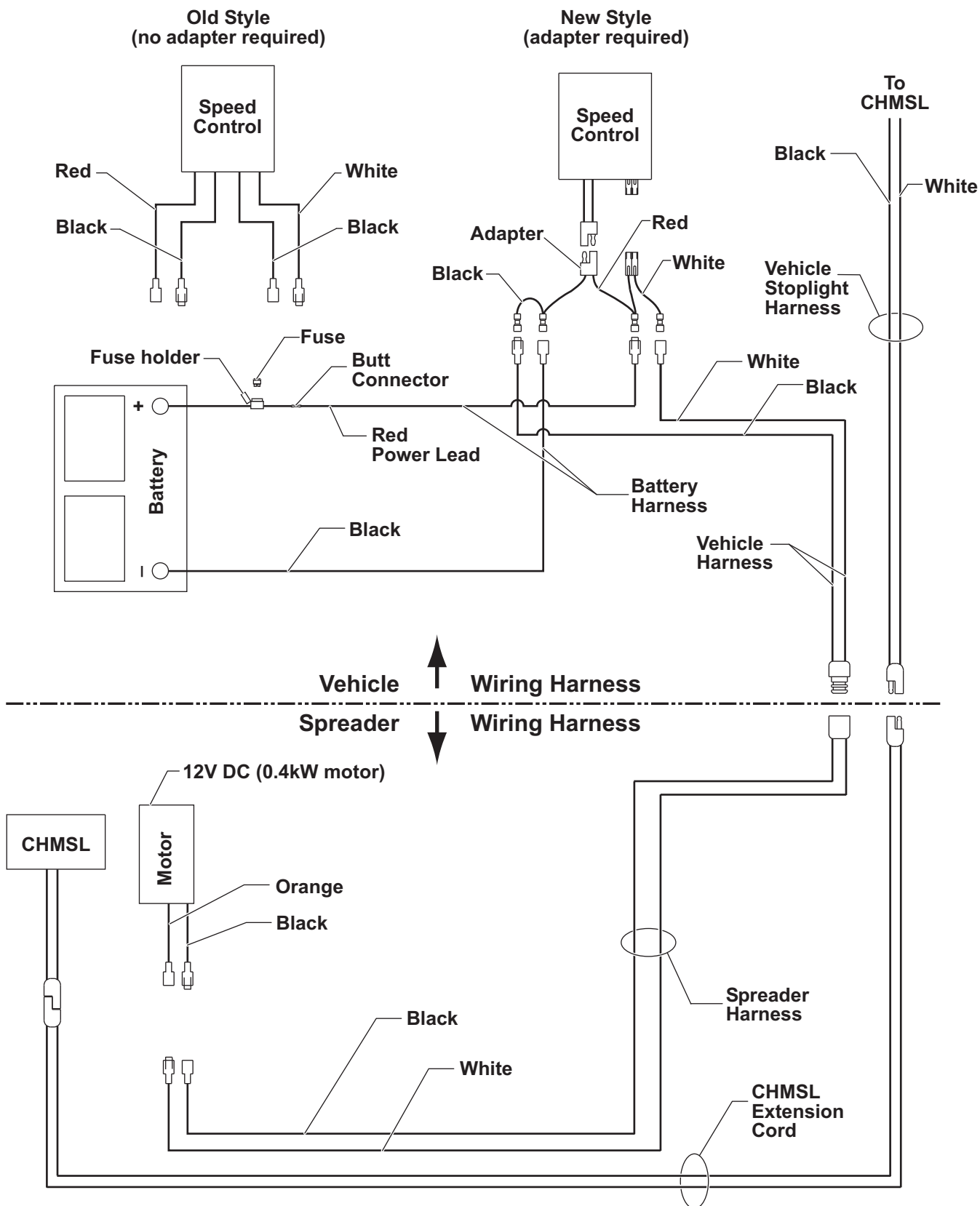

www.storksplows.com
TROUBLESHOOTING GUIDE

For control operation and use of diagnostic indicator lights, locate the section for your control style in the Operating the Spreader section of this manual.

Problem	Possible Cause	Suggested Solution
No power to cab control. Ignition and control switches ON; no illumination of indicator light(s).	1. Control connector plug is loose.	1. Check plug connection at cab control.
	2. Battery lead in-line fuse is blown.	2. Change the fuse (30A) and inspect for short circuits. Check power supply for 12V DC.
	3. Battery connection is poor.	3a. Check for low battery. 3b. Clean or replace ring terminal. Coat with dielectric grease.
	4. Battery wiring harness is damaged.	4. Repair or replace damaged wires or harness as required.
	5. Control circuit breaker is tripped (old style ON/OFF control only).	5. Turn the control OFF. Reset the circuit breaker and turn the control ON.
Speed control dial on the Variable Speed (PWM) cab control does not change motor speed.	1. Malfunctioning cab control.	1. Replace cab control.
	2. Red and white connectors are incorrectly hooked up.	2. Reconnect so that red matches red and white matches white.
Spreader does not operate. Indicator light(s) illuminated.	1. Overloaded condition is causing over-current protection to activate (variable speed control only).	1. Reset cab control by turning the power OFF. Depress the START/BLAST switch to resume operation.
	2. Wire harness is damaged or has an open circuit between cab control and spreader.	2a. Check plug connections at cab control and spreader. 2b. Check wire connections at spreader motor and at vehicle battery, disconnect motor leads, turn control ON, set cab control to MAXIMUM on variable speed controls and check for voltage at motor leads. 2c. Repair or replace damaged wires and connectors. 2d. Check the 30A in-line fuse. Replace if necessary.
	3. Spreader motor is not running.	3. Replace motor if shaft will not turn.

www.storksplows.com
TROUBLESHOOTING GUIDE

Problem	Possible Cause	Suggested Solution
Spinner does not turn. Motor is running.	Unplug the spreader harness and tag out, if required, before performing any of the following repairs.	
	1. Obstruction is preventing rotation.	1. Clear obstruction.
	2. Drive belt is loose or damaged.	2. Adjust tension or replace belt if worn or damaged.
	3. Motor pulley not secured to motor shaft.	3. Tighten pulley set screw or replace pulley if damaged.
	4. Spinner pulley is not secured to spinner shaft.	4. Replace cap screw and nut if missing or damaged. Replace pulley if damaged.
	5. Spinner shaft bearings are dry or seized.	5. Grease or replace bearings.
Ice control material not flowing. Spinner is turning.	1. Bridging of material or obstruction in hopper.	1. Unplug the spreader harness and tag out if required. Check hopper for material and free any bridged material or obstruction.
Spread pattern not optimum.	1. Deflector out of adjustment. (optional equipment).	1. Unplug the spreader harness and tag out, if required. Change deflector adjustment to suit desired pattern.



Western Products
PO Box 245038
Milwaukee, WI 53224-9538
www.westernplows.com

 A DIVISION OF DOUGLAS DYNAMICS, LLC



This product conforms to EU Machinery Directive 2006/42/EC and Directive 2011/65/EC (RoHS2).

Copyright © 2018 Douglas Dynamics, LLC. All rights reserved. This material may not be reproduced or copied, in whole or in part, in any printed, mechanical, electronic, film, or other distribution and storage media, without the written consent of Western Products. Authorization to photocopy items for internal or personal use by Western Products outlets or spreader owner is granted.

Western Products reserves the right under its product improvement policy to change construction or design details and furnish equipment when so altered without reference to illustrations or specifications used. Western Products or the vehicle manufacturer may require or recommend optional equipment for spreaders. Do not exceed vehicle ratings with a spreader. Western Products offers a limited warranty for all spreaders and accessories. See separately printed page for this important information. The following are registered (®) trademarks of Douglas Dynamics, LLC: SWING AWAY®, WESTERN®.

Printed in U.S.A.