

www.storksplows.com
76048-1 Adapter Kit

Installation Instructions

76948 ADAPTER INSTALLATION

1. Install the plug-in lighting harness according to the Installation Instructions supplied with the harness kit.

2. Connect the adapter to the vehicle headlamp assembly and to the matching connector removed from the vehicle headlamp assembly.
3. Connect the adapter to the plug-in harness assembly, matching connectors as shown.

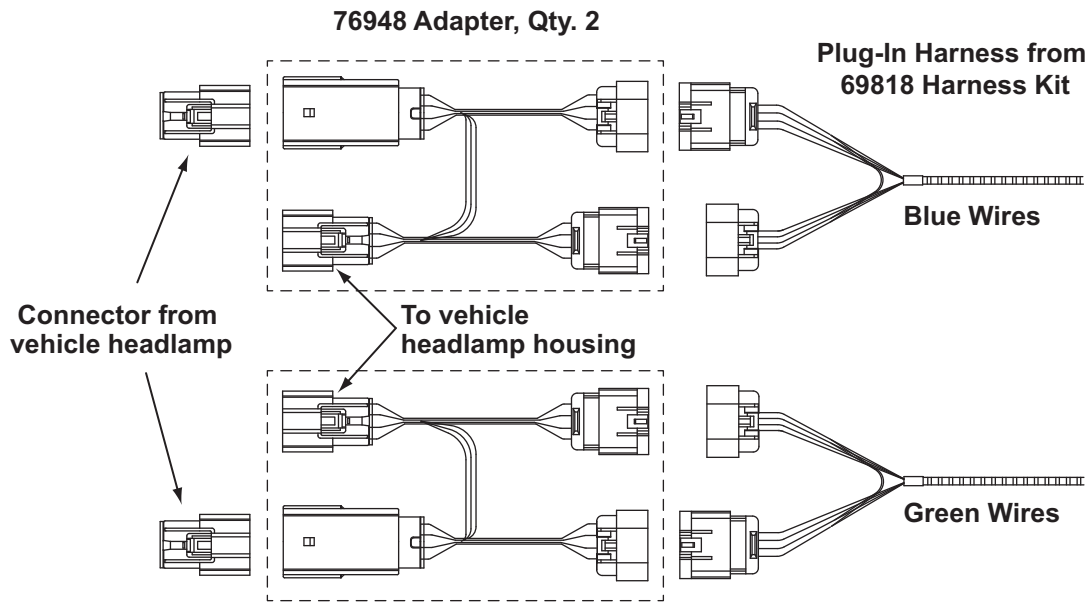

76947 ADAPTER INSTALLATION

1. Install the plug-in lighting harness according to the Installation Instructions supplied with the harness kit.

2. Connect the adapter to port "B" of the module.
3. Connect the adapter to the plug-in harness "B" connector as shown.

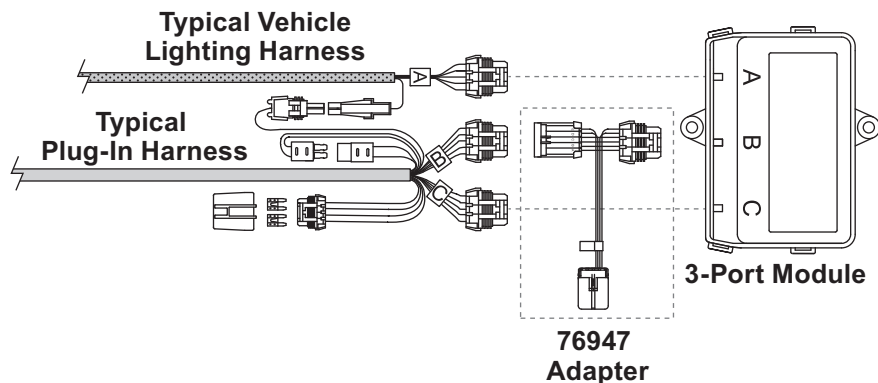

VEHICLE BATTERY CABLE EXTENSION

1. In most cases, the vehicle battery cable will not reach the vehicle battery, and 22" battery cables must be used additionally. Lay out a path for routing the vehicle battery cable from the vehicle grille towards the vehicle battery. Make sure the path avoids any hot, sharp, or moving parts of the vehicle.

⚠ CAUTION

Before drilling any holes, check both sides of the material for any wires, fuel lines, fuel tanks, etc., that may be damaged by drilling.

It may be necessary to notch or drill a hole in the plastic wall (shown) below the radiator to allow the cables to pass into the lower grille area.

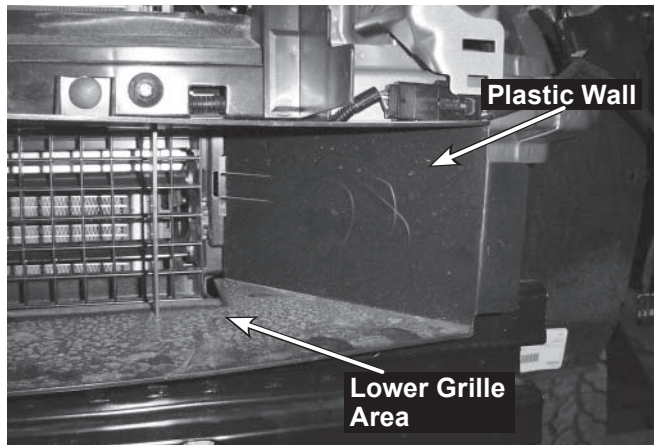

2. Mount the stud block within the range of the vehicle battery cable from the vehicle grille and the 22" battery cables, which will go between the vehicle battery and the stud block. See the illustration at right. Use the 1/4" x 3/4" cap screws, 1/4" flat washers, and 1/4" locknuts.
3. Connect one end of both the RED and BLACK 22" battery cables to the isolated stud block. Do not tighten at this time.
4. Route the unconnected ends of the 22" RED and BLACK battery cables to the vehicle battery POSITIVE (+) and NEGATIVE (-) terminals. Do not connect at this time.

The company reserves the right under its product improvement policy to change construction or design details and furnish equipment when so altered without reference to illustrations or specifications used. This equipment manufacturer or the vehicle manufacturer may require or recommend optional equipment for snow removal. Do not exceed vehicle ratings with a snowplow. The company offers a limited warranty for all snowplows and accessories. See separately printed page for this important information.

VEHICLE BATTERY CABLE INSTALLATION

⚠ CAUTION

Batteries normally produce explosive gases which can cause personal injury. Therefore, do not allow flames, sparks, or lit tobacco to come near the battery. When charging or working near a battery, always cover your face and protect your eyes, and also provide ventilation.

- Batteries contain sulfuric acid which burns skin, eyes, and clothing.
- Disconnect the battery before removing or replacing any electrical components.

1. Route the vehicle battery cable as laid out in the previous Step 1.
2. Connect the cables to the isolated studs as shown below: BLACK to BLACK at the front stud, and RED to RED at the back stud.

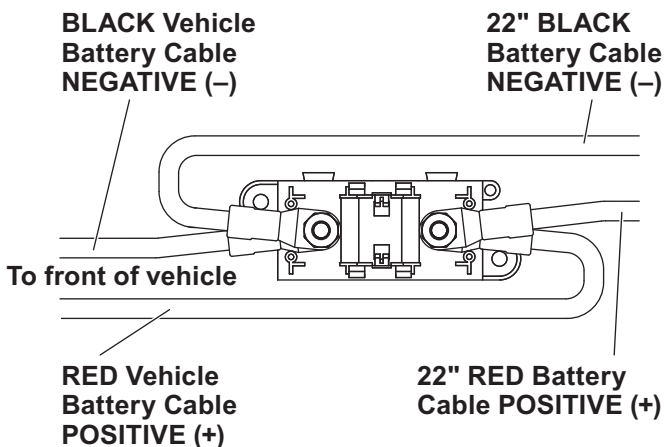

3. Torque the stud nuts to 106–159 in-lb and snap the stud block cover into place.
4. Complete the installation per instructions supplied with the plug-in lighting harness kit.