

**MAGNUM™**  
SPREADERS

## Operation and Maintenance Manual

For use with  
Magnum Anti-Icers





# Registration Data Sheet

Register your spreader at [www.magnumspreaders.com](http://www.magnumspreaders.com)



Owner Name \_\_\_\_\_

Address \_\_\_\_\_

City \_\_\_\_\_

State/Province \_\_\_\_\_ Zip/Postal Code \_\_\_\_\_

Purchased From Company Name \_\_\_\_\_

Contact Name \_\_\_\_\_

Address \_\_\_\_\_

City \_\_\_\_\_

State/Province \_\_\_\_\_ Zip/Postal Code \_\_\_\_\_

Phone Number ( \_\_\_\_\_ ) \_\_\_\_\_

E-mail \_\_\_\_\_

Date Purchased \_\_\_\_\_

Vehicle Make \_\_\_\_\_ Vehicle Model \_\_\_\_\_

Vehicle Year \_\_\_\_\_ Anti-Icer Model \_\_\_\_\_

Anti-Icer Serial Number \_\_\_\_\_

## **Thank You...**

*Thank you for buying your Magnum anti-icer. As a new owner of hard-working, mechanical equipment, we strongly urge you to spend quality time with this owner's manual. It's easy to use and full of time-saving tips that will enhance your ownership experience. It includes suggestions for faster installation, safe operation and more productive application.*

*We also strongly urge you to register your new Magnum anti-icer at [magnumspreaders.com](http://magnumspreaders.com). Registering will only take minutes and the benefits of doing so will last for years. When registered, you will receive timely and accurate communication on operation tips, maintenance, new products, and service bulletins. And in the unlikely event you need warranty work performed, your local servicing dealer will be able to process your claim faster.*

*Thanks again for your business. You can now look forward to many years of reliable performance. If you have any questions about your Magnum spreader, contact us at: [www.magnumspreaders.com](http://www.magnumspreaders.com) or call **216-486-1313**.*



*Andrew J. Outcalt*

Andy Outcalt, Magnum Spreaders, LLC.

# Table of Contents

Registration Data Sheet .....	1
Thank You .....	2
Introduction .....	4
EC Declaration of Conformity .....	4
Safety Definitions & Warnings .....	5-7
Safety Decal Locations .....	8
Anti-Icer Component Identification.....	9-11
Vehicle Loading .....	12-13
Installation / Assembly Instructions .....	14-17
Controller Operation .....	18-19
Operating Instructions.....	20-23
Electrical Schematics.....	24-25
Maintenance.....	26-29
Troubleshooting.....	30-33
Warranty .....	34

**MAGNUM™**  
SPREADERS

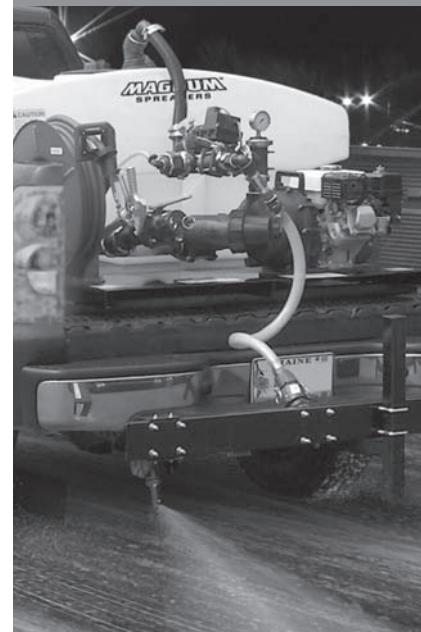

# Introduction

Snow and ice, despite the beauty it may impart to a bleak winter landscape, poses the dual threat of inconvenience and danger. The environmental conditions associated with snow and ice, not to mention the health hazards and economic loss it may impose, seriously endanger thousands of lives annually. Business and industry suffer, and millions of snowbelt residents may be affected by a single snowstorm.

Magnum Spreaders LLC has published this manual to help you get the maximum performance from your Magnum anti-icer and familiarize you with the features designed for efficiency and safety; be sure you recognize and understand them. Follow recommended operation and maintenance instructions, so when the storm hits, your Magnum anti-icer will be ready and you will know how to spread like a pro.

DO NOT EQUIP ANY VEHICLE WITH AN ANTI-ICER UNIT WITHOUT FIRST CONSULTING VEHICLE MANUFACTURERS' RECOMMENDATIONS.

Vehicles to be equipped with a Magnum anti-icer unit must meet the vehicle manufacturers' specifications, and recommendations for this use. Most vehicle manufacturers insist that vehicles which are to be used for winter maintenance be equipped with certain options and accessories, and it is so stated in the vehicle manufacturer specifications.

WARNING: Deployment of an air bag while using a Magnum anti-icer will not be covered under Magnum Spreaders' warranty. We also recommend that, for optimum performance, vehicles used for winter maintenance be equipped with:

- Four-Wheel Drive
- Minimum 60 Amp Alternator or larger
- Minimum 70 Amp Battery or larger (550 C.C.A)
- Mud and Snow Tires
- Increased Radiator Cooling

# EC Declaration of Conformity

## EC DECLARATION OF CONFORMITY

The undersigned representing the manufacturer

and the authorized representative  
established within the community

herewith declared that the Product: **Snow & Ice Equipment**

Model/Type ref.: **PV Anti-Ice Spray Systems**

is in conformity with the Essential requirements of the following EC Directives when subject to correct installation, maintenance and use conforming to its(their)intended purpose, to the applicable regulations and standards, to our operation and maintenance manual.

2006/95/EC	EC Low Voltage Directive
2004/108/EC	EMC Directive
2006/42/EC	Machinery Directive

and that the Standards and/or technical specifications referenced below have been applied:

- χ BS EN 60204-1:2006 / IEC 60204-1:2005: Safety of machinery – Electrical equipment of machines-Part 1: General requirements.
- χ EN ISO 12100-1:2003:Safety of Machinery – Basic Concepts, General Principles of Design Part 1: Basic Terminology and Methodology
- χ EN ISO 12100-2:2003:Safety of Machinery – Basic Concepts, General Principles of Design Part 2: Technical principles
- χ EN 13021:2003+A1- Winter service machines - Safety requirements
- χ EN 61000-6-2: 2005. Generic standards – Immunity for Industrial Environments.
- χ EN 61000-6-4:2005. Generic emission standard, Part 2: Industrial environment.

Year of CE Marking: 2011

Manufacturer:

Authorized Representative in the community:

Signature: *Constance Sue Strohmman*  
Position: *Product Manager*  
Date: *3/20/12*  
Place: *1146 E. 2100 S. ST. LOUIS, MO*

Signature: *Constance Sue Strohmman*  
Position: *APP*  
Date: *3/20/12*  
Place: *St. Louis, MO 61049*

OFFICIAL SEAL  
CONSTANCE SUE STROHMMAN  
Notary Public - State of Illinois  
My Commission Expires Jun 10, 2012

# Safety Definitions

These safety alert decals are used to alert you of potential personal injury hazards. Obey all safety messages that follow this symbol to avoid possible injury or death.



## CAUTION

This decal cautions all to observe general safety procedures when operating, moving, storing, cleaning or servicing this equipment.

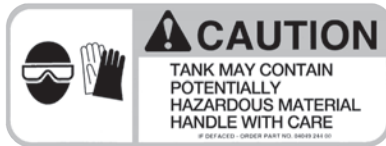

## CAUTION

This decal cautions all to the risk of the tank containing hazardous chemicals. Operators should use appropriate PPE when contact with chemicals if possible.

# Safety Definitions & Warnings

## SAFETY DEFINITIONS



This is the safety alert symbol. It is used to alert you to potential personal injury hazards. Obey all safety messages that follow this symbol to avoid possible injury or death.

### DANGER

DANGER Indicates an imminently hazardous situation which, if not avoided, will result in death or serious injury.

### WARNING

WARNING Indicates a potentially hazardous situation which, if not avoided, could result in death or serious injury.

### CAUTION

CAUTION Indicates a potentially hazardous situation which, if not avoided, may result in minor or moderate injury.











### CAUTION

CAUTION used without the safety alert symbol indicates a potentially hazardous situation which, if not avoided, will result in property damage.

1	DANGER	<b>NEVER</b> stand or ride on the anti-icer. Failure to comply will result in death or serious injury.
2	DANGER	Keep hands, feet, and clothing away from power driven parts. Failure to comply will result in death or serious injury.
3	DANGER	Make sure anti-icer is completely shut off and all movement has stopped before attempting to clean, service or unplug. Failure to comply will result in death or serious injury.
4	WARNING	<b>NEVER</b> operate or service your anti-icer without first <b>CAREFULLY</b> reading the Owner's Manual. It is <b>CRITICAL</b> for your safety to <b>ALWAYS</b> obey <b>EVERY</b> warning in the manual and follow <b>EVERY</b> instruction <b>EXPLICITLY</b> . Failure to comply could result in death or serious injury.
5	WARNING	Never leave operator's position without first completely turning off anti-icer, disengaging PTO, shutting off hydraulic valve and setting vehicle parking brake. Failure to comply will result in death or serious injury.
6	WARNING	Never operate anti-icer without all shields, guards, and safety decals in place. Failure to comply will result in death or serious injury.
7	WARNING	Anti-icer may contain potentially hazardous materials. Never operate or service your anti-icer without wearing the appropriate PPE. Refer to chemical manufacturer's MSDS for proper PPE recommendations.
8	WARNING	Anti-icer should only be operated by personnel trained in the safe use and transportation of this equipment.
9	WARNING	The anti-icer should <b>NEVER</b> be used for any other purpose other than applying ice melting or traction products on streets, parking lots and driveways. Failure to comply will result in property damage, death or serious injury.
10	WARNING	Inspect anti-icer mounting components and fasteners for wear and damage before and after each use. Worn or damaged components or fasteners could allow anti-icer to break free from the transport vehicle. Failure to comply will result in death or serious injury.
11	WARNING	Transport vehicle must not be operated when overloaded. In all cases, the loaded vehicle weight, including the entire anti-icer system, all aftermarket accessories, driver, passenger, options, nominal fluid levels, and cargo must not exceed the front/rear Gross Axle Weight Rating (GAWR), and total Gross Vehicle Weight Rating (GVWR). These weights ratings are specified on the safety compliance certification label on the driver's side door opening. Failure to comply will result in death or serious injury.
12	WARNING	Anti-icer may tip over or fall. Anti-icer should be solidly supported when being mounted, dismantled, moved, or stored. Failure to comply will result in death or serious injury.
13	WARNING	Operator, bystanders and pets should be kept at least 50 feet away from Anti-icer during operation. Failure to comply will result in death or serious injury.
14	WARNING	Engine exhaust contains lethal fumes. Breathing these fumes, even in low concentrations, can cause death. Never operate engine in an enclosed area without venting the exhaust to the outside. Failure to comply will result in death or serious injury.

# Safety Definitions & Warnings

**MAGNUM™**  
SPREADERS

15	 <b>WARNING</b>	Gasoline is highly flammable and gasoline vapor is explosive. Never smoke while working on vehicle or anti-icer. Keep all open flames away from gasoline tank and lines. Wipe up any spilled gasoline immediately. Failure to comply will result in death or serious injury.
16	 <b>WARNING</b>	<b>NEVER</b> operate the anti-icer gasoline engine without first CAREFULLY reading the Owner's Manual. It is CRITICAL for your safety to ALWAYS obey EVERY warning in the manual and follow EVERY instruction EXPLICITLY. Failure to comply will result in death or serious injury.
17	 <b>CAUTION</b>	A driver's first responsibility is the safe operation of the vehicle. The most important thing you can do to prevent a crash is to avoid distractions and pay attention to the road. Wait until it is safe to operate mobile communication equipment such as cell phones, two way radios, etc. Failure to comply will result in injury.
18	 <b>CAUTION</b>	Vehicle must conform to all local, state, and national regulations regarding the use of reflective markings and flashing lights. Failure to comply will result in injury.
19	 <b>CAUTION</b>	Batteries normally produce explosive gases which can cause personnel injury. Therefore, do not allow flames, sparks or lit tobacco to come near the battery. When charging or working near a battery, always cover your face and protect your eyes, and also provide ventilation. Batteries contain sulfuric acid which burns skin, eyes, and clothing. Failure to comply will result in injury.
20	 <b>CAUTION</b>	Installation of an anti-icer may affect your new vehicle warranty. Before beginning anti-icer installation verify mounting method is acceptable to your vehicle manufacturer. Failure to comply will result in property damage.
21	 <b>CAUTION</b>	Warranty does not apply to an anti-icer product which has been negligently or improperly assembled or installed. Failure to comply will result in property damage.
22	 <b>CAUTION</b>	<b>CAUTION:</b> To avoid harm to vehicles electrical system always disconnect battery before beginning installation. DO NOT BURN holes or WELD vehicle frame. This may cause frame failure. Failure to comply will result in property damage.
23	 <b>CAUTION</b>	<b>CAUTION:</b> To avoid harm to anti-icer electrical system always disconnect vehicle battery before beginning installation or service. Do not operate anti-icer with a missing, discharged or dead vehicle battery. Failure to comply will result in property damage.
24	 <b>CAUTION</b>	The anti-icer electrical system contains several automotive style fuses. If a problem should occur and fuse replacement is necessary, the replacement fuse must be of the same type and amperage as the original. Installing a fuse with a higher rating can damage the system and could cause a fire. Failure to comply will result in property damage.
25	 <b>CAUTION</b>	Anti-icer is not designed to be chassis or skid mounted. Anti-icer must be installed directly onto truck bed. Failure to comply will result in property damage.

## SAFETY DEFINITIONS



This is the safety alert symbol. It is used to alert you to potential personal injury hazards. Obey all safety messages that follow this symbol to avoid possible injury or death.



**DANGER** Indicates an imminent hazardous situation which, if not avoided, will result in death or serious injury.



**WARNING** Indicates a potentially hazardous situation which, if not avoided, could result in death or serious injury.



**CAUTION** Indicates a potentially hazardous situation which, if not avoided, may result in minor or moderate injury.



**CAUTION** used without the safety alert symbol indicates a potentially hazardous situation which, if not avoided, will result in property damage.

# Safety Decal Locations

These safety alert decals are used to alert you of potential personal injury hazards. Obey all safety messages that follow the symbol to avoid possible injury or death.

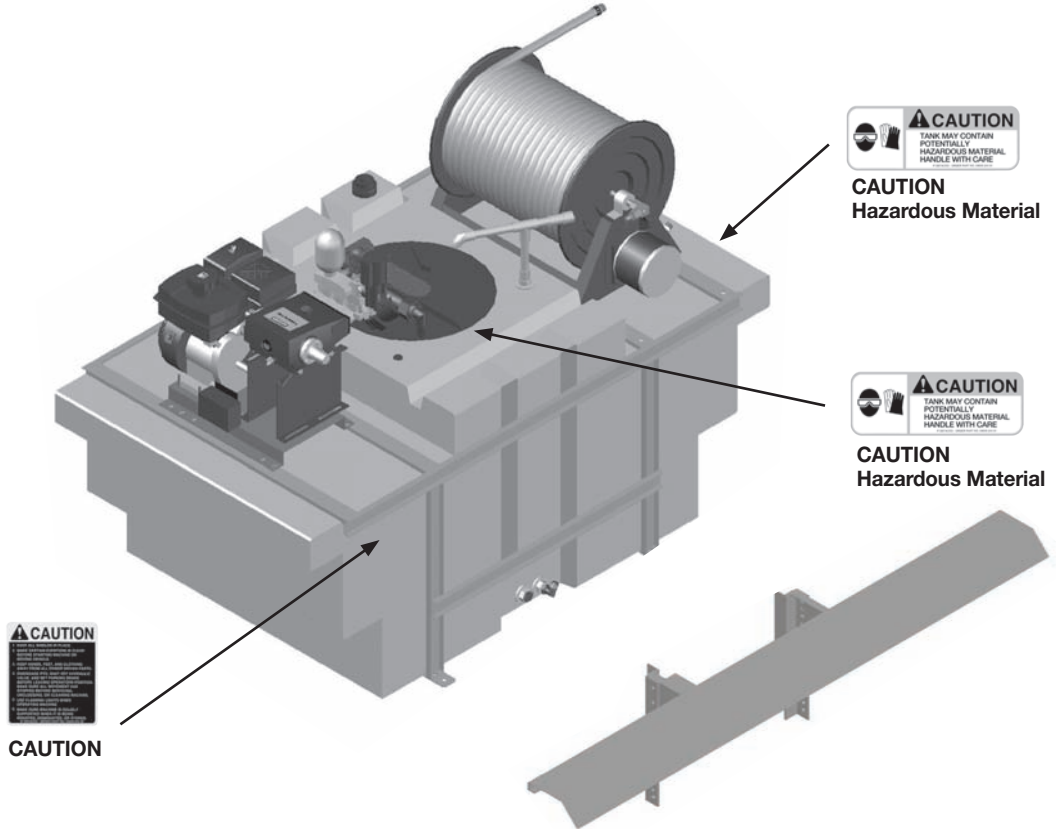

# 100 Gallon Anti-Icer Component Identification

**MAGNUM™**  
SPREADERS

- 1. Tank** – Holds liquid being applied, includes suction, return/agitation ports, and a locking lid with vent.
- 2. Gasoline Engine** – Supplies power to drive pump.
- 3. Pump** – Piston type pump receives power from gasoline engine.
- 4. Spray Boom** – Two nozzle boom mounts directly to anti-icer.
- 5. Spray Gun** – Optional spray gun allows liquid to be manually applied to small or hard to reach areas. Spray gun is supplied with various nozzles.
- 6. Hose Reel** – Optional hose reel contains either 150' or 300' of hose. Hose reel can be manual or electric rewind.
- 7. Wireless Controller** – Controls engine start, stop, and choke functions.
- 8. Valve** – Shuts off the flow of liquid to the spray boom.
- 9. Suction Strainer** – Protects the pump by filtering debris from the liquid.
- 10. Pressure Gauge** – Indicates system operating pressure.
- 11. Regulator Knob** – Increases or decreases system operating pressure.
- 12. Pressure Bypass Lever** – Relieves system pressure and returns liquid back to tank.

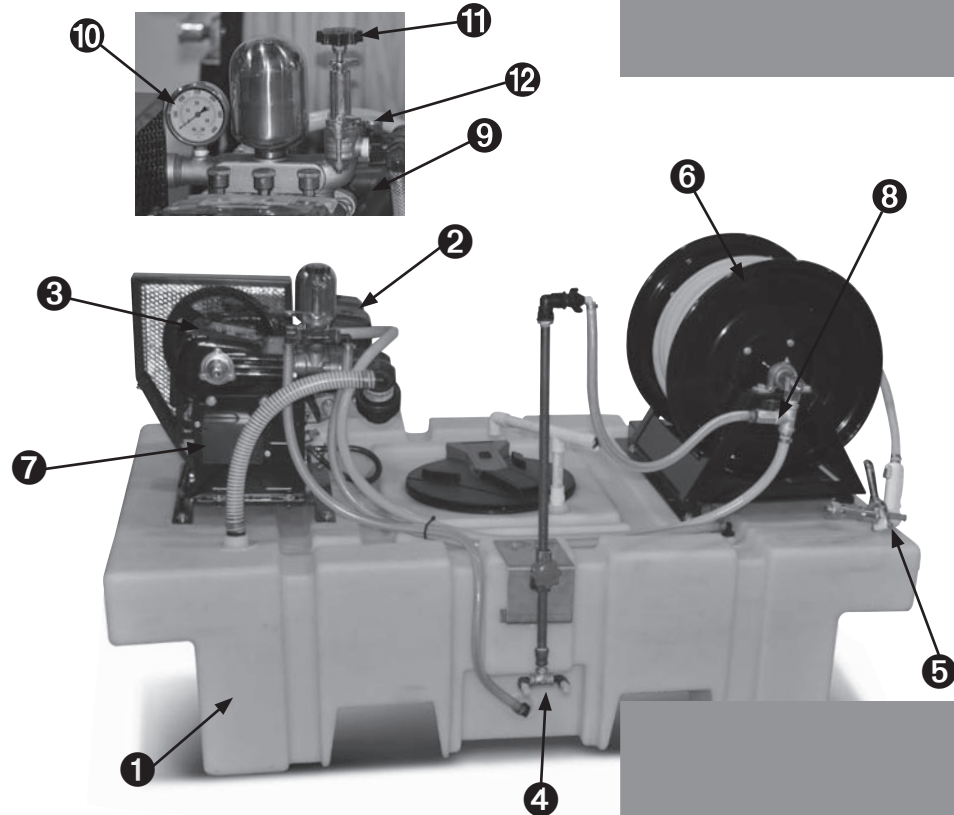

# 200 Gallon Anti-Icer Component Identification

- 1. Tank** – Holds liquid being applied, includes suction, return / agitation ports, and a locking lid with vent.
- 2. Gasoline Engine** – Supplies power to drive pump.
- 3. Pump** – Piston type pump receives power from gasoline engine.
- 4. Spray Boom** – Mounts into vehicle hitch receiver and contains five sets of nozzles.
- 5. Spray Gun** – Optional spray gun allows liquid to be manually applied to small or hard to reach areas. Spray gun is supplied with various nozzles.
- 6. Hose Reel** – Optional hose reel contains either 150' or 300' of hose. Hose reel can be manual or electric rewind.
- 7. Wireless Controller** – Controls engine start, stop, choke, and electric valve.

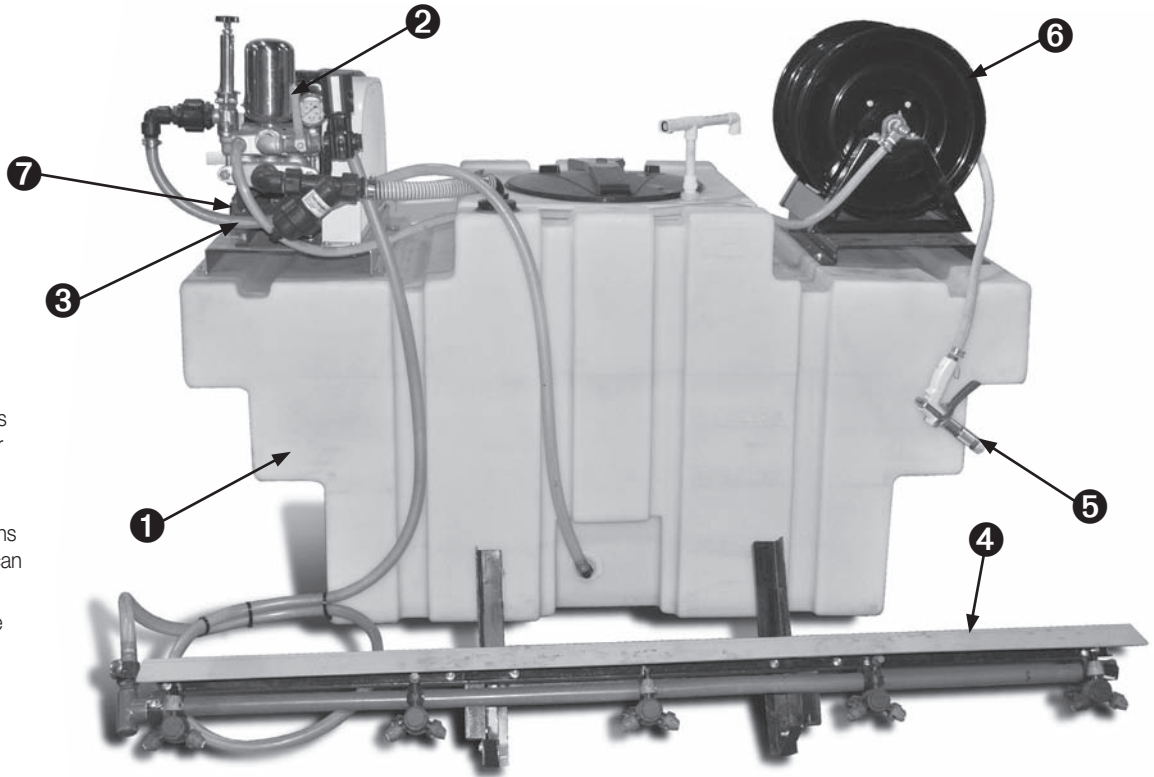

# 200 Gallon Anti-Icer Component Identification

**MAGNUM™**  
SPREADERS

- 8. **Valve** – Shuts off liquid flow to the electric valve.
- 9. **Electric Valve** – Starts and stops the flow of liquid to the spray boom.
- 10. **Suction Strainer** – Protects the pump by filtering debris from the liquid.
- 11. **Pressure Gauge** – Indicates system operating pressure.
- 12. **Regulator Knob** – Increases or decreases system operating pressure.
- 13. **Pressure Bypass Lever** – Relieves system pressure and returns liquid back to tank.

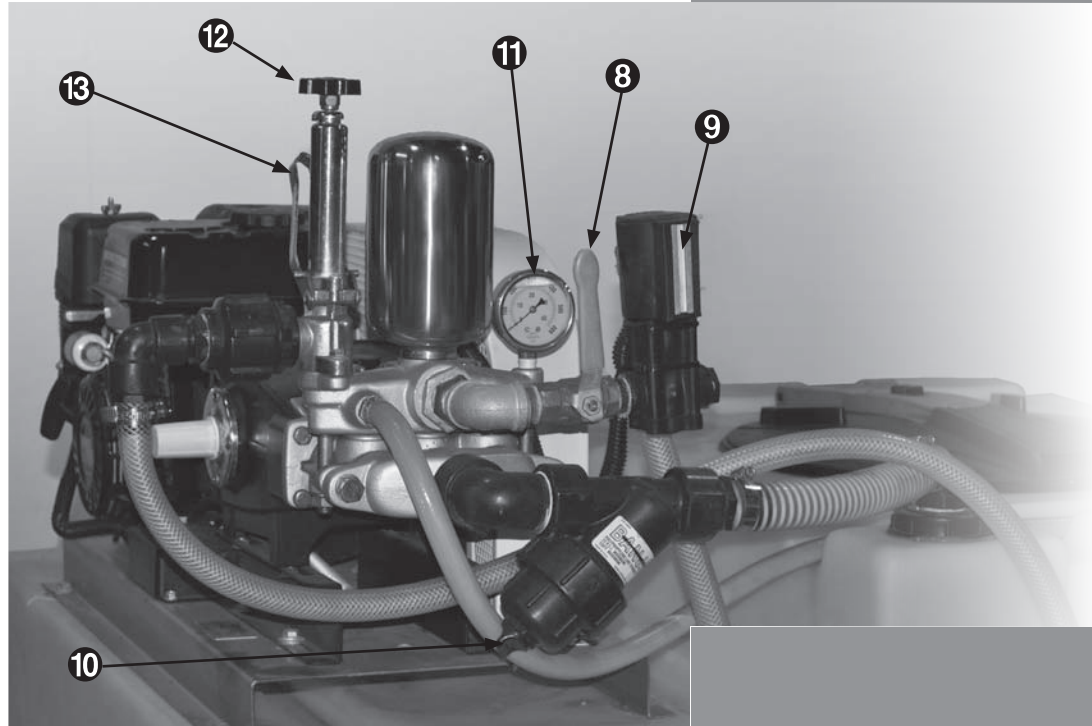

# Vehicle Loading

## Determining Vehicle Payload

It is necessary to calculate the available material payload to prevent overloading the vehicle. Overloading the vehicle can create dangerous stability and braking problems. Always consult and follow vehicle manufacturer's weight ratings and mounting instructions.



1. Mount complete anti-icer onto the vehicle.
2. Attach all additional equipment onto vehicle such as snow plow, hitch, etc that will be used when anti-icer is mounted on vehicle.
3. Fill fuel tanks.
4. With normal operator(s) inside of vehicle, weigh vehicle to obtain the Gross Vehicle Weight (GVW).
5. Obtain Gross Vehicle Weight Rating (GVWR), Front Gross Axle Weight Rating (FGAWR), and Rear Gross Axle Weight Rating (RGAWR) from the driver's door jam or from the vehicle manufacturer.
6. Subtract the GVW from the GVWR to obtain the available material payload.
7. Obtain the density (or weight) of the liquid to be applied per gallon.
8. Divide the payload by the liquid density to determine the maximum volume of liquid that can be carried by the vehicle.
9. Fill the anti-icer with liquid to the calculated volume.
10. Weigh vehicle to verify vehicle does not exceed GVWR, FGAWR, or RGAWR.
11. Repeat procedure for each type of liquid to be applied.

# Vehicle Loading

**MAGNUM™**  
SPREADERS

## 200 Gallon Vehicle Mounting Tabs

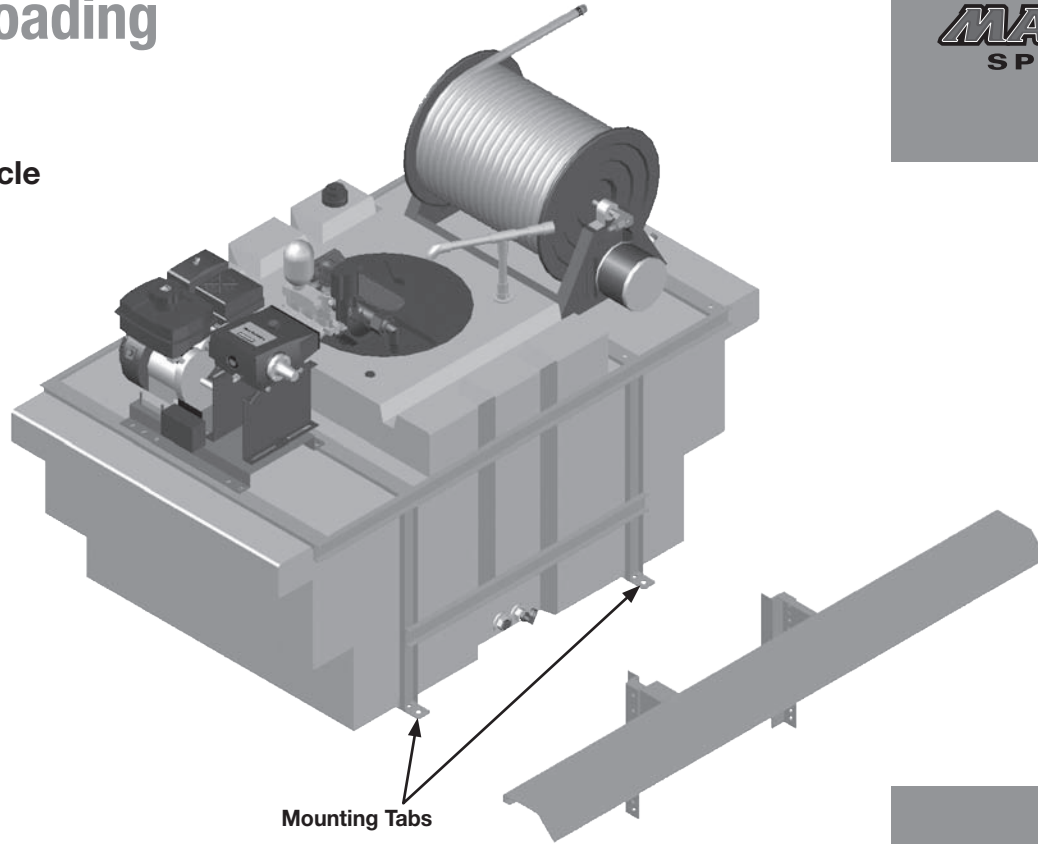

Mounting Tabs

# Anti-icer Installation / Assembly Instructions



## Vehicle Preparation

1. Turn off vehicle engine, set parking brake, and remove keys.
2. Remove trailer hitch.

## Anti-icer Preparation

1. Unpack spray boom, cargo bar, and installation kit from anti-icer.
2. Remove anti-icer unit from shipping skid.

## Lifting Anti-icer

The anti-icer unit is intended to be lifted with a forklift. Forklift must be of an adequate weight rating to support entire spreader including any additional or optional equipment that may be installed. Never attempt to lift or move a spreader with liquid in the tank.

## Anti-icer Installation

The anti-icer unit should be mounted so the bottom of the tank is sitting directly on the vehicle bed. Shipping skid is intended to be removed before mounting spreader. Verify mounting method is acceptable to vehicle manufacturer before attempting to install anti-icer.

# Anti-icer Installation / Assembly Instructions

**MAGNUM™**  
SPREADERS

## 100 gallon anti-icer

1. Place anti-icer directly into bed of vehicle with gasoline engine towards the left side of the vehicle. Anti-icer should be pushed all the way backwards against the vehicle's tailgate.
2. Install cargo bar between the sides of vehicle bed directly in front of anti-icer tank.

## 200, 300, & 400 gallon anti-icers

1. Place anti-icer directly into bed of vehicle with gasoline engine towards the left side of the vehicle. Anti-icer should be pushed all the way forward against the front of the vehicle bed.
2. Bolt spreader to the vehicle using four 1/2" grade 5 bolts and corresponding washers and locknuts (not supplied) installed through the mounting hole located in each mounting tab and vehicle frame.
3. Install cargo bar between the sides of vehicle bed directly behind the anti-icer tank.



# Anti-icer Installation / Assembly Instructions

## Spray Boom Installation



### 100 gallon anti-icer

1. Connect supply hose to boom.
2. Loosen hand knob and adjust boom up or down to desired position.
3. Tighten hand knob.

### 200, 300, & 400 gallon anti-icers

1. Insert spray boom hitch into the vehicle's 2" hitch receiver, nozzles should be pointing down towards the ground.
2. Secure boom in hitch receiver with hitch pin (not supplied).
3. Connect supply hose to boom.

## Electrical Installation

The anti-icer must be connected to the vehicle's 12 volt electrical system for operation of the engine start, choke, and discharge valve. The anti-icer can be connected to vehicles with a positive or negative ground system.

1. Disconnect ground cable from vehicle battery.
2. Install 40 amp circuit breaker in a location near the vehicle battery away from sources of moisture and heat.
3. Cut a length of #8 wire to reach from the ungrounded terminal (usually the positive terminal) on the vehicle battery to the "BAT" terminal of the circuit breaker.
4. Attach a 3/8" ring terminal to the battery end of the wire, and a 1/4" ring terminal to the circuit breaker end.
5. Connect the wire to the vehicle battery terminal and to the circuit breaker "BAT" terminal.
6. Attach a 1/4" ring terminal to the end of the remaining wire and connect to the "AUX" terminal of the circuit breaker.
7. Route the wire from the circuit breaker to the anti-icer. The wire may be routed under the vehicle, along the frame rails, or through the firewall if necessary. Make certain wire cannot be damaged by heat, sharp edges, or moving parts.
8. Route the wire to the auxiliary solenoid. For anti-icers with electric hose reels, route the wire to the solenoid mounted on the hose reel frame.
9. Trim the wire to length and attach a 3/8" ring terminal and connect to solenoid "BAT" terminal.
10. Locate an existing fastener on the vehicle frame that can be easily removed and replaced.
11. Attach appropriate ring terminal (not supplied) to the vehicle end of the ground wire and attach to vehicle frame.
12. Attach 3/8" ring terminal to anti-icer end of the ground wire and attach to existing grounding bolt on anti-icer.
13. Reconnect vehicle battery cable to vehicle battery.
14. With gasoline engine ignition in the "OFF" position test the engine start, choke, and electric valve functions for proper operation. Do not start gasoline engine without verifying engine is properly filled with engine oil.
15. Test electric hose reel by pulling out some hose and rewinding. For vehicles with a positive ground system, it may be necessary to reverse the wires on the electric hose reel to obtain the proper direction of rotation.

**MAGNUM™**  
**SPREADERS**



# Wireless Anti-icer Control System

The wireless anti-icer controller is intended to control the start/stop, choke, and electric valve on/off functions. The control system consists of a transmitter and a receiver. The receiver is mounted on the anti-icer near the gasoline engine. The transmitter is intended to remain in the vehicle cab or with the operator.

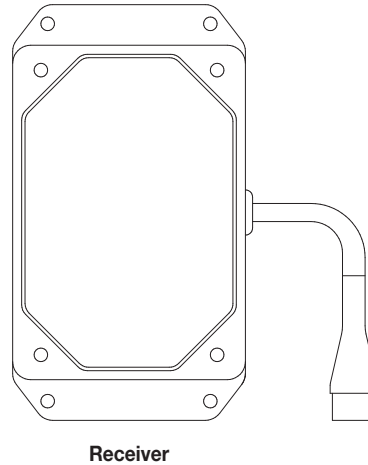
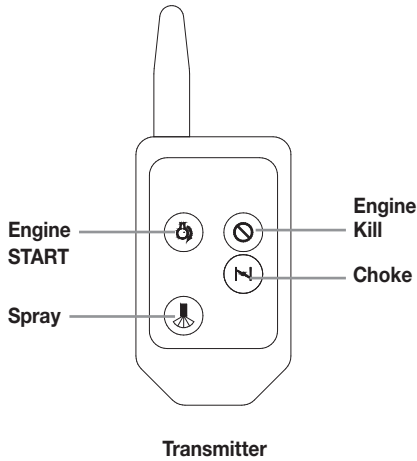

## OPERATION

1. Engage the engine choke by pressing and holding the CHOKE button.
2. Press and hold the engine START button until engine starts.  
Note: continuing to hold the engine start button after the engine starts will result in damage to the engine.
3. Once engine starts, release the CHOKE button.
4. Engage electric valve by pressing the SPRAY button once.
5. Disengage electric valve by pressing the SPRAY button a second time.
6. Engine can be stopped by pressing and holding the ENGINE KILL button until the engine stops. Note: pressing the engine kill button will also disengage the electric valve.

## SPECIFICATIONS

- 12 Volt
- Frequency 418 MHz US / 433 MHz Europe
- Transmitter battery: CR2032 Lithium Button Cell

# Wireless Gasoline Engine Control System

**MAGNUM™**  
SPREADERS

## Programming/Reprogramming Wireless Anti-icer Control System

**Tools required:** #1 Phillips screw driver, small diameter paperclip

### Programming Hand Held Transmitter

1. On the backside of the hand held transmitter depress the ADD button using a small paper clip. When the ADD button is depressed a blue LED light will flash for approximately 15 seconds.
2. While the blue LED is flashing, firmly depress each of the eight buttons on the front of the hand held transmitter one at a time. There is no certain order to depress the buttons. When the blue LED stops flashing the transmitter has been programmed.

**NOTE:** transmitter contains eight buttons but only four are marked. To program the transmitter correctly all eight buttons must be pressed one at a time before the blue LED stops flashing.

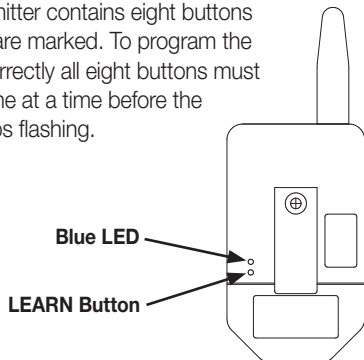

### Programming Base Receiver Unit

1. Remove the (4) screws and cover from the base receiver unit located on the anti-icer near the engine.
2. Confirm the base receiver and anti-icer control cables are connected.
3. Ensure anti-icer is connected to a 12 V power source.
4. Locate the LEARN button inside the base receiver unit and depress. When the LEARN button is depressed a red LED will flash for approximately 15 seconds.
5. While the red LED on the base receiver unit is flashing, press the SPRAY button once. When the red LED stops flashing the transmitter has been programmed to the base receiver unit.
6. Verify all anti-icer functions are operating correctly and replace base receiver cover. If programming was unsuccessful repeat programming procedure or see troubleshooting guide in this manual.



# Operating Instructions



14K-SS  
Nozzle

Stream Jet  
Nozzle



XP-20-R  
Nozzle



XP-20-L  
Nozzle



TP 11015 / TP 11020 Nozzle

## 100 Gallon Anti-icer Boom Nozzles

XP 20L	Pattern	Color	QTY	PRESSURE	30 PSI	35 PSI	40 PSI	50 PSI	N/A
	Wide Left	Yellow	1	GPM	1.4	1.6	1.8	2.0	
				LPM	5.3	6.1	6.8	7.6	
XP 20R	Pattern	Color	QTY	PRESSURE	30 PSI	35 PSI	40 PSI	50 PSI	N/A
	Wide Right	Yellow	1	GPM	1.4	1.6	1.8	2.0	
				LPM	5.3	6.1	6.8	7.6	

## 200, 300, & 400 Gallon Anti-icer Boom Nozzles

TP 11020	Pattern	Color	QTY	PRESSURE	30 PSI	35 PSI	40 PSI	50 PSI	60 PSI
	110° Fan	Stainless	5	GPM	1.7	1.9	2.0	2.2	2.5
				LPM	6.4	7.2	7.6	8.3	9.5
TP 11015	Pattern	Color	QTY	PRESSURE	30 PSI	35 PSI	40 PSI	50 PSI	60 PSI
	110° Fan	Brass	5	GPM	1.3	1.4	1.5	1.7	1.8
				LPM	4.9	5.3	5.7	6.4	6.8
1/4K-24	Pattern	Color	QTY	PRESSURE	10 PSI	20 PSI	30 PSI	40 PSI	N/A
	Wide Fan	Brass	2	GPM	2.4	3.4	4.2	4.8	
				LPM	9.1	12.9	15.9	18.2	
SJ3-20-VP	Pattern	Color	QTY	PRESSURE	20 PSI	30 PSI	40 PSI	50 PSI	60 PSI
	Stream	Black	3	GPM	1.4	1.8	2.0	2.3	2.5
				LPM	5.3	6.8	7.6	8.7	9.5

# Operating Instructions

## Anti-icer Startup

- 1. Caution:** Gasoline engine may be shipped without engine oil. Refer to engine manufacturer's instructions for proper engine oil type and filling procedure.
- 2. Caution:** Anti-icer may be shipped without oil in the pump crankcase. Fill pump crankcase with 30 weight engine oil until level reaches the full mark on pump oil sight gauge or dip stick.
- 3.** Add fuel to the gasoline engine fuel tank. Refer to the engine manufacturer's instructions for adding fuel.
- 4.** Verify gasoline engine will start and the choke, engine kill, and electric valve functions operate correctly. **Caution:** Do not allow pump to run dry for more than thirty (30) seconds.



## Anti-icer System Pressure Adjustment

### 100 gallon anti-icer units

For anti-icer units with the optional hose reel, the maximum operating pressure of the hose reel & spray gun is 600 PSI.

- 1.** Fill tank with liquid.
- 2.** Move the pressure bypass lever to the full clockwise (CW) position. This will relieve all pressure in the system and allow all liquid to be returned to the tank through the return/agitate line.
- 3.** Start engine and verify engine speed is between 3200 – 3400 RPM. For proper operation, engine needs to be operated at full speed at all times. Engine speed is set at the factory and should not require adjustment.
- 4.** Open tank lid and verify liquid is being returned to the tank through the return/agitate line.
- 5.** Unscrew and remove the regulator knob from the pressure regulator. Reinstall the regulator knob into the pressure regulator and screw in four full turns.
- 6.** Move the pressure bypass handle to the full counter clockwise (CCW) position. A slight pressure should be visible on the pressure gauge.
- 7.** Screw the regulator knob into the pressure regulator until the desired operating pressure is achieved on the pressure gauge.
- 8.** Begin discharging liquid from the spray gun by fully squeezing the handle or from the spray boom by turning the ball valve to the on position.
- 9.** Verify the desired pressure is being obtained. If needed, screw in regulator knob up to one additional turn to obtain desired pressure. If unable to achieve desired pressure refer to the troubleshooting section of this manual.
- 10.** For high pressure spray gun applications, shut off the spray boom by closing the valve located on the hose reel and perform the same procedure to obtain the desired operating pressure for the spray gun.

# Operating Instructions

## Anti-icer System Pressure Adjustment

### 200, 300, and 400 gallon anti-icer units

The electric discharge valve on the 200, 300, and 400 gallon anti-icer unit is rated at a maximum operating pressure of 100 psi. If the anti-icer is to be operated at pressures over 100 PSI, the ball valve located between the pump and electric valve must be closed to prevent damage to the electric valve. The optional hose reel and spray gun can be operated at pressures up to 600 PSI.

1. Fill tank with liquid
2. Move the pressure bypass lever to the full up position. This will relieve all pressure in the system and allow all liquid to be returned to the tank through the return / agitate line.
3. Start engine and verify engine speed is between 3200 – 3400 RPM. For proper operation, engine needs to be operated at full speed at all times. Engine speed is set at the factory and should not require adjustment.
4. Open tank lid and verify liquid is being returned to the tank through the return / agitate line.
5. Unscrew and remove the regulator knob from the pressure regulator. Reinstall the regulator knob into the pressure regulator and screw in four full turns.
6. Move the pressure bypass handle to the full down position. A slight pressure should be visible on the pressure gauge.
7. Screw the regulator knob into the pressure regulator until the desired operating pressure is achieved on the pressure gauge.
8. Begin discharging liquid from the spray gun by fully squeezing the handle or from the spray boom by turning on the electric discharge valve.
9. Verify the desired pressure is being obtained. If needed, screw in regulator knob up to one additional turn to obtain desired pressure. If unable to achieve desired pressure refer to the troubleshooting section of this manual.

For high pressure spray gun applications where the system pressure will exceed 100 PSI, fully close the ball valve between the pump and electric discharge valve and perform the same procedure to obtain the desired operating pressure from the spray gun.

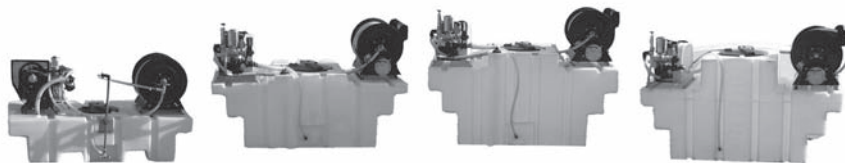

# Operating Instructions



## Anti-icer Operating Instructions

### Starting and stopping the gasoline engine

1. Fill the anti-icer with liquid.
2. Make sure gasoline engine and pump crankcase are properly filled with oil.
3. Ensure electric valve & spray gun are in the off position and move the pressure bypass lever to the full CW or up position.
4. Press and hold the START button on the hand held transmitter. If engine is cold, it may be necessary to choke the engine by pressing & holding CHOKE button.
5. To stop the gasoline engine, press and hold the engine KILL button until engine stops. Pressing the KILL button will also disengage the electric valve.

### Applying liquid with 100 gallon anti-icer spray boom

1. With gasoline engine running, move the valve to the on position and then move pressure bypass lever to the full CCW position.
2. Adjust pressure as necessary to obtain the proper flow of liquid from the spray boom nozzles.
3. To stop discharging liquid from the spray boom, move the pressure bypass lever to the full CW position and move the valve to the off position.

### Applying liquid with 200, 300, & 400 gallon anti-icer spray boom

The spray boom is equipped with five nozzle assemblies. Each nozzle assembly contains three different nozzles. Each nozzle assembly can be adjusted to utilize a different nozzle or shut off independently. See nozzle ratings chart for nozzle selection.

1. With the gasoline engine running, move the ball valve to the on position, and move the pressure bypass lever to the full down position.
2. Press the SPRAY button on the hand held transmitter one time to engage the electric valve.
3. Press the SPRAY button a second time to disengage the electric valve & stop discharging liquid from the spray boom.
4. Move pressure bypass lever to the full up position and close ball valve.

### Applying liquid with the optional hose reel and spray gun

1. Disengage locking pin from the hose reel and pull out required amount of hose.
2. With the gasoline engine running, move the pressure bypass lever to the full CCW or down position.
3. Squeeze the spray gun trigger to begin applying liquid. Release the spray gun trigger to stop applying liquid.
4. When finished applying liquid, move the pressure bypass lever to the full CW or up position and shut off engine.
5. Rewind hose into hose reel & engage locking pin.

# Electrical Schematics

## Wire Schematic for 100 Gallon Anti-icer

### Noise & Vibration Reduction

To reduce the amount of noise and vibration produced by the anti-icer:

1. Keep all mechanical fasteners, guards, and parts tight and in their proper location.
2. Maintain engine exhaust system per engine manufacturer's recommendations.

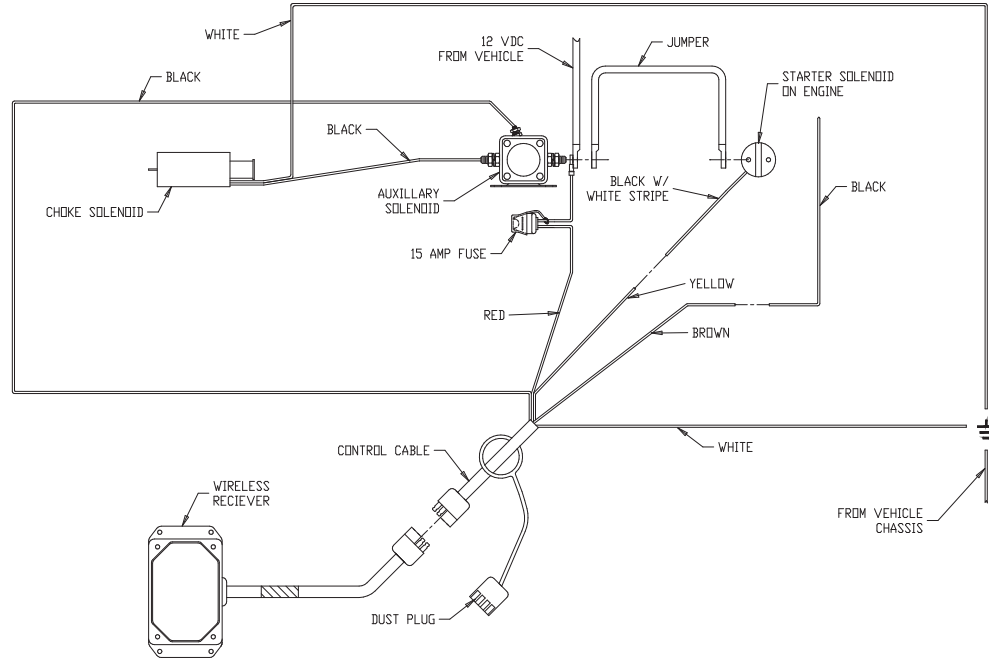

## Wire Schematic for 200, 300 and 400 Gallon Anti-icer

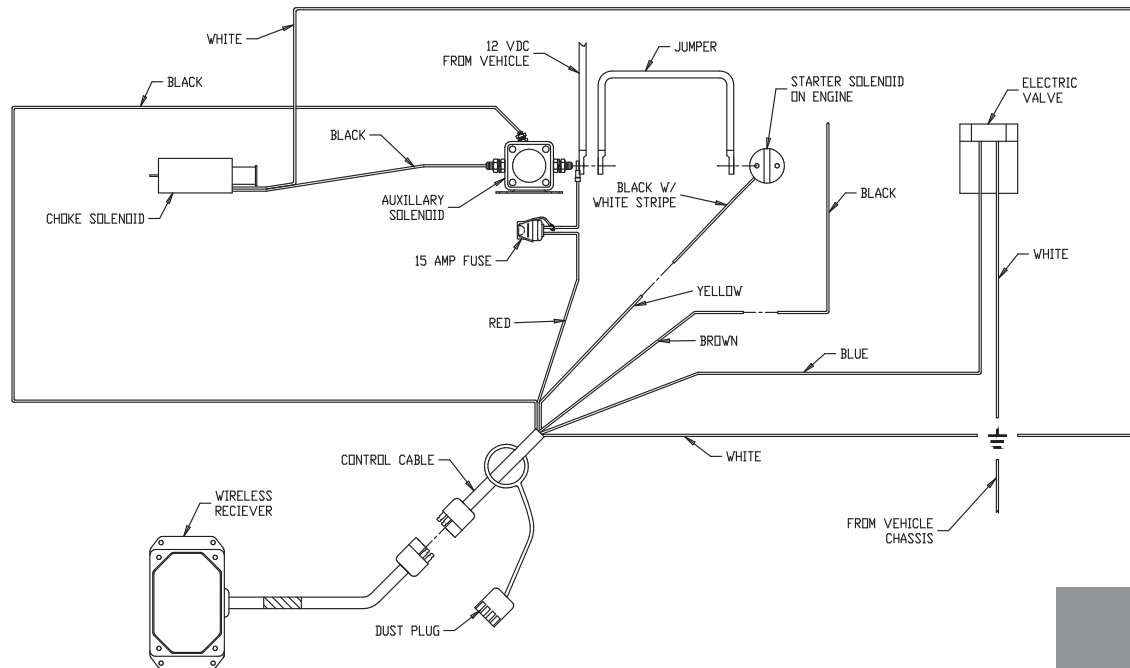

# Maintenance

Scheduled vehicle maintenance should be performed as recommended by the manufacturer.

## Vehicle Maintenance

Don't forget that in addition to keeping equipment in order:

1. Keep windshield wipers, heaters and lights working.
2. Use emergency flashing lights for increased visibility/safety.
3. Equip vehicle with tire chains where necessary.
4. Provide operators with protective clothing and gloves for handling snow and ice melting chemicals.

## Vehicle Electrical System

For maximum efficiency, the vehicle supporting the anti-icer must be properly serviced. The system should consist of at least a 70amp/hr battery and a 60 amp alternator. Be sure to check regularly:

1. Battery terminals to assure they're tight and free of corrosion.
2. Electrical connections, to assure they're tight and corrosion free.
3. Battery must be in top operating condition.
4. Alternator and regulator, to assure maximum electrical output.

## Anti-icer

Prior to the start of the winter season the pre-season maintenance should be performed to ensure the anti-icer operates reliably. Follow the maintenance schedule for service recommendations.

## Don't forget to do the following:

1. Verify anti-icer unit is securely attached to the vehicle.
2. Inspect anti-icer for loose, missing, or damaged parts, guards, or hardware.
3. Repaint any rusty parts.
4. All moving parts are free and not corroded.
5. If anti-icer was winterized prior to being stored, follow the instructions below for removing anti-freeze solution.

**Removing Anti-freeze Solution:** If anti-icer was winterized prior to storage, the anti-freeze solution will need to be removed before the first use. Anti-freeze and ammonia based cleaner must be properly disposed of per their manufacturer's instructions.

1. Start the engine and run pump until all anti-freeze solution has been pumped out of the system.
2. Fill the tank with clean water and one bottle of ammonia based cleaner.
3. Run the pump until the cleaning solution has been pumped out.
4. Refill tank with clean water only and run pump until system is dry.
5. Anti-icer is now ready for use.

# Maintenance

## General Maintenance

**Inspection:** Before and after each use, anti-icer should be inspected for loose, missing, or damaged mounting hardware, parts, or safety guards. Anti-icer should also be inspected to ensure it is securely attached to the vehicle.

**Cleaning:** Empty all liquid from anti-icer after each use. Wash entire anti-icer unit with soap and warm water.

**Drive V-belt tension:** The drive v-belt tension should be checked every ten (10) hours of operation or weekly. For optimum performance the belts should be tensioned so there is approximately 1/4"– 5/16" deflection midway between the pulleys.

**Crankcase Oil:** Check the pump crankcase oil level every ten (10) hours of operation. Crankcase should be filled with 30 weight engine oil until level reaches full mark on indicator or dipstick. Crankcase oil should be changed every one hundred (100) hours of operation.

**Cylinder Lubrication:** Each cylinder is equipped with a grease cup to prevent premature plunger and packing wear. Each cup must be filled with grease at the initial startup of the anti-icer, and then after every ten (10) hours of operation or weekly thereafter.

**Electrical System:** Electrical system should be inspected for loose connections and corrosion every ten (10) hours of operation or weekly. Dielectric grease should be applied to all electrical connections.

**Gasoline Engine:** Follow the engine manufacturer's service and maintenance recommendations.

### Wireless Remote Transmitter Battery

**Replacement:** Wireless controller transmitter battery should be replaced before the start of each season. It is also recommended to keep a spare battery with the vehicle. Wireless transmitter requires a standard CR2032 lithium button cell battery.

1. Gently press and slide off the battery cover from the wireless transmitter.
2. Remove the battery by sliding it out from underneath the retainer. Do not attempt to remove the battery by lifting it up from the retainer.
3. Install new battery by sliding it under the retainer. Battery must be installed with the positive (+) symbol visible.

**MAGNUM™**  
SPREADERS

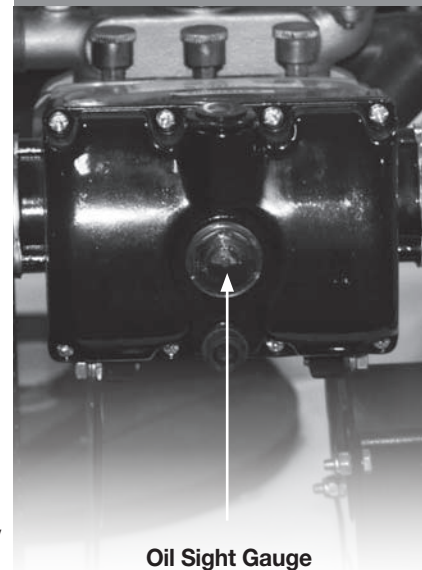

Oil Sight Gauge

# Maintenance

## Post Season Maintenance & Storage

At the end of the winter season, perform the post-season maintenance as listed in the maintenance service schedule to prevent costly repairs at the start of the next season. Also don't forget to:

1. Flush anti-icer with clean water.
2. Thoroughly wash entire anti-icer with warm soap and water.
3. Winterize the anti-icer if it will be exposed to freezing conditions. Follow engine manufacture's storage recommendations.

**Anti-icer Winterization:** If anti-icer will be exposed to freezing conditions, it will need to be winterized to prevent costly repairs. Damage caused by liquid freezing inside tank, pump, spray boom, etc. will not be covered under warranty.

1. Run the pump until all liquid is pumped out of the system. **Caution:** Do not run the pump dry for longer than 30 seconds.
2. Fill the tank with clean water and then run the pump until all water is pumped out of the system.

3. Add one gallon each of antifreeze and water to the tank. Anti-freeze / water mixture should be mixed to withstand the lowest expected temperature. Refer to the anti-freeze manufactures mixing instructions for the proper ratio.
4. Start the engine and allow the pump to operate just long enough to fill the entire system with the anti-freeze solution. This is accomplished when only antifreeze solution can be seen coming out of the spray boom and spray gun. Once the system is full of anti-freeze solution, close the discharge valve and release the handle on the spray gun and allow pump to run for one minute.
5. Anti-icer is ready for winter storage.

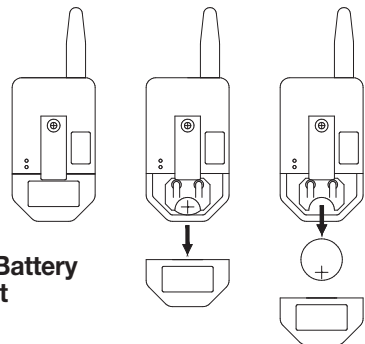

**Transmitter Battery Replacement**

# Maintenance

## Recommended Maintenance Service Schedule

Maintenance Tasks To Be Completed	Start of Season	Daily	10 Hours or Weekly	40 Hours or Monthly	End of Season
Inspect anti-icer for loose, missing, or damaged parts or hardware	X	X			X
Verify anti-icer is securely attached to vehicle	X	X			
Inspect electrical connections and apply dielectric grease to connections	X		X		X
Check pump crank case oil level	X		X		
Check grease cup level	X		X		X
Flush and refill pump crank case oil	X				
Adjust v-belts	X		X		
Oil or paint rusty surfaces	X				X
Replace wireless remote transmitter battery	X				
Engine Maintenance	As required per engine manufacturer				



# Troubleshooting Guide

## Wireless Controller Troubleshooting



Condition	Possible Cause	Possible Cause
Controller does not function	Receiver has no power	See "Receiver has no power" section
	Transmitter is not programmed to the receiver	See programming instructions
	Transmitter is defective	See "Transmitter" section
	Receiver is defective	See "Receiver" section
Receiver has no power	Receiver harness is not connected	Connect harness to anti-icer control cable
	Vehicle battery is dead or discharged	Charge or replace vehicle battery
	Fuse is blown	Replace fuse in anti-icer control cable
	Anti-icer control cable ground (white wire) is loose or corroded	Clean and tighten connection
	Receiver is defective	See "Receiver" section
Controller operates erratically	Receiver harness connection is loose or corroded	Clean and reconnect harness
	Anti-icer control cable ground (white wire) is loose or corroded	Clean and tighten connection
	Corresponding anti-icer component is defective	Replace corresponding anti-icer component
	Transmitter is not properly programmed to the receiver	See programming instructions
	Transmitter is defective	See "Transmitter" section
	Receiver is defective	See "Receiver" section

# Troubleshooting Guide

## Wireless Controller Troubleshooting

Condition	Possible Cause	Possible Cause
Transmitter does not function	Transmitter is not programmed to the receiver	See programming instructions
	Transmitter battery is dead or not installed correctly	See transmitter battery replacement instructions
	Distance between transmitter and receiver is greater than 200 feet	Reduce distance between transmitter and receiver
	Transmitter signal is being obstructed	Move transmitter to a different location
	Receiver is defective	See "Receiver" section
	Transmitter buttons are not being fully depressed	Fully depress transmitter buttons
	Multiple transmitters are being operated in the same area	Transmitters can only be operated one at a time within the same area
Receiver does not function	Transmitter is defective	See "Transmitter" section
	Transmitter is not programmed to the receiver	See programming instructions
	Receiver is defective	Replace receiver
	Receiver has no power	See "Receiver has no power" section
	Corresponding anti-icer component is defective	Replace corresponding anti-icer component
<b>Wireless Controller Notes</b>		
If red LED inside of receiver fails to light when transmitter buttons are depressed, receiver has failed and will need to be replaced.		
Multiple transmitters may be programmed to one receiver, but only one transmitter can be operated within the same air space at one time.		
The wireless controller is a rugged unit. Generally any issue can be resolved simply by reprogramming the transmitter to the receiver. ALWAYS attempt to reprogram the wireless controller before replacing any components.		



# Troubleshooting Guide

## General Troubleshooting



Condition	Possible Cause	Possible Cause
Low or lost pressure	Liquid not reaching pump	See "Abnormal Pump Suction" section
	Spray nozzle orifice too large	Replace spray nozzles
	Defective pressure gauge	Replace pressure gauge
	Defective pressure regulator	Repair or replace pressure regulator
	Worn pump suction / discharge valves	Replace pump suction and discharge valves
	Worn pump valve chamber	Replace pump valve chamber
	Plunger packings worn	Replace plunger packings
	Loose drive belts	Tighten or replace drive belts
	Pressure regulator bypass valve open	Close pressure regulator bypass valve
	Drive pulley spinning on engine / pump shaft	Replace shaft key
Abnormal Pump Suction	Suction filter clogged	Clean suction filter
	Loose suction hose	Tighten suction hose clamps
	Suction hose diameter too small	Replace with larger diameter suction hose
	Suction hose clogged	Clean suction hose
	Suction line valve closed	Open suction line valve
	Engine speed too low	Adjust engine speed to the 3200–3400 RPM range.

# Troubleshooting Guide

## General Troubleshooting

Condition	Possible Cause	Possible Cause
No liquid being discharged from spray nozzles	Discharge valve closed	Open discharge valve
	Wireless controller defective	See “Wireless Controller” section
	Tank empty	Fill tank
	Insufficient pump suction	See “Abnormal Pump Suction” section
	Boom spray nozzles in the off position or clogged	Clean boom spray nozzles and adjust to the on position
	Discharge hose clogged	Clean discharge hose
Abnormal pump noise	Insufficient liquid reaching pump	See “Abnormal Pump Suction” section
	Engine speed too high	Adjust engine speed to the 3200–3400 RPM range
	Pulley loose on engine / pump crankshaft	Replace shaft key
Abnormal pump vibration	Pulsation dampening chamber full of liquid	Empty and repair pulsation chamber
	Pulley loose on engine / pump crankshaft	Replace shaft key



# Magnum® Two Year Spreader Warranty

Magnum Spreader promises to the consumer to repair, or at our option to replace any part of this Magnum Spreader, accessory (other than noted below) except expendable parts such as pins, spreader fins, and other normal wear items, which proves to be defective in workmanship or material under normal use for a period of two years from the date of delivery to the original purchaser. During the two years, Magnum Spreader will provide, through its Distributor / Sub-Distributor network, all labor or parts necessary to correct such defects free of charge. Faulty parts will be repaired or replaced by the Distributor / Sub-Distributor where the particular piece of equipment was purchased. Any cost incurred in returning the product to the Distributor / Sub-Distributor is the responsibility of the consumer.

## Exclusions

IN NO EVENT SHALL MAGNUM SPREADER BE LIABLE FOR SPECIAL, INCIDENTAL OR CONSEQUENTIAL DAMAGES OR FOR DAMAGES RESULTING FROM A LACK OF NECESSARY MAINTENANCE, MISUSE, ABUSE, ACTS OF GOD, ALTERATION OF ANY PRODUCT, OR FROM THE USE OF PARTS NOT SUPPLIED BY MAGNUM SPREADER. USE OF THE MAGNUM SPREADER FOR ANY PURPOSE OTHER THAN SPREADING MATERIAL AS INTENDED BY MAGNUM SPREADER, IS ONE EXAMPLE OF AN ABUSE AND MISUSE OF THE PRODUCT.

## Warranty Service

In order to obtain service under this warranty, the consumer must return this product to the Distributor / Sub-Distributor from whom, the product was purchased or to any authorized Magnum Spreader Distributor / Sub-Distributor, transportation and freight charges prepaid. Only Magnum Spreader Distributors / Sub-Distributors are authorized to perform the obligations under these warranties. For the address and telephone number of the Distributor / Sub-Distributor nearest you, check the telephone directory or you may write to the warrantor at the address below.

## General

It is the responsibility of the consumer to establish the warranty period by verifying the original delivery date. A bill of sale, cancelled check or some other appropriate payment record may be kept for that purpose. For this warranty to be effective, the consumer must register the product online at [www.magnumspreaders.com](http://www.magnumspreaders.com). No person is authorized to change this warranty or create any warranty other than that set forth herein. This warranty gives you specific legal rights and you may also have other rights which vary from state to state.

In order to validate this warranty, please go to our website [www.magnumspreaders.com](http://www.magnumspreaders.com) to register your new magnum spreader.

Magnum Spreader 18513 Euclid Avenue, Cleveland, OH 44112-1084 Phone 216-486-1313



*Magnum offers a complete line of anti-icers for any application and vehicle size. Go to [www.MagnumSpreaders.com](http://www.MagnumSpreaders.com) for more information.*







**Dealer/Distributor:**

**MAGNUM<sup>TM</sup>**  
**SPREADERS**

Magnum Spreaders, LLC  
18513 Euclid Avenue  
Cleveland, Ohio 44112

**216-486-1313**

**[www.magnumspreaders.com](http://www.magnumspreaders.com)**