



Owner & Operators Manual

ECONOMIZER SPREADERS

ACE TORWEL INC.

125 DEPOT STREET, BELLINGHAM, MA 02019

Ph: 1-800-225-9415

Fx: 1-888-310-2185

www.acetorwel.com

sales@acetorwel.com

a) Economizer Hopper Body Installation

The Economizer is designed for mounting in the bed of most pick up trucks. Four hold down assemblies are provided for securing the spreader easily to the truck bed.

Reminder: Any reference to directions concerning Economizer parts or as a whole, will be designated as viewing the equipment from the rear of the vehicle as it would normally travel.

Example: Left = Driver Side
Right = Passenger Side
Front = Front of Vehicle
Rear = Rear of Vehicle

Remove the tailgate completely from the vehicle. Center the spreader to the bed of the truck and move as far forward as possible. Be sure to leave enough clearance for the material chute installation. Using the four hold down assemblies, secure the spreader to the truck bed.

Reference Figure- 9

b) Material Chute, Spinner Shaft and Spinner Disc Installation

Mount spinner shaft to output shaft of gearbox. Use (1) 5/16-18 x 2" grade 2 hex head cap screw with locknut. Mount material chute to corresponding holes located on the bottom of the left and right side plates, with the 30" rear deflector plate facing the front. Use (4) 5/16-18 x 1" hex head cap screws with flat washers, lock washers and hex nuts. Mount spinner disc on spinner shaft using (2) 3/4-10 hex nuts and (1) lock washer supplied.

Reference Figure- 3

c) Cab Side Wiring Harness Installation

Reminder: The engine side wiring for the spreader is already connected, so use care when connecting all wires and cables as a short in the system may cause damage to the engine or the spreader electrical system.

Feed the male harness cable (engine side) to the rear of the vehicle cab. If a permanent location for the harness cable is preferred, find an unobstructed area behind the cab of the vehicle and drill a 1-7/8" hole in the cab wall. A permatex sealant may be used around the contact area for a watertight seal.

Note: It is best to make a horizontal connection with the plugs, as a vertical connection will allow water and moisture to enter the plugs.

If drilling is not desired and the vehicle is equipped with a rear-sliding window, feed the exposed end of the cable (wire terminal end) under the seal to the dash. Be sure to leave enough cable at the plug end for easy connection to the male plug of the engine side cable.

Reference Figure- 7



d) Cab Mount Control Panel Installation

Connect the exposed end (wire terminal end) of the harness cable to the control panel. Make sure the ignition key on the panel is in the OFF position. Mount control panel to the underside of the vehicle dash, making sure the control panel is grounded to the vehicle.

Note: The Economizer is a self-contained unit. No outside wiring connections are necessary.

Reference Figure- 7

2. Operation Instructions**a) Cab Controls**

1. Make sure the ON/OFF switch on the engine is in the ON position.
2. Push in the ignition key (this will activate the engine choke) and turn to the ON position to start the engine.
3. Flip the conveyor switch to the ON position (the indicator light will light up) to engage operation.

Reference Figure- 7

b) Gate Height Adjustment

1. Loosen lever nut.
2. Adjust gate to desired level. (Adjusting the handle down opens the gate).
3. Tighten lever nut.

Reference Figure- 1

c) Material Chute Deflectors

1. Adjust the deflectors for desired spread pattern. Keep the flaps at the same angle.

Reminder: Lower the Flaps = Smaller spread pattern
 Raise the Flaps = Larger spread pattern.

Note: NEVER adjust the deflectors while the spinner disc is engaged.

Reference Figure- 3

d) Conveyor Chain Adjustment

1. Tighten both take-up bolts equally until chain slack is gone and chain does not ride on the base support channels. A 1" deflection or less is preferred.
2. Check that the take-up shaft is not cocked at an angle.

Note: NEVER adjust the chain while spreader is operating.

Reference Figure- 4



3. General Information

a) Safety Procedures

1. **DO NOT** operate the spreader without first reading the operations manual.
2. **DO NOT** lubricate or repair moving parts while operating the spreader.
3. **DO NOT** go into the hopper body while the conveyor chain is moving.
4. **DO NOT** refuel a hot engine or while the engine is running.
5. **DO NOT** stand directly behind the material chute while the spreader is engaged.
6. If the conveyor chain becomes clogged, **DO NOT** attempt to loosen the chain while the spreader is operating.
7. Keep hands, feet, and loose clothing away from any moving parts.

b) Storage

1. Wash unit thoroughly.
2. Oil all chains.
3. Lubricate all bearings.
4. Disconnect battery.

c) Lubrication

	<u>Location</u>	<u>Lube Type</u>
1.	Engine Oil	SAE30
2.	Engine Reduction Box	Same as Engine
3.	Take-up Bearings -E10 (2)	Bearing Grease
4.	4 Bolt Bearings - E13 (2)	Bearing Grease
5.	Driveshaft Bearings - E38 (4)	Not Needed
6.	Gear Box - EX36	ELP80/90
7.	Drive Chains - E30 & E31	Used Engine Oil
8.	Conveyor Chain - E15	Used Engine Oil

d) Service

	<u>Location</u>	<u>Recommend</u>	<u>Interval</u>
1.	Engine Oil	Check	5 Hours or Daily
2.	Engine Oil	Change	50 Hours or Season
3.	Gear Reduction Box Oil	Check or Change	100 Hours or Season
4.	Engine Oil Filter	Check or Change	100 Hours or Season
5.	Engine Fuel Filter	Check or Change	100 Hours or Season
6.	Spark Plugs (.030 Gap)	Check or Change	100 Hours or Season
7.	Harness Cable Plugs	Check Condition	50 Hours or Monthly
8.	Drive "V" Belts	Check Condition	50 Hours or Monthly
9.	Take-up Bearings	Lubricate	50 Hours or Monthly
10.	4 Bolt Bearings	Lubricate	50 Hours or Monthly
11.	Driveshaft Bearings	Check for Wear	50 Hours or Monthly
12.	Gear Box	Check Level	50 Hours or Monthly
13.	Drive Chains	Lubricate	100 Hours or Season
14.	Conveyor Chain	Check Tension	50 Hours or Monthly
15.	Conveyor Chain	Lubricate	100 Hours or Season



4. Troubleshooting**a) Engine/Electrical**

<u>Problem</u>	<u>Possible Solution</u>
1. Engine will not start	Check On-Off switch on engine (ON?) Check fuel (water in gas?) Check harness cable connections
2. Engine will not turn over	Check battery condition and connections
3. Engine will not shut off	Control panel not grounded
4. Engine smokes when running	Check air cleaner (clogged?) Check oil level (overfilled?)
5. Battery will not charge	Unit not grounded (Check Control Panel)
6. Engine will not choke	Check choke solenoid plunger
7. Choke solenoid plunger does not move	Lubricate plunger with WD40

Note: Refer to the Engine "Owners Manual" for most questions concerning Engine operation and procedures.

b) Drive

<u>Problem</u>	<u>Possible Solution</u>
1. Mag clutch will not engage	Check wire connections
2. Mag clutch will not disengage	Clutch may be seized
3. Gear box "slips"	Check "V" belts (loose?)
4. Gear box rotates slowly	Check pillow block bearing (seized?)

c) Conveyor

<u>Problem</u>	<u>Possible Solution</u>
1. Not enough material being spread	Gate not adjusted properly (open)
2. Too much material being spread	Gate not adjusted properly (close)
3. Conveyor chain has too much slack	Adjust takeup bolts in front of spreader
4. Takeup bolts are adjusted all the way in	Loosen bolts and remove links from chain

d) Spinner

<u>Problem</u>	<u>Possible Solution</u>
1. Spread pattern too short	Engine throttle set too low
2. Spread pattern too long	Engine throttle set too high
3. Spinner does not turn	Check hex nuts on shaft (tight?)
4. Spinner disc vanes wear prematurely	Check material used for rocks



5. Spreader Warranty

ACE TORWEL, INC warrants each new machine manufactured and sold by it, as well as such accessories and parts of its manufacture, to be free from defects in material and workmanship under normal use and service.

This warranty is limited to one (1) year from date of sale from factory.

The extent of its obligation under this warranty is limited to repairing or replacing at its factory (or at locations of authorized dealers) any parts that, upon examination, shall be found to have been defective.

This warranty is in lieu of all other warranties, expressed, implied or statutory, and of all other obligations or liabilities on its part, there being no implied warranty with respect to said articles, whether of suitability or otherwise.

ACE TORWEL, INC neither assumes nor authorizes any person to assume for it, any other liability in connection with the sale of said machine or accessories thereto.

This warranty shall not apply to any piece of equipment or accessory which shall have been repaired or altered in any way outside of the ACE TORWEL, INC factory or at any authorized dealer, nor to any machine or accessory which has been subjected to misuse, negligence or accident, nor for one loaded beyond its normal load capacity.

It is further understood that parts or assemblies included as part of any complete machine, such as engines, batteries, motors, pumps, etc., which are not manufactured by ACE TORWEL, INC, are not covered by this warranty, but are covered by such warranty and as prescribed by the respective manufacturers thereof.

ACE TORWEL, INC reserves the right to change any specification, design or construction, without notice or obligation.

Liability for Delays

No liability shall be attached to ACE TORWEL, INC for direct, indirect or consequential damages or expenses due to loss, damage, detention or delay in delivery of products resulting from acts or delays beyond its control.

Repair Procedure

To assure prompt handling of claims, any part failure, malfunction or repair shall be reported to the company's claim department within 30 days of failure. All parts returned to TORWEL shall be sent prepaid for warranty processing. No claim will be processed if a report is not filed within 30 days of failure or defective parts are not returned within 30 days of failure.

Claims shall be sent to:

**Ace Torwel, Inc.
125 Depot Street
Bellingham, MA 02019
Attn: Warranty Claim
Telephone (508) 987-8580
Fax: (508) 987-8550**



ECONOMIZER HOPPERS

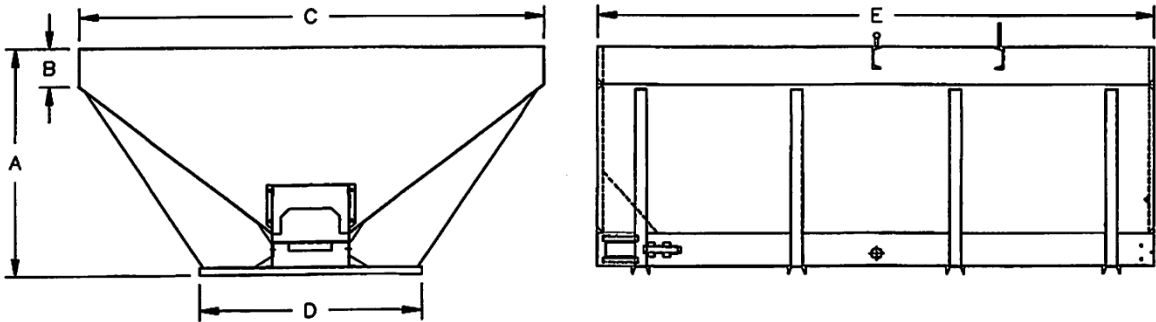

CAPACITY	A	B	C	D	E
5.0 YD	50	12	80	38	108
4.0 YD	45	7	80	38	96
3.2 YD	42	4	80	38	96

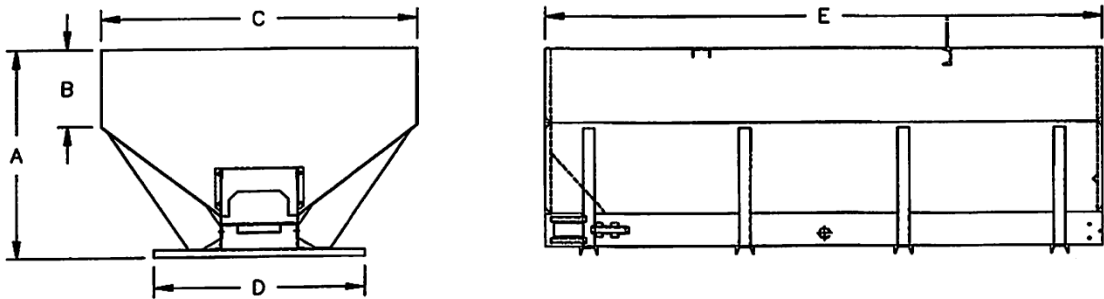

CAPACITY	A	B	C	D	E
2.5 YD	41	14	54	36	96
1.7 YD	34	7	54	36	96
1.5 YD	34	7	54	36	84
1.0 YD	34	7	54	36	60

FIG-A



Hopper Capacity	Hopper Length	Overall Length	Conv. Width	Top Width	Height	Weight	Loaded Weight
1.0 Yard	60"	88"	13"	50"	36"	850 LBS	3,850 LBS
1.3 Yard	72"	100"	13"	50"	36"	875 LBS	4,775 LBS
1.5 Yard	84"	112"	13"	50"	36"	900 LBS	5,400 LBS
1.7 Yard	96"	124"	13"	50"	36"	950 LBS	6,050 LBS
2.5 Yard	96"	124"	13"	50"	43"	1,000 LBS	8,500 LBS
3.0 Yard	108"	136"	13"	50"	43"	1050 LBS	10050 LBS
3.2 Yard - LP	96"	124"	13"	80"	55"	1,100 LBS	10,700 LBS
3.8 Yard - LP	108"	136"	13"	80"	55"	1,175 LBS	12,575 LBS
4.0 Yard - LP	96"	124"	13"	80"	58"	1,150 LBS	13,150 LBS
4.4 Yard - LP	108"	136"	13"	80"	58"	1,225 LBS	14,425 LBS
5.0 Yard - LP	108"	136"	13"	80"	60"	1,350 LBS	16,350 LBS

ECONOMIZER MODEL CODES

[1] [2] [3] - [4] [5] [6]

[1] = SPREADER TYPE

- 'E' - *ECONOMIZER* (Engine Powered Unit)
- 'H' - *HYDRASPREAD* (Hydraulic Powered Unit)

[2] = YARDAGE CAPACITY

- '10' - 1.0 Yard Capacity
- '13' - 1.3 Yard Capacity
- '15' - 1.5 Yard Capacity
- '17' - 1.7 Yard Capacity
- '25' - 2.5 Yard Capacity
- '30' - 3.0 Yard Capacity
- '32' - 3.2 Yard Capacity
- '38' - 3.8 Yard Capacity
- '40' - 4.0 Yard Capacity
- '44' - 4.4 Yard Capacity
- '50' - 5.0 Yard Capacity

[3] = POWER SUPPLY

- 'H9' - 9 HP Honda OHV Engine
- 'B2' - Dual Hydraulic Motors

[4] = HOPPER LENGTH

- '5' - 60" Length
- '7' - 84" Length
- '8' - 96" Length
- '8W' - 96" Length (Low Profile)
- '9W' - 108" Length (Low Profile)

[5] = HOPPER STEEL OPTION

- 'SS' - Stainless Steel (Type 304)

[6] = CHUTE EXTENSION

- 'L' - w/ 12" Chute Extension



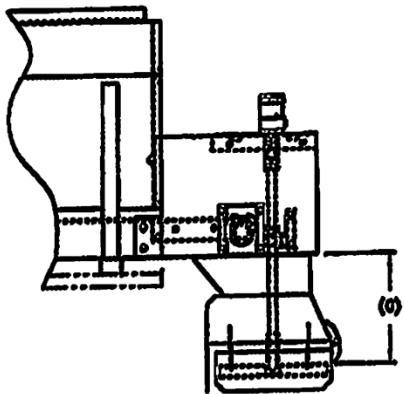
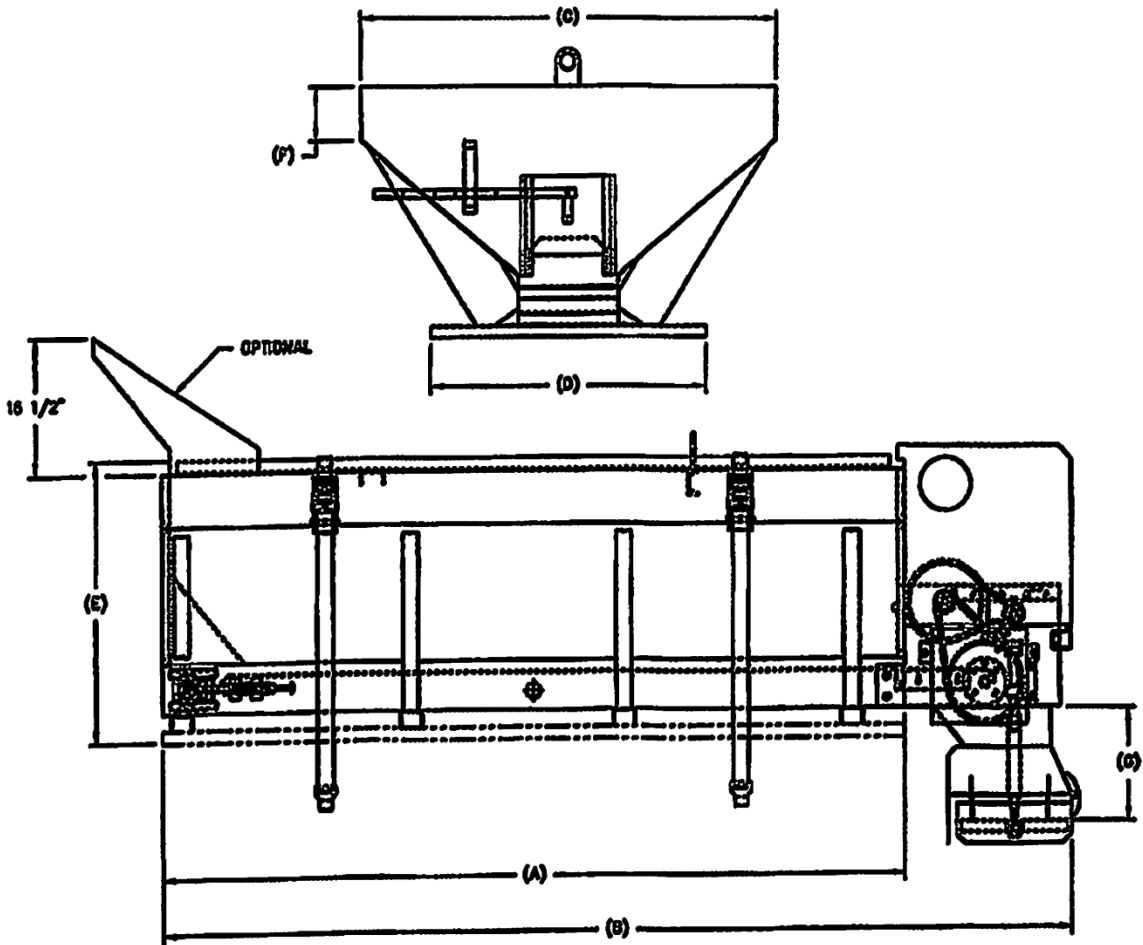

HYDRASPREAD BACK END

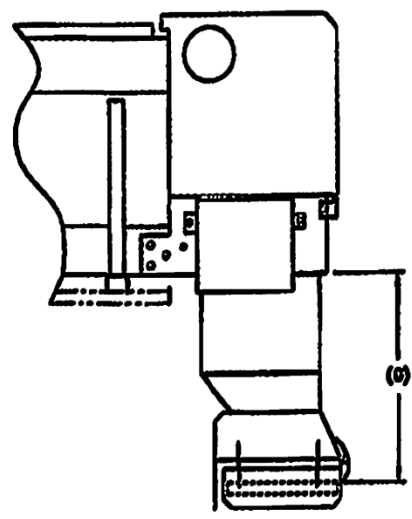

"L" OPTION

Ace Torwel Inc.
125 Depot Street,
Bellingham, MA, 02019.



PH: 1-800-225-9415
Fax: 1-888-310-2185
sales@acelorwel.com
www.acelorwel.com

E01 - HOPPER ASSEMBLY DIAGRAM

#	QTY	DESCRIPTION	PART #
1	1	RIGHT SIDE PANEL	E1-1
2	1	LEFT SIDE PANEL	E1-2
3	1	FRONT PANEL	E1-3
4	1	REAR PANEL (GATE)	E1-4
5	1	CONVEYOR BED	E1-5
6	4	BASE CHANNEL	E1-6
7	3	GUSSET, LH	E1-7L
8	3	GUSSET, RH	E1-7R
9	1	GUSSET, LH FRONT	E1-7LF
10	1	GUSSET, RH FRONT	E1-7RF
11	1	BATTERY TRAY	E1-8
13	1	LIFT CHANNEL	E1-10
14	1	CROSS BRACE	E1-11
15	4	CORNER GUSSET	E1-13
16	1	GATE GUIDE	E1-22
18	1	HANDLE GUIDE	E1-16
19	4	TAKEUP ANGLE	E1-17
20	1	LIFTING EYE	E1-18
21	1	CHAIN GUIDE	E1-20
22	1	GATE	E8-1
23	2	TAKEUP TUBE	E9
24	1	HANDLE ASSEMBLY	E60
25	1	END BRACE	E1-24
26	2	WOOD RUNNER	ERUN
27	4	LIFTING EYE (CORNER)	E1-19-17
28	8	LAG BOLT - 1/4 X 3	

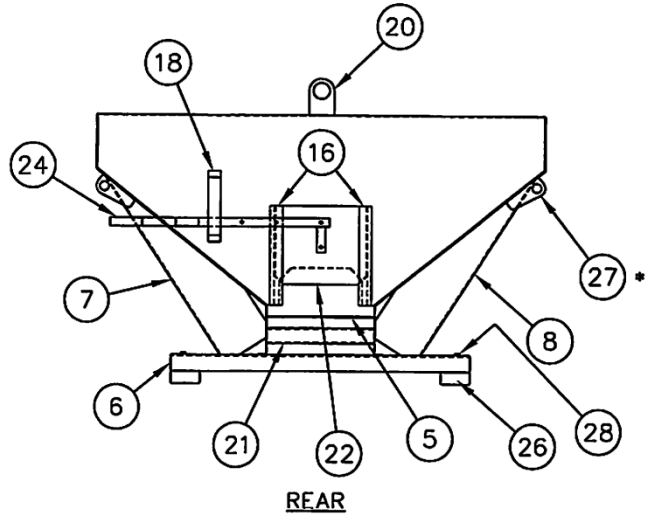

* WELD 1" IN FROM ENDS AND FLUSH TO OUTSIDE TYP.

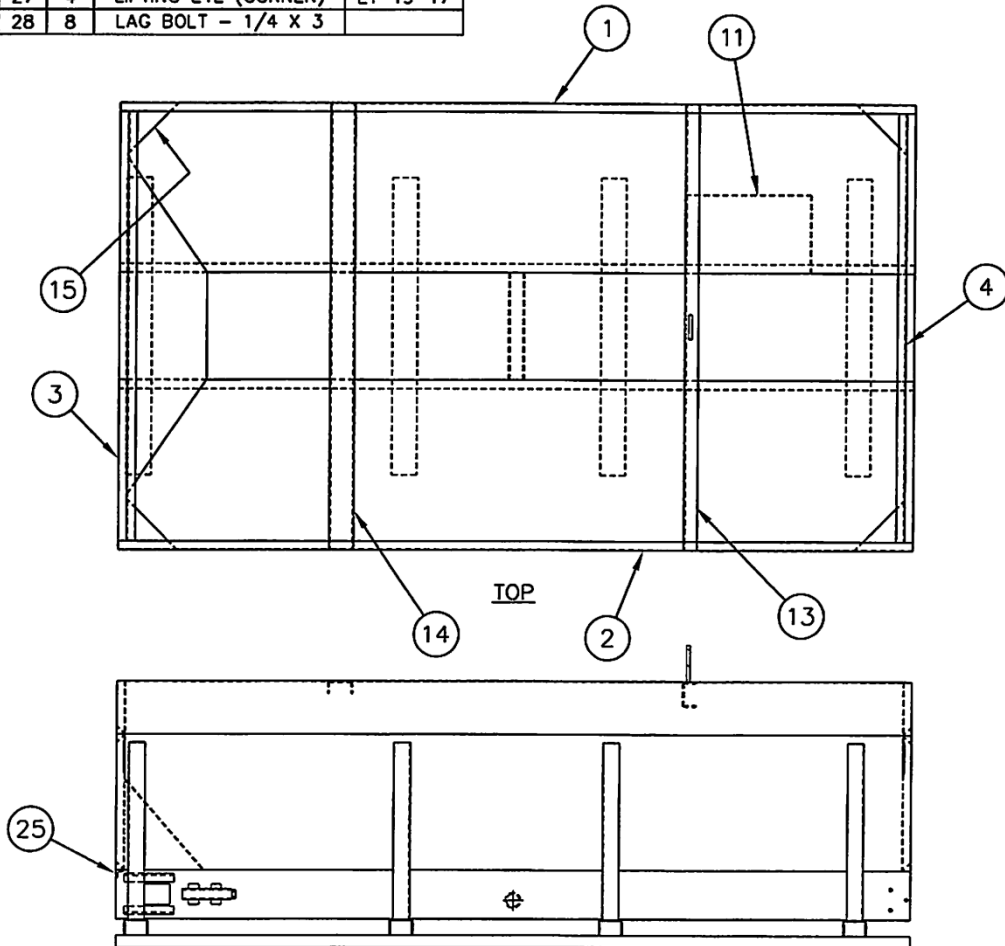

#	QTY	DESCRIPTION	PART #
1	1	MOTOR BED	E2A
2	1	LEFT SIDE PLATE	E2L
3	1	RIGHT SIDE PLATE	E2R
4	1	CHAIN DRIVE COVER	E2-4
5	1	FLOOR EXTENSION	E2-5
6	1	ENGINE COVER (HOOD)	E3
7	1	HINGE ROD	E3-10D
8	1	LEFT HINGE	E3-10L
9	1	RIGHT HINGE	E3-10R

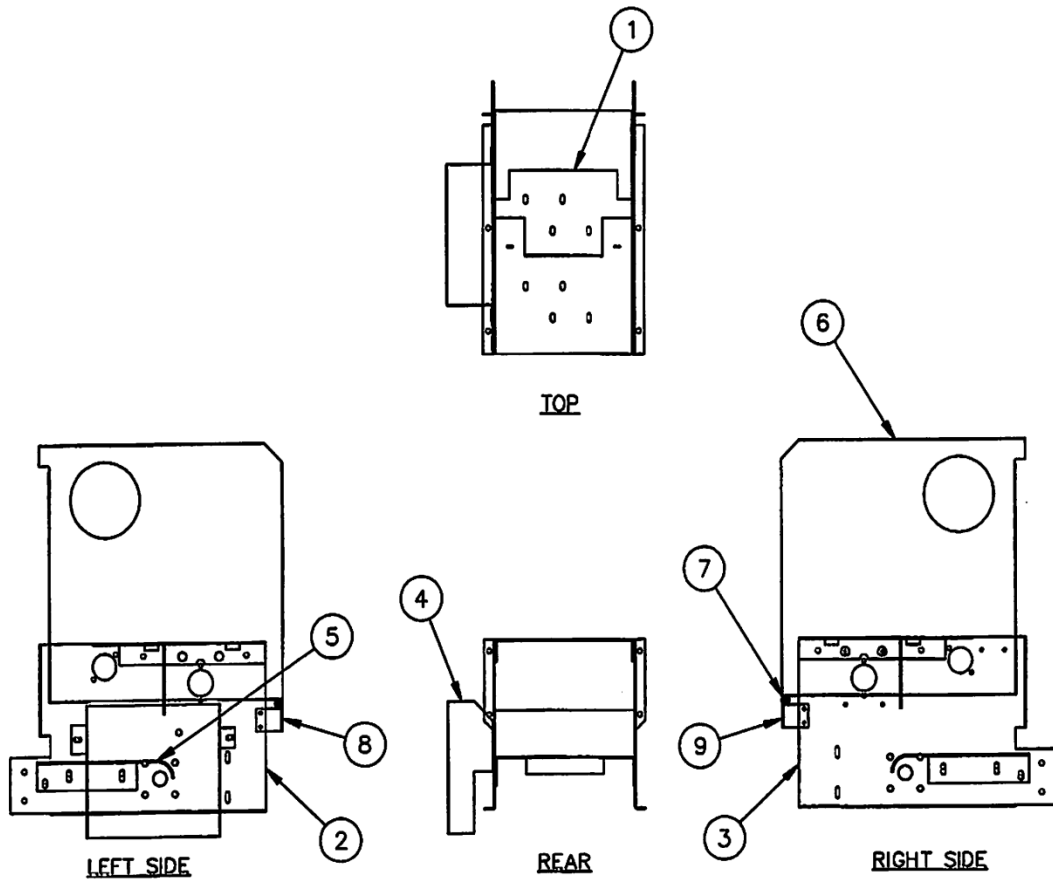
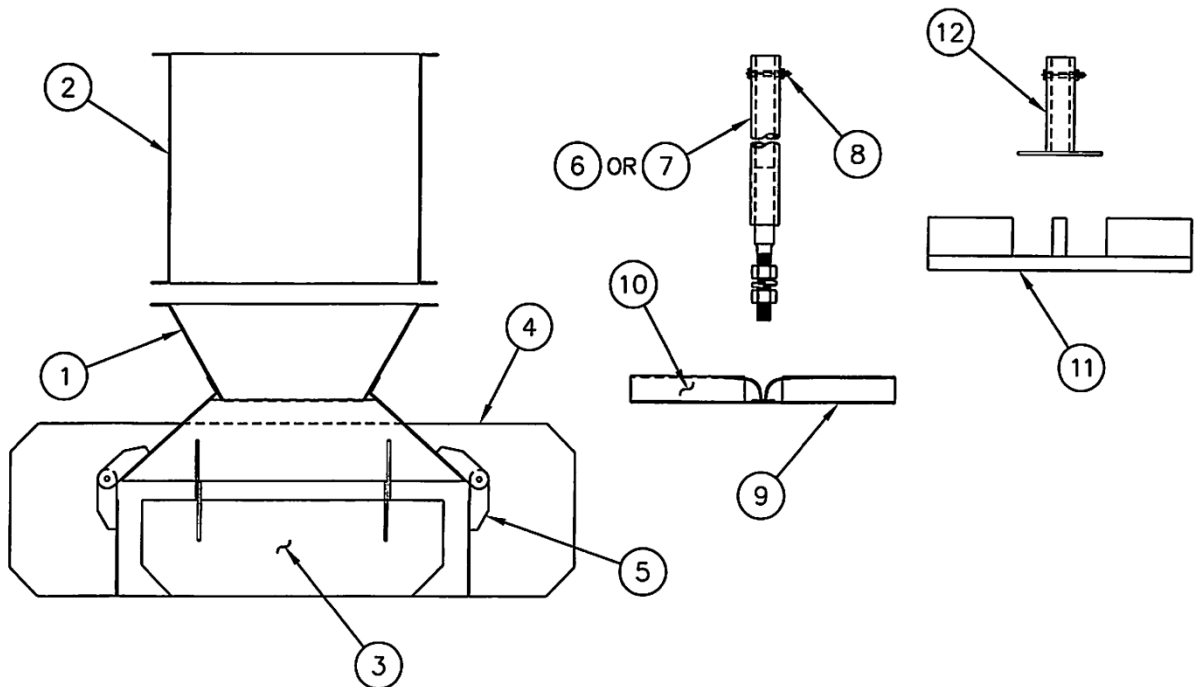

FIG-2



E03 - DISCHARGE ASSEMBLY

#	QTY	DESCRIPTION	PART #
1	1	MATERIAL CHUTE ASSEMBLY	E7
2	1	12" CHUTE EXTENSION	E7-1
3	3	MATERIAL DEFLECTOR (HINGED)	E6
4	1	REAR DEFLECTOR (FIXED)	E7-7
5	6	HINGE	E7-6
6	1	STD. SPINNER SHAFT - 14"	EX17S
7	1	LONG SPINNER SHAFT - 26"	EX17L
8	1	BOLT W/LOCKNUT	EX17SB
9	1	14" SPINNER DISC (NO HUB)	E18
10	4	SPINNER VANE	E18-2
11	1	14" POLY SPINNER DISC (NO HUB)	T220205P
N/S	1	14" POLY SPINNER DISC (W/EXT HUB)	T220205PT
12	1	EXTENDED HUB	T220204X



*ITEMS 3,4, & 5 INCLUDED WITH E7 ASSEMBLY

FIG-3

Ace Torwel Inc.
 125 Depot Street,
 Bellingham, MA, 02019.



PH: 1-800-225-9415
 Fax: 1-888-310-2185
sales@acelorwel.com
www.acelorwel.com

#	QTY	DESCRIPTION	PART #
1	2	BH RIVET (E9-2) - 5/8" X 4"	E101Z
2	2	TAKEUP SPRING - 5"	E103
3	2	TAKEUP BOLT - 5/8-11 X 5"	E104
4	2	BH RIVET - 1/2" X 1 1/4"	E106
5	4	TAKEUP TUBE	E1-17
6	2	TAKEUP ANGLE	E9
7	2	TAKEUP BEARING - 1"	E10
8	4	8 TOOTH SPROCKET - 1"	E11-CS
9	1	TAKEUP SHAFT - 1" X 17"	E12
10	2	4 BOLT BEARING - 1"	E13
11	1	CONVEYOR DRIVESHAFT - 1" X 19"	E14
12	1	CONVEYOR CHAIN	E15

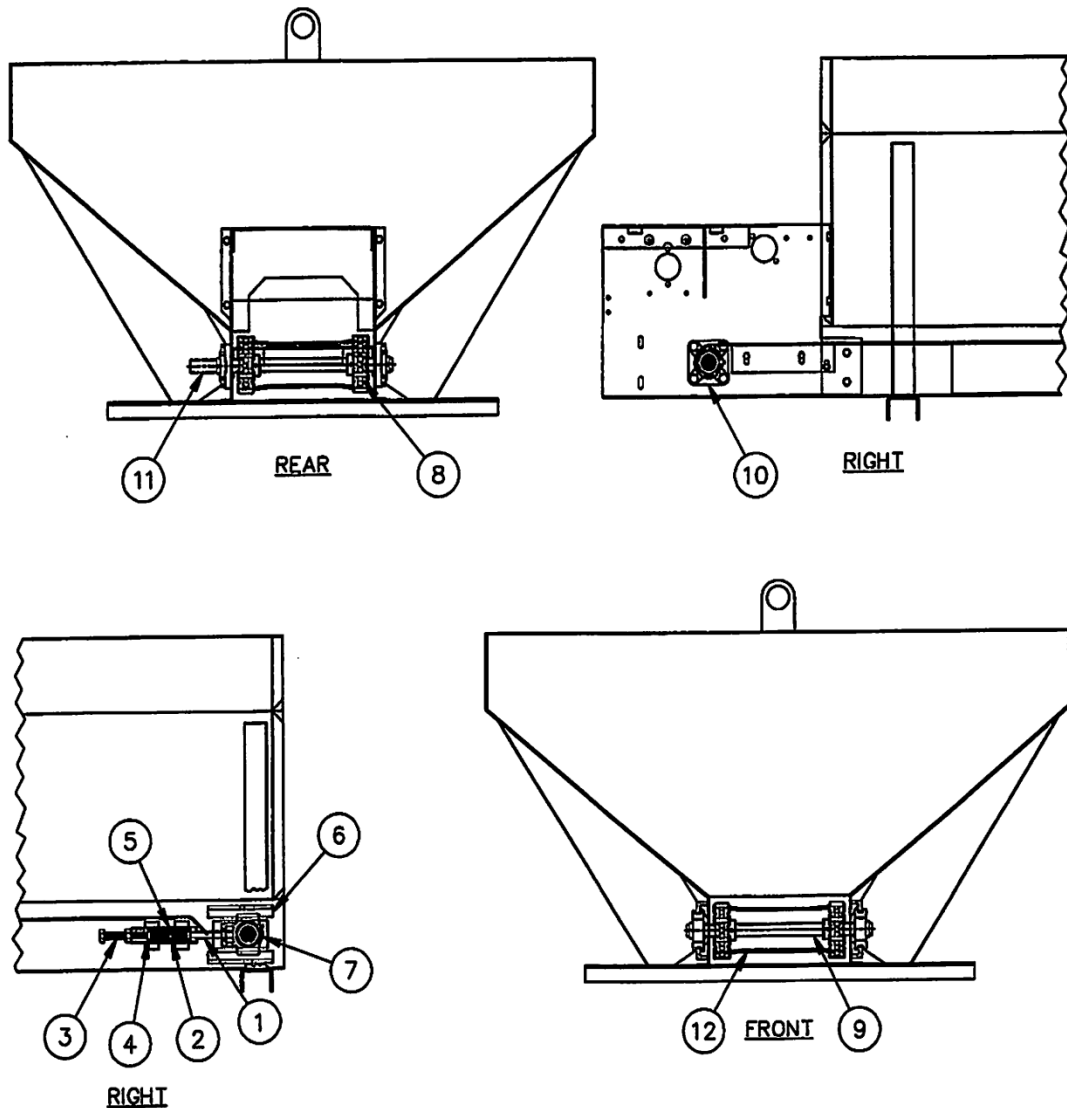

FIG-4

Ace Torwel Inc.
 125 Depot Street,
 Bellingham, MA, 02019.



PH: 1-800-225-9415
 Fax: 1-888-310-2185
sales@acelorwel.com
www.acelorwel.com

ECONOMIZER GAS HYDRAULIC PARTS

Item No.	Part Number	Part Description
----------	-------------	------------------

Conveyor Assembly - Reference Figure # 4

1	E13	4 Bolt Bearing
2	E14	Conveyor Drive Shaft
3	E15	Conveyor Chain (8 ft)
4	E11-CS	8 Tooth Cast Sprocket - 1" Bore

Take - Up Assembly - Figure # 4

1	E101Z	BH Rivet - 5/8" x 4"
2	E103	Takeup Spring - 5"
3	E104	Takeup Bolt - 5/8"-11 x 4"
4	E106	BH Rivet - 1/2" x 1 1/4"
5	E12	Takeup Shaft
6	E10	Takeup Bearing

#	QTY	DESCRIPTION	PART #
1	1	48 TOOTH SPROCKET - 1"	E16
2	1	48 TOOTH SHEAR SPROCKET - 1"	E16S
3	1	SHEAR BOLT (5/16-18 X 1.25 - GR2) W/LOCKNUT	E16SSB
4	1	MAGNETIC CLUTCH	E22
5	2	11 TOOTH SPROCKET - 1"	E26
6	1	67 PITCH DRIVE CHAIN	E30
7	1	61 PITCH INTERMEDIATE CHAIN	E31
8	1	CHAIN TENSIONER [SPROCKET]	E32-IS
9	2	MASTER LINK	E30CL
10	1	INTERMEDIATE SHAFT - 1" X 18.75"	E33
11	1	GEAR BOX - DIRECT DRIVE (DD)	EX36
12	1	GEAR BOX MOUNT BRACKET	EX36B
13	1	PILLOW BLOCK BEARING - 1"	EX36P
14	4	DRIVESHAFT BEARING W/(2) FLANGETTES & LOCK COLLAR	E38
15	1	SPINNER BRACKET	EX19
16	1	SQUARE KEY - 1/4" X 2"	E33-1
17	1	WOODRUFF KEY - 5/32" X 5/8"	E39-1
18	1	SQUARE KEY - 1/4" X 7/8"	E39-2

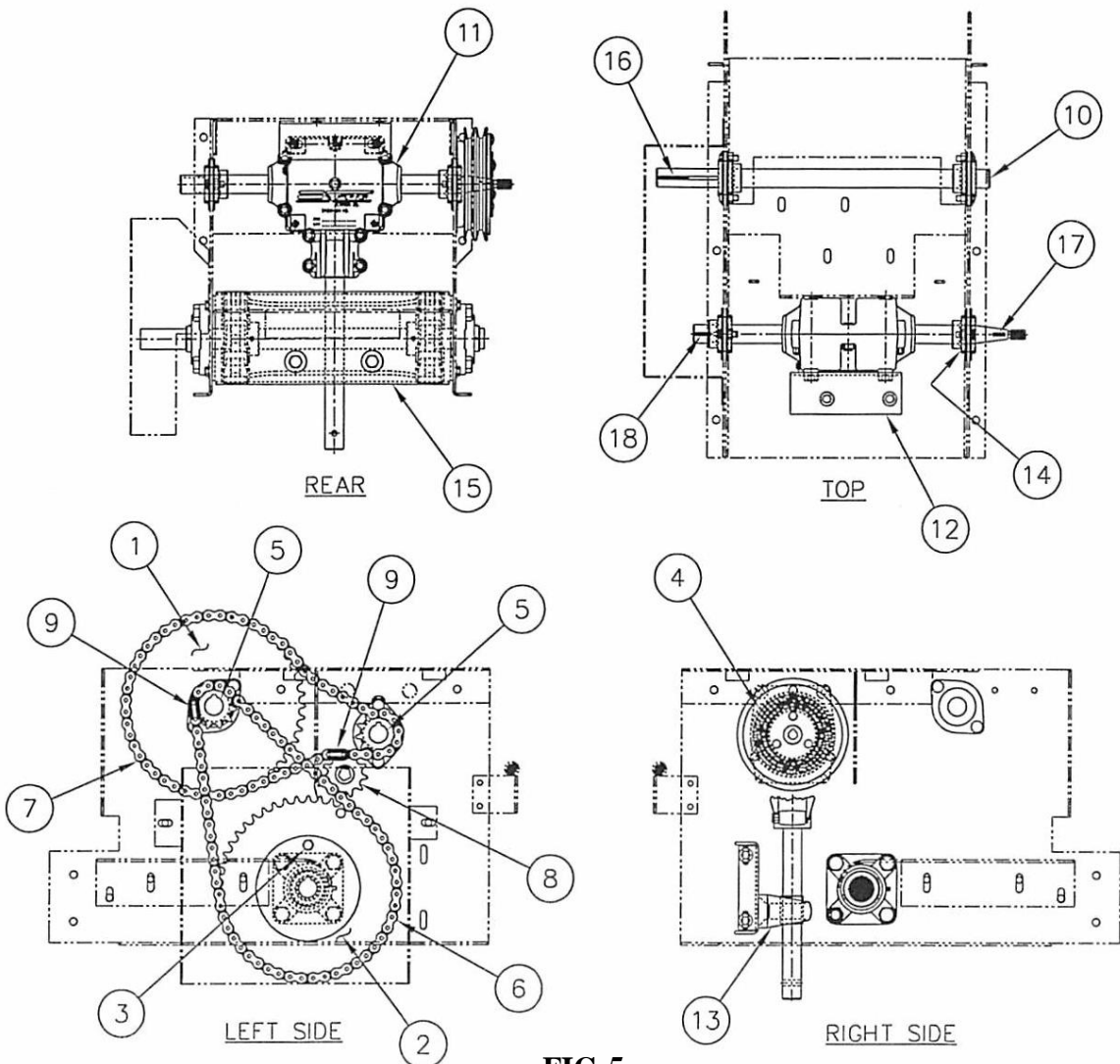
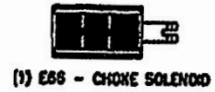

FIG-5



#	QTY	DESCRIPTION	PART #	ENG SER. #
1	1	CHOKE SOLENOID	E66	-
2	1	BRIGGS THROTTLE/CHOKE BRACKET	E80-202	202457
3	1	BRIGGS CHOKE PUSHROD	E75B-202	-
4	1	HONDA CHOKE BRACKET	E66H	S82400
5	1	HONDA CHOKE PUSHROD	E75H	-
6	1	BRIGGS THROTTLE PUSHROD	E75BT-202	-
7	1	HONDA THROTTLE BRACKET	E66HT	S82400
8	1	HONDA THROTTLE PUSHROD	E75HT	-



NOTE: WHEN REPLACING A BRIGGS ENGINE S/N 198457 WITH A S/N 202457 YOU WILL NEED TO REPLACE THE MOTOR BED ALSO. NEW MOTOR BED P/N IS E2A-202.

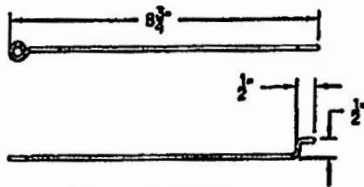

(8) E75HT HONDA THROTTLE P.R.

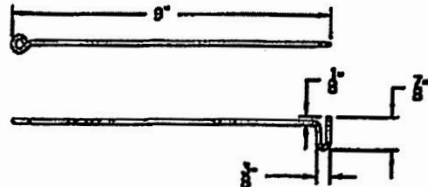

(6) E75BT-202 BRIGGS THROTTLE P.R.

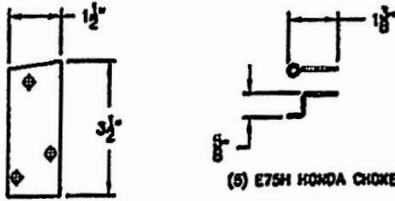

(5) E75H HONDA CHOKE P.R.

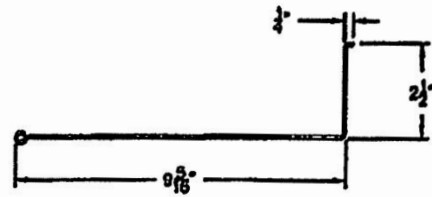

(3) E75B-202 BRIGGS CHOKE P. R.

(4) E66H HONDA CHOKE BRACKET

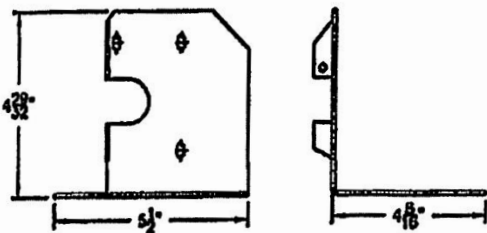

(7) E66HT HONDA THROTTLE BRACKET

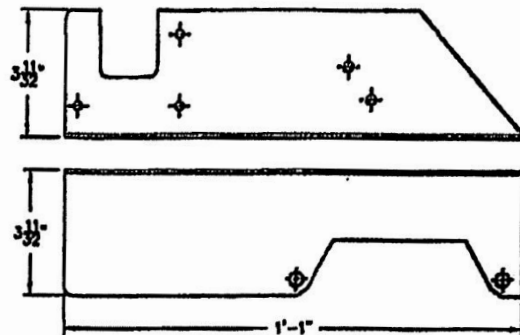

(2) E80-202 BRIGGS THROTTLE/CHOKE BRACKET

FIG-6



ELECTRIC DIAGRAM

7 WAY PLASTIC HOUSING, MECHANICAL DRIVE,
WITH THROTTLE CONTROL.

E67 (SIDE PLATE) STARTER SOLENOID

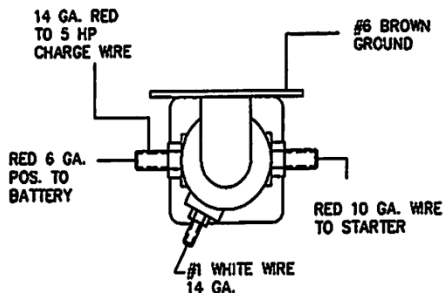

CAB CONNECTIONS

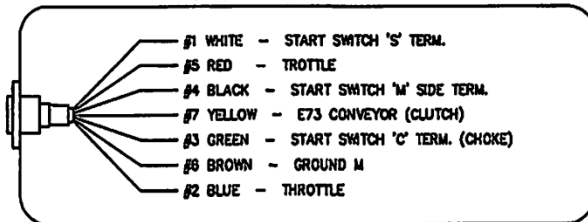

SANDER CONNECTIONS

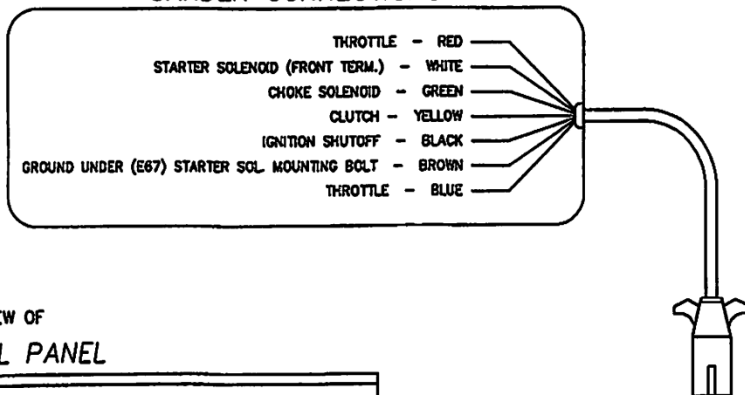

REAR VIEW OF CONTROL PANEL

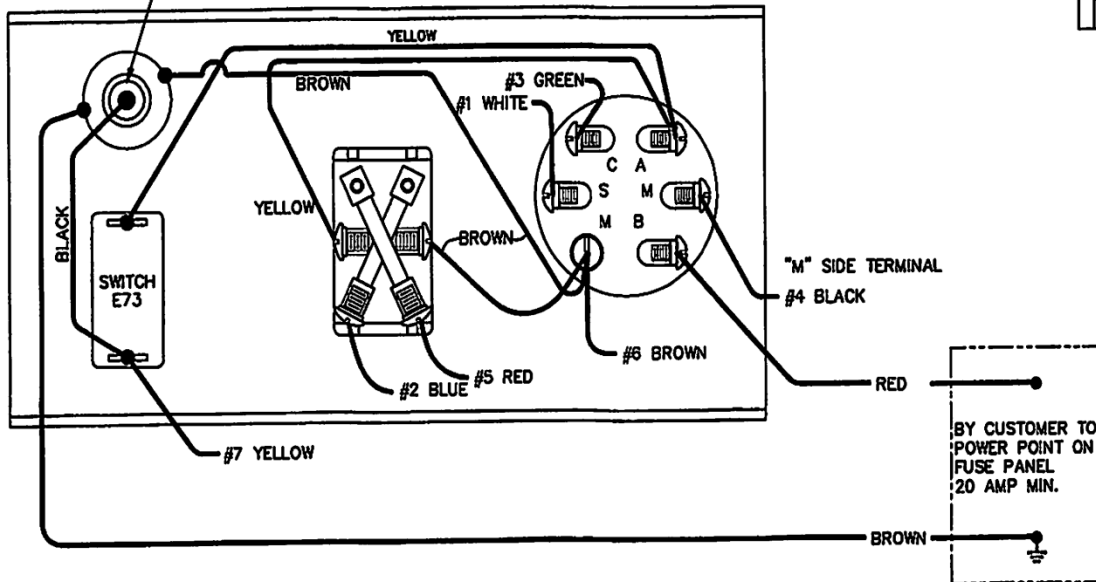

- A - ACCESSORY
- B - BATTERY
- C - CHOKE (Electric)
- M - MAGNETO
- S - START (Solenoid)

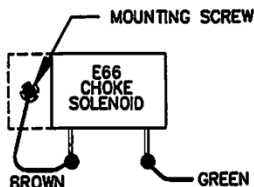
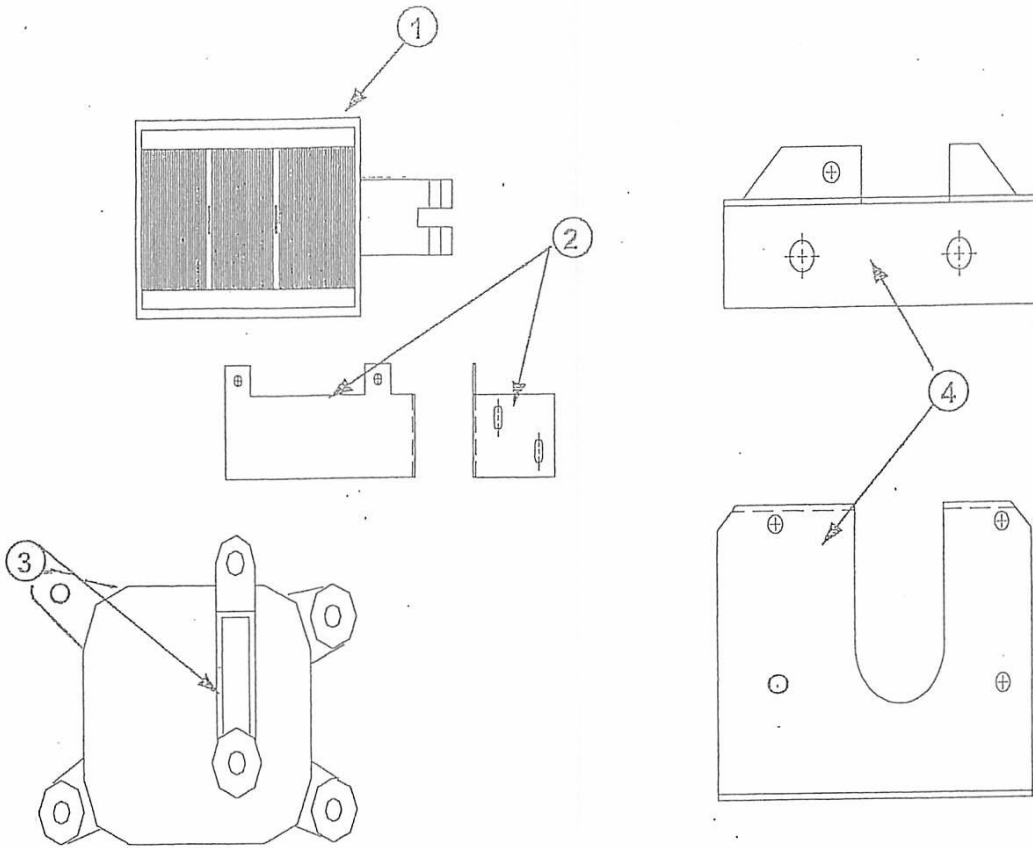

FIG-7



ECONOMIZER GAS HYDRAULIC PARTS

Item No.	Part Number	Part Description
Control Detail - Reference Figure # 7		
1	E70	Control Panel
2	EX74	Keyed Ignition Switch
3	E73T	Throttle Reversing Switch
4	E72	Pilot Light
5	E73	Conveyor On/Off Switch
6	EX44	Cab-Side Wiring Harness - 7 Way x 23'
7	EX44-1	7 Way Cab-Side Harness Plug End
8	EX43	Spreader Side Wiring Harness
9	EX43-1	7 Way Spreader Side Wiring Harness Plug End
10	E42-8U	Battery
11	E42A	Battery Box
12	E42N	Negative Battery Cable
13	E42P	Positive Battery Cable
14	E67	Starter Solenoid



Reference Fig # 8

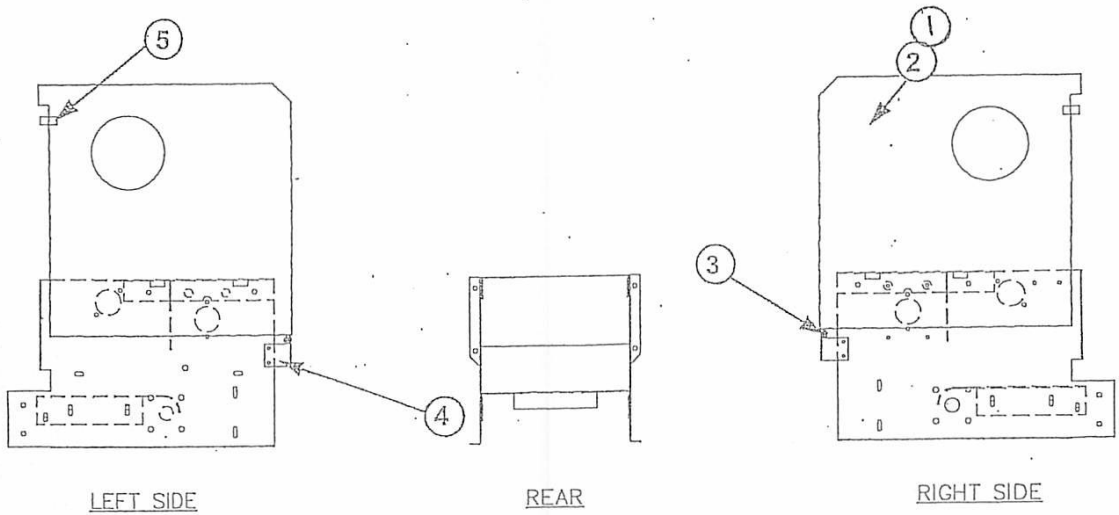

Reference Fig # 9

ECONOMIZER GAS HYDRAULIC PARTS

Item No.	Part Number	Part Description
----------	-------------	------------------

Engine Electrical Figure # 8

1	E66-D	Choke Solenoid
	EGH-E66-1	Choke Return Spring
2	EGH-C69-H	Honda Choke Bracket
3	E77C	Electric Throttle Motor, **(ACTUATOR)** (4 BOLT MOUNT)
4	EGH-C69BT	Tecumseh Throttle Bracket
	EGH-C75-5TT	Throttle Motor Push-Rod

Engine Housing Figure # 9

1	E3	Engine Cover (Hood)
2	E3S	Stainless Engine Cover (Hood)
3	E3-10D	Hinge Rod
4	E3-10	Hood Hinge
5	E3-9	Hood Latch
6	EGH-C69-H	Honda Choke Bracket
7	EGH-C69-HT	Honda Throttle Bracket
8	EGH-C75-HT	Honda Throttle Motor Push Rod
9	EGH-C75-HC	Honda Choke Push Rod
10	EGH-C25-H	5.5 HP Honda Engine Only
11	EGH-C25-HON	5.5 HP Honda Engine Assembly
12	EGH-C75-TC	Choke Rod (Tecumseh Engine)

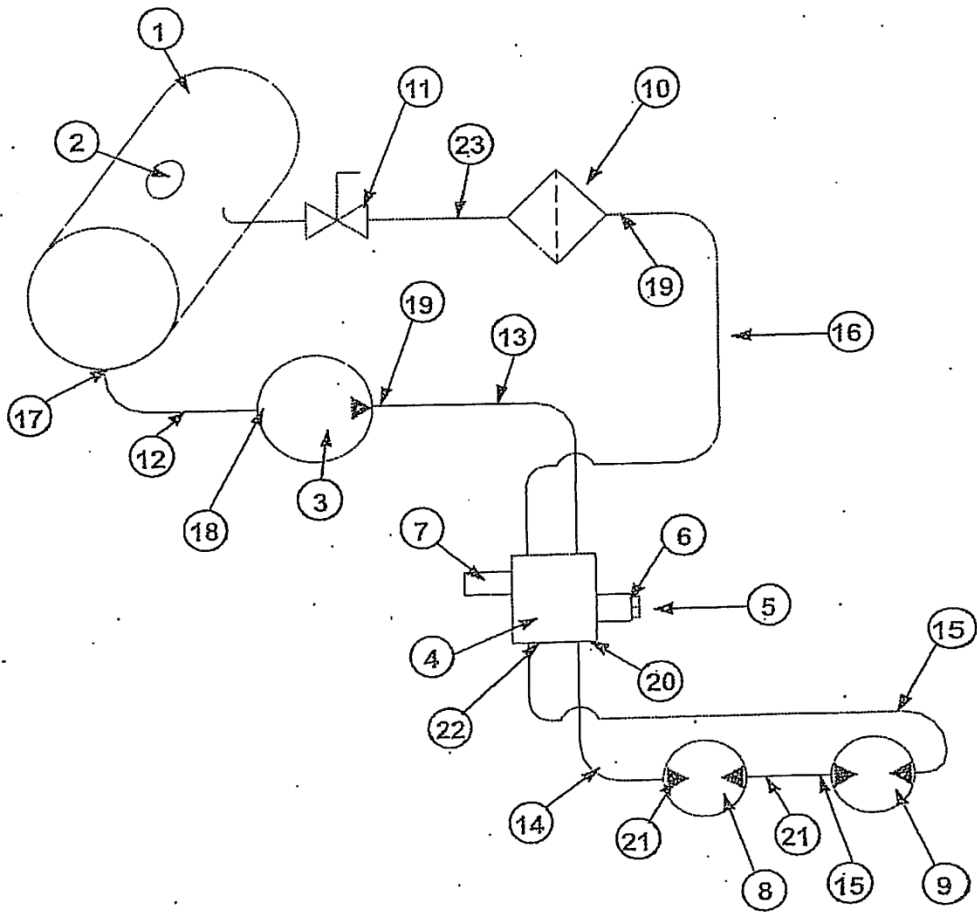
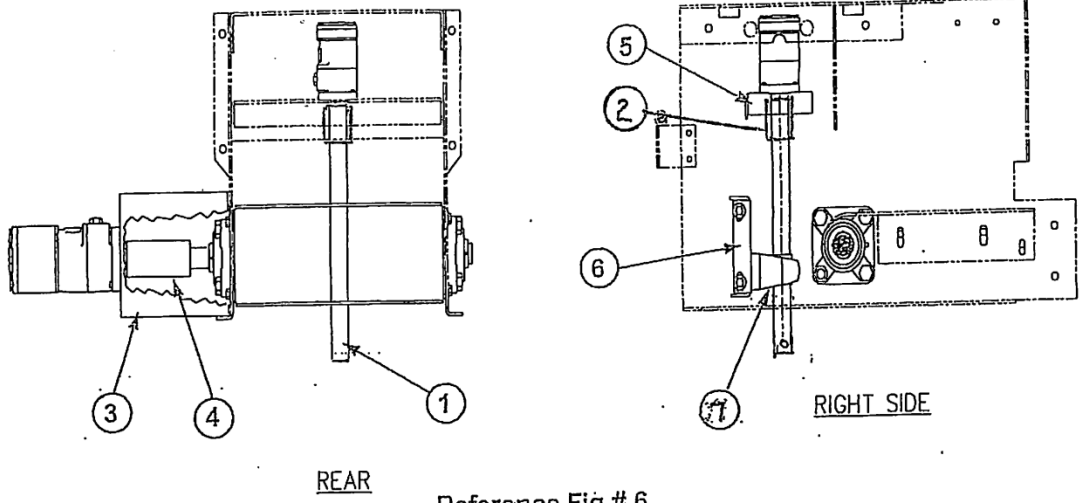

Item No.	Part Number	Part Description
----------	-------------	------------------

Hydraulic Drive Assembly - Figure # 6

1	EGH-C17	Spinner Coupler Shaft - 1" x 8 1/2"
2	EGH-C17-1	Flex Coupler Spinner Motor
3	EGH-EH200	Conveyor Motor Bracket
4	T220208	Conveyor Motor Coupling (4")
5	EGH-C19M	Spinner Motor Mount Bracket
5	EGH-C19MS	SS Spinner Motor Mount Bracket
6	EX19	Pillow Block Mounting Bracket
7	EX36P	Pillow Block Bearing
8	EGH-C25-1	Pump Mounting Bracket
9	EGH-C25-C4	Pump Coupling
10	EGH-C25-C4A	3/4" Bore Coupling Half
11	EGH-C25-C4B	7/16" Coupling Half
12	EGH-C25-C4C	Coupling Inster (Nitrile)

Hydraulic Plumbing - Figure # 7

1	EGH-C81	Hydraulic Reservoir - 5 Gal
2	EGH-C81-4	Filter Breather Assembly w/ Screen
3	EGH-C4	Hydraulic Pump
4	EGH-C83	Relief Block Complete
5	EGH-C83-2	Solenoid Valve
6	EGH-C83-4	Relief Valve
7	EGH-C83-3	12VDC Solenoid Coil
8	EGH-CCM-1	Conveyor Motor
9	EGH-CSM-1	Spinner Motor
10	EGH-C84-1	Filter Head Only
10	EGH-C84-2	Filter Can/Filter Element
11	EGH-C85	Shut-Off Valve
12	EGH-CH96	Suction Hose (Reservoir to Pump)
13	EGH-CH97	15" Hose Assembly (Pump to Relief Block)
14	EGH-CH99	14" Hose Assembly (Relief Block to Conveyor Motor)
15	EGH-CH94	18 1/2" Hose Assembly (Conv. To Spin/Spin to Relief Block)
16	EGH-CH98	13" Hose Assembly (Relieft Block to Filter Head)
17	EGH-C86	Elbow - 90 °Male NPT x JIC -8-8 (Reservoir Suction)
18	EGH-CH96A	Hose Coupling Male Barb x Male NPT -8-6 (Pump Inlet)
19	EGH-C92	Elbow - 90 °Male NPT x JIC -6-6 (Pump Outlet/Filter In)
20	EGH-C93	Elbow - 90 °Male NWO x JIC -6-6 (Relief Block to Conveyor)
21	EGH-C89A	Elbow - 90 °Male NWO x JIC -6-8 (Conv. Motor)
22	EGH-C88	Adapter - Male O-ring x JIC -6-6 (Relief Block to Spin)
23	EGH-C91	Adapter - Male NPT x Male NPT -6-6 (Filter Head to Shut-Off)

E09 - SCREEN ASSEMBLY

#	QTY	DESCRIPTION	PART #
1	1	SCREEN - 8 FT	ESC-8
2	4	J-HOOK	EHD-JHK
3	4	H.D. RATCHET	EHD-RTC
4	4	H.D. NYLON STRAP W/ HOOK (55")	EHD-STR

* LOCATE HOLD DOWNS ADJACENT TO CORNER
GUSSET OR TOP CROSS MEMBERS

E10 - OPTIONAL EQUIPMENT

#	QTY	DESCRIPTION	PART #
5	1	HEADBOARD (CAB SHIELD)	EHBD
6	1	INVERTED VEE (CONVEYOR BRIDGE)	EINV

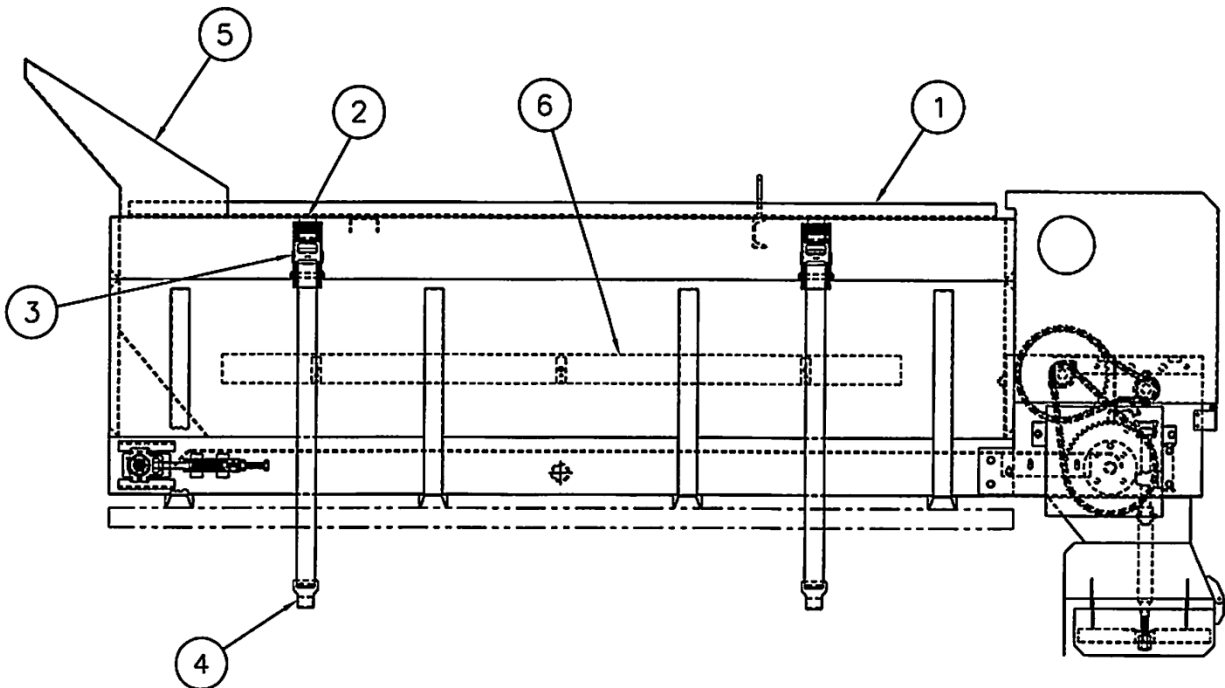

LEFT SIDE FIG-9



#	QTY	DESCRIPTION	PART #
*	1	GEAR BOX CONVERSION KIT	EX-CON
*	1	GEAR BOX CONVERSION KIT - LONG	EX-CONL
1	1	DIRECT DRIVE GEAR BOX	EX36
2	1	GEAR BOX MOUNT BRACKET	EX36B
3	1	PILLOW BLOCK BEARING - 1"	EX36P
4	1	SPINNER BRACKET	EX19
5	2	DRIVESHAFT BEARING - 1"	E38
	4	FLANGETTE (INCL. W/ E38)	E38-1
	2	LOCK COLLAR (INCL. W/ E38)	E38-2
6	1	11 TOOTH SPROCKET - 1"	E26
7	1	WOODRUFF KEY - 5/32 X 5/8	E39-1
8	1	SQUARE KEY - 1/4 X 1	E39-2
9	1	1/2-20 HEX NUT	G052000
10	REF	STD SPINNER SHAFT - 14" (INCL. W/ EX-CON)	EX17S
11	REF	LONG SPINNER SHAFT - 26" (INCL. W/ EX-CONL)	EX17L
12	REF	SHEAR BOLT - 5/16-18 x 2 (W/ LOCKNUT)	EX17SB

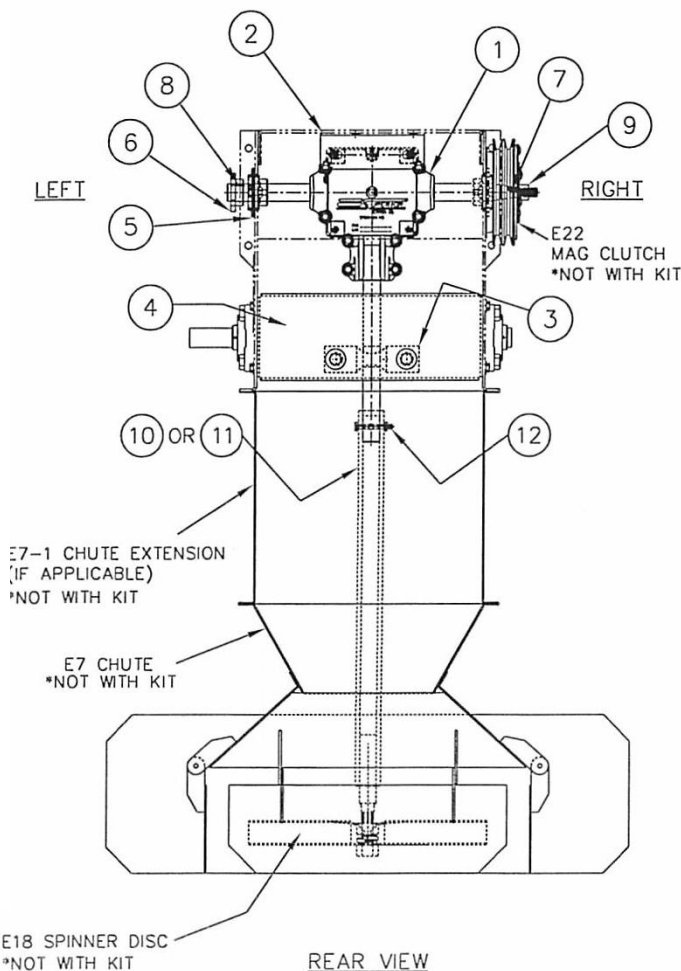

GEAR BOX CONVERSION PROCEDURE

REMOVAL OF DRIVE WHEEL COMPONENTS:

- 1: REMOVE E18 SPINNER DISC AND E7 CHUTE (W/E7-1 EXTENSION IF APP.)
- 2: REMOVE E17-19 SPINNER ASSEMBLY
- 3: REMOVE E23 'V' BELTS FROM E22 MAG CLUTCH (RIGHT SIDE)
- 4: REMOVE 1/2" HEX NUT FROM E39 TAPERED MAIN DRIVE SHAFT (R/S)
- 5: REMOVE MAG CLUTCH (RIGHT SIDE)
- 6: DISCONNECT E31 61 PITCH CHAIN (LEFT SIDE)
- 7: CUT AWAY MAIN DRIVE SHAFT (W/ E36 DRIVE WHEEL)
ON EITHER SIDE OF THE DRIVE WHEEL INSIDE THE SIDE PLATES
- 8: UNBOLT THE TWO FLANGETTES (W/ E38 BEARING AND LOCK COLLARS) FROM THE LEFT AND RIGHT SIDE PLATES
- 9: REMOVE THE TWO LENGTHS OF THE CUT E39 SHAFT FROM THE LEFT AND RIGHT SIDE PLATES
- 10: REMOVE ALL ATTACHING HARDWARE CONNECTED TO THE DRIVE WHEEL INCLUDING THE E48 YOKE GUIDE SHAFT
- 11: THE 'INBOARD' PORTION OF THE REAR MOUNT ASSEMBLY IS OPEN AND READY FOR THE GEAR BOX CONVERSION KIT INSTALLATION

INSTALLATION OF GEAR BOX COMPONENTS:

- 1: FASTEN (LOOSELY) TWO E38 BEARINGS AND FLANGETTES ON THE LEFT AND RIGHT SIDE PLATES
- 2: PLACE LOCK COLLARS ONTO BOTH SIDES OF THE EX36 GEAR BOX
- 3: SLIDE GEAR BOX INTO L/S BEARING THEN ONTO R/S BEARING
- 4: INSERT E39-1 WF KEY ONTO R/S OF OF GEAR BOX TAPERED SHAFT
- 5: PLACE CLUTCH ONTO R/S PLATE (OVER TAPERED END OF THE SHAFT) AND FASTEN W/ 1/2" HEX NUT (LOOSE)
- 6: POSITION CLUTCH SO THAT IT SPINS FREELY ON MAG (NO BINDING)
- 7: TIGHTEN 1/2" NUT
- 8: TIGHTEN BEARING FLANGETTES AND LOCK COLLARS
- 9: RECHECK CLUTCH FOR FREE SPIN. IF CLUTCH BINDS, REPEAT 5 & 6
- 10: REATTACH 'V' BELTS
- 11: INSERT E39-2 SQ KEY ONTO THE LEFT SIDE OF THE GEAR BOX SHAFT
- 12: ATTACH E26 SPROCKET TO SHAFT
- 13: ALIGN 11 TOOTH SPROCKET W/ 48 TOOTH SPROCKET AND TIGHTEN ALLEN SCREW ON SPROCKET
- 14: REATTACH E31 61 PITCH INTERMEDIATE CHAIN
- 15: ATTACH EX36B GEAR BOX MOUNT BRACKET TO MOTOR BED
- 16: BOLT GEAR BOX TO MOUNT BRACKET
- 17: ATTACH EX19 SPINNER BRACKET TO SIDE PLATES (FLANGE TO REAR)
- 18: TIGHTEN BOLTS FOR SPINNER BRACKET AT LOWEST SETTING OF HOLES
- 19: SLIDE EX36P PILLOW BLOCK BEARING ONTO GEAR BOX OUTPUT SHAFT
- 20: BOLT BEARING TO SPINNER BRACKET
- 21: TIGHTEN BEARING ALLEN SCREW
- 22: ATTACH EX17 SPINNER SHAFT TO GEAR BOX SHAFT USING EX36SB
- 23: REATTACH CHUTE (W/EXTENSION, IF APPLICABLE) AND SPINNER DISC

FIG-11



