



[www.storks.com](http://www.storks.com)

## Installation, Operation and Maintenance Manual

For use with Meyer Elite  
utility vehicle, pickup vehicle  
and medium-duty pickup vehicle  
models.





# Registration Data Sheet



## Thank You...

Thank you for buying your Meyer spreader. As a new owner of hard-working, mechanical equipment, we strongly urge you to spend quality time with this owner's manual. It's easy to use and full of time-saving tips that will enhance your ownership experience. It includes suggestions for faster installation, safe operation and more productive spreading.

Thanks again for your business. You can now look forward to many years of reliable performance and keeping your driveway safer and easier to use. If you have any questions about your Meyer spreader, contact us at: [www.meyerproducts.com](http://www.meyerproducts.com) or call 216-486-1313.

Eric S. Larsen, President & CEO, ASH North America

Owner Name \_\_\_\_\_

Address \_\_\_\_\_

City \_\_\_\_\_

State/Province \_\_\_\_\_ Zip/Postal Code \_\_\_\_\_

Purchased From Company Name \_\_\_\_\_

Contact Name \_\_\_\_\_

Address \_\_\_\_\_

City \_\_\_\_\_

State/Province \_\_\_\_\_ Zip/Postal Code \_\_\_\_\_

Phone Number ( \_\_\_\_\_ ) \_\_\_\_\_

E-mail \_\_\_\_\_

Date Purchased \_\_\_\_\_

Vehicle Make \_\_\_\_\_ Vehicle Model \_\_\_\_\_

Vehicle Year \_\_\_\_\_ Spreader Model \_\_\_\_\_

Spreader Serial Number \_\_\_\_\_

# Meyer® One Year Warranty

Meyer Products warrants to the original purchaser only that it will repair, or at the sole option of Meyer Products replace any part of this Meyer Spreader or Spreader accessory which proves to be defective in workmanship or material under normal use for its intended purpose, that being spreading material, for a period of one year from the date of delivery. This warranty is not transferable or assignable. The original purchasers sole and exclusive remedy against Meyer Products and Meyer Products sole obligation for any and all claims, whether for breach of contract, warranty, tort (including negligence) or otherwise shall be limited to providing, through its authorized Distributor/Sub-Distributor network, all labor and/or parts necessary to correct such defects free of charge. Any cost incurred in returning the product to the Distributor/Sub-Distributor is the responsibility of the consumer. The gasoline engine used in the Insert Hopper Spreaders is covered by its own warranty as provided by the engine manufacturer. A copy of this warranty is included with the engine.

## Warranty Service

In order to obtain service under this warranty, the original purchaser must return the claimed defective part to the Distributor/Sub-Distributor from whom the product was purchased or to any authorized Meyer Distributor/Sub-Distributor, transportation and freight charges prepaid. Only Meyer Distributors/Sub-Distributors are authorized to perform the obligations under these warranties. For the address and telephone number of the Distributor/Sub-Distributor nearest you, check the telephone directory or you may write to Meyer Products at the address below.

## General

It is the responsibility of the original purchaser to establish the warranty period by verifying the original delivery date. A bill of sale, cancelled check or some other appropriate payment record may be kept for that purpose. It is recommended, but not required, that the consumer verify by immediately returning the attached Warranty Registration Card. No person is authorized to change this warranty or to create any warranty other than that set forth herein. This warranty gives you specific legal rights and you may also have other rights which vary from state to state.

## Exclusions

This warranty does not cover paint or expendable spreader parts such as pins, spreader fins and other normal wear items. Meyer Products shall not be liable for any special, indirect or consequential damages arising hereunder, or for damages resulting from lack of necessary maintenance, from misuse, abuse, acts of god, alteration of a Meyer Spreader or part, or from use of parts or hydraulic fluid not supplied by Meyer Products. Use of the Meyer Spreader for any purpose other than spreading the recommended materials is one example of an abuse and misuse of the product.

The foregoing warranty is exclusive and in lieu of all warranties, express or implied, including, but not limited to, any implied warranty of merchantability or fitness for a particular purpose.

















# Table of Contents

Thank You.....	2	Electric Controller Information .....	32-33
Registration Data Sheet .....	3	Gas Engine Controller Information .....	34-36
Warranty/Contact Meyer.....	4	Operating Instructions .....	37
Table of Contents.....	5	Maintenance .....	38-42
Introduction.....	6	Troubleshooting .....	43-45
Safety Definitions .....	7-9		
Safety Decal Locations .....	10-11		
Safety Guard .....	12-13		
Spreader Component Identification			
Electric/Hydraulic Spreader.....	14-15		
Gas Engine Spreader.....	16-17		
Vehicle Loading .....	18-19		
Installation / Assembly Instructions .....	20-21		
Rear Cover Instructions.....	22-25		
Spinner Installation.....	26-27		
Electrical & Hydraulic Schematics .....	28-31		

Meyer offers a complete line of spreaders for any application and vehicle size. Go to [www.MeyerProducts.com](http://www.MeyerProducts.com) for more information.



# Safety Definitions & Warnings

1		<b>NEVER</b> stand or ride on the spreader. Failure to comply will result in death or serious injury.
2		Keep hands, feet, and clothing away from power driven parts. Failure to comply will result in death or serious injury.
3		Make sure spreader is completely shut off and all movement has stopped before attempting to clean, service or unclog. Failure to comply will result in death or serious injury.
4		Never enter hopper while spreader is operating or capable of being operated. Failure to comply will result in death or serious injury.
5		<b>NEVER</b> operate or service your spreader without first CAREFULLY reading the Owner's Manual. It is CRITICAL for your safety to ALWAYS obey EVERY warning in the manual and follow EVERY instruction EXPLICITLY. Failure to comply could result in death or serious injury.
6		Never leave operator's position without first completely turning off spreader, disengaging PTO, shutting off hydraulic valve and setting vehicle parking brake. Failure to comply will result in death or serious injury.
7		Never operate spreader without all shields, guards, and safety decals in place. Failure to comply will result in death or serious injury.
8		Spreader should only be operated by personnel trained in the safe use and transportation of this equipment.
9		The spreader should NEVER be used for any other purpose other than conveying granular materials or spreading ice melting or traction products on streets, parking lots, road shoulders and driveways. Failure to comply will result in property damage, death or serious injury.
10		Inspect spreader assembly and mounting components and fasteners for wear and damage before and after each use. Worn or damaged components or fasteners could allow spreader to break free from the transport vehicle. Failure to comply will result in death or serious injury.
11		Transport vehicle must not be operated when overloaded. In all cases, the loaded vehicle weight, including the entire spreader system, all aftermarket accessories, driver, passenger, options, nominal fluid levels, and cargo must not exceed the front/rear Gross Axle Weight Rating (GAWR), and total Gross Vehicle Weight Rating (GVWR). These weights ratings are specified on the safety compliance certification label on the driver's side door opening. Failure to comply will result in death or serious injury.
12		Spreader may tip over or fall. Spreader should be solidly supported when being mounted, dismantled, moved, or stored. Failure to comply will result in death or serious injury.
13		Operator, bystanders and pets should be kept at least 50 feet away from spreader during operation. Failure to comply will result in death or serious injury.
14		<b>SAFETY PRECAUTIONS</b> should be used when hydraulic system is operating or being serviced. Hydraulic fluid under pressure can cause a skin injection injury. If you are injured by hydraulic fluid, get medical attention immediately. Failure to comply will result in death or serious injury.
15		Engine exhaust contains lethal fumes. Breathing these fumes, even in low concentrations, can cause death. Never operate engine in an enclosed area without venting the exhaust to the outside. Failure to comply will result in death or serious injury.

## SAFETY DEFINITIONS



This is the safety alert symbol. It is used to alert you to potential personal injury hazards. Obey all safety messages that follow this symbol to avoid possible injury or death.

### DANGER

**DANGER** Indicates an imminently hazardous situation which, if not avoided, will result in death or serious injury.

### WARNING

**WARNING** Indicates a potentially hazardous situation which, if not avoided, could result in death or serious injury.





### CAUTION

**CAUTION** Indicates a potentially hazardous situation which, if not avoided, may result in minor or moderate injury.

### CAUTION

**CAUTION** used without the safety alert symbol indicates a potentially hazardous situation which, if not avoided, will result in property damage.

# Safety Definitions & Warnings

16		A driver's first responsibility is the safe operation of the vehicle and spreader. The most important thing you can do to prevent a crash is to avoid distractions and pay attention to the road. Wait until it is safe to operate mobile communication equipment such as cell phones, two way radios, etc. Failure to comply will result in injury.
17		Vehicle must conform to all local, state, and national regulations regarding the use of reflective markings and flashing lights. Failure to comply will result in injury.
18		Installation of a Meyer spreader may affect your new vehicle warranty. Before beginning spreader installation verify mounting method is acceptable to your vehicle manufacturer. Failure to comply will result in property damage.
19		Warranty does not apply to a Meyer spreader product which has been negligently or improperly assembled or installed. Failure to comply will result in property damage.
20		<b>CAUTION:</b> To avoid harm to vehicles electrical system always disconnect battery before beginning installation. DO NOT BURN holes or WELD vehicle frame. This may cause frame failure. Failure to comply will result in property damage.



## SAFETY DEFINITIONS



This is the safety alert symbol. It is used to alert you to potential personal injury hazards. Obey all safety messages that follow this symbol to avoid possible injury or death.

### DANGER

**DANGER** Indicates an imminently hazardous situation which, if not avoided, will result in death or serious injury.

### WARNING

**WARNING** Indicates a potentially hazardous situation which, if not avoided, could result in death or serious injury.

### CAUTION

**CAUTION** Indicates a potentially hazardous situation which, if not avoided, may result in minor or moderate injury.

### CAUTION

**CAUTION** used without the safety alert symbol indicates a potentially hazardous situation which, if not avoided, will result in property damage.

# Safety Decal Locations

These safety alert decals are used to alert you of potential personal injury hazards.

Obey all safety messages that follow the symbol to avoid possible injury or death.

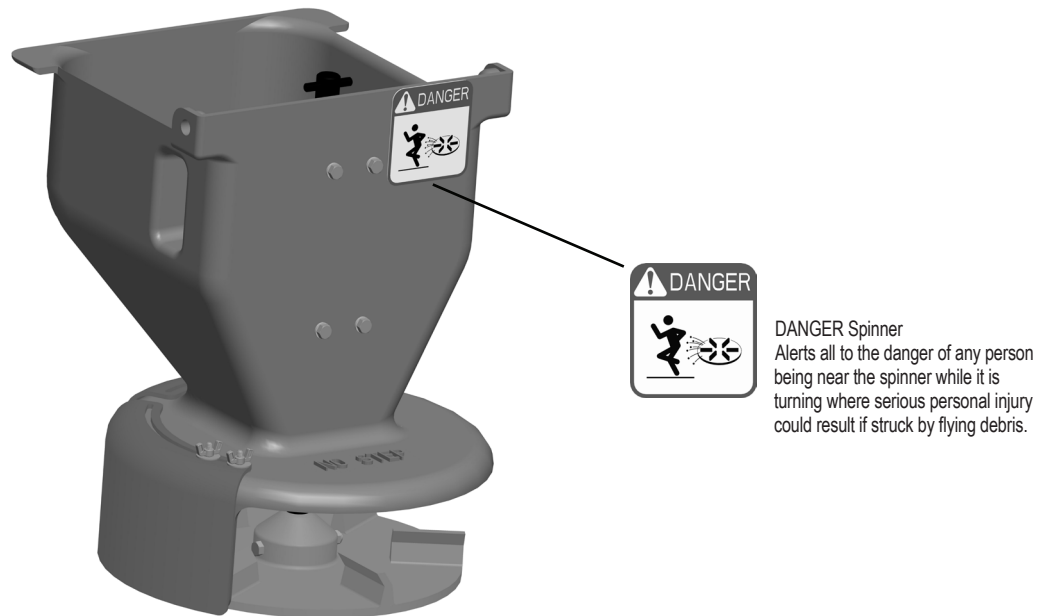

# Safety Decal Locations

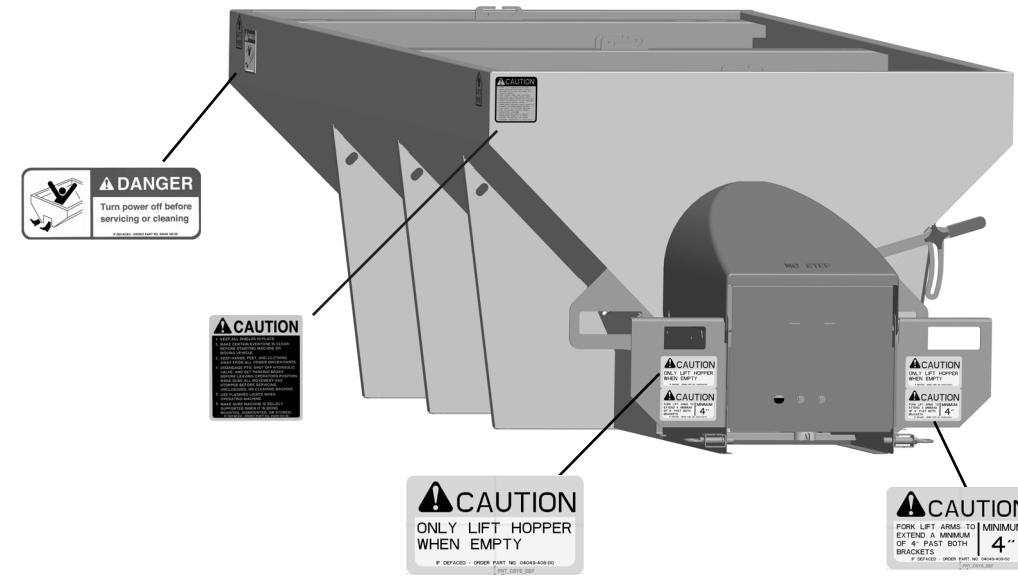

**DANGER Conveyor**  
Alerts all to the danger of serious personal injury or death while servicing or cleaning this equipment without first turning off or disconnecting all power sources.

**CAUTION**  
Cautions all to observe general safety procedures when operating, moving, storing, cleaning or servicing this equipment.

**CAUTION Empty Hopper**  
This decal cautions all to only lift or move equipment when hopper is empty to prevent the risk of serious personal injury or property damage

**CAUTION Fork Length**  
This decal cautions all to make sure fork lift arms extend a minimum of 4"(10.2cm) past both brackets before lifting or moving equipment to prevent the risk of serious personal injury or property damage.

# Safety Guards

To prevent serious personal injury or death all safety guards/covers must be securely fastened in the proper location while equipment is operating or capable of being operated.

# Safety Guard Locations

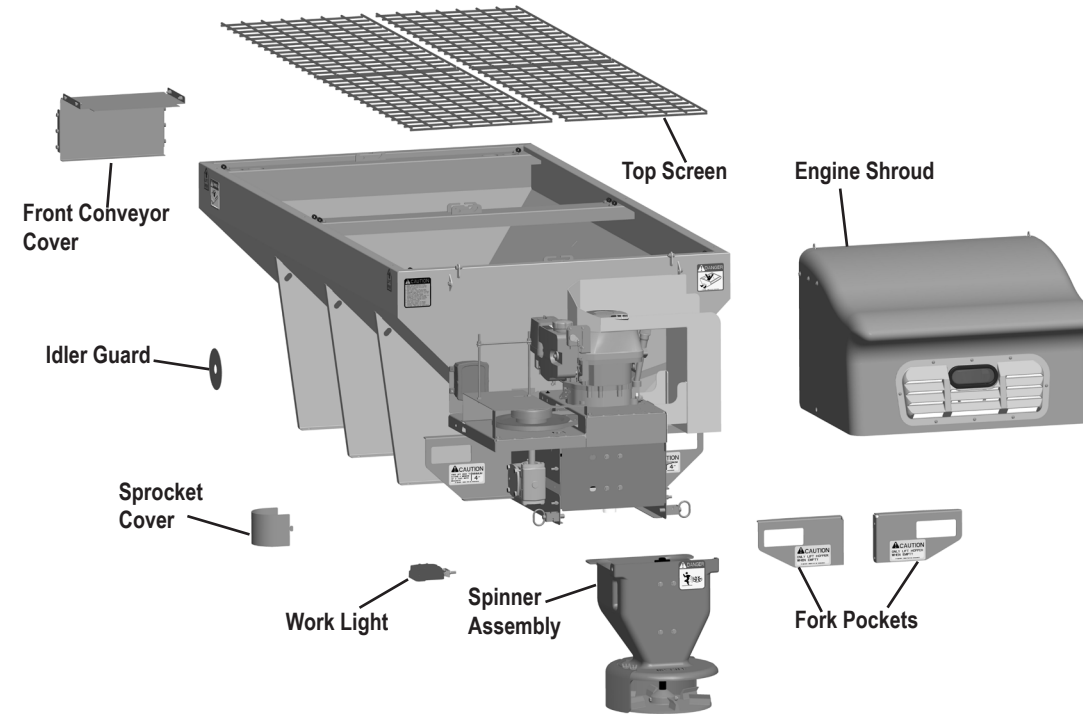

# Component Identification - Electric/Hydraulic

# Component Identification

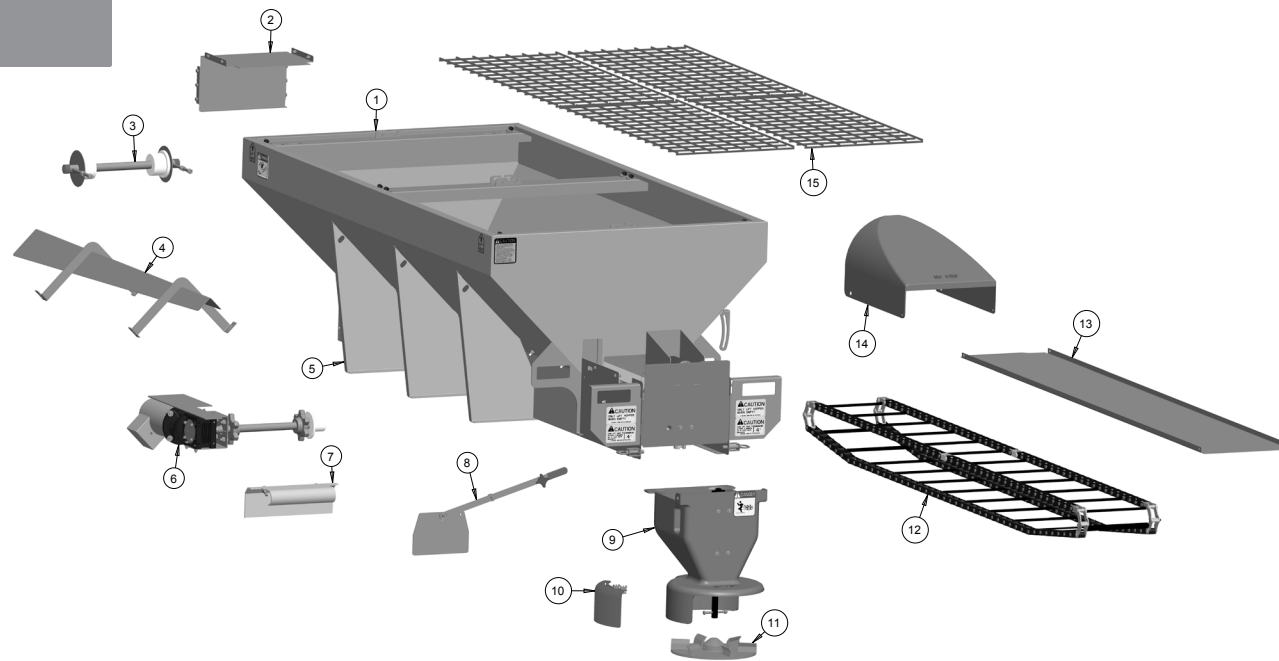

**1. Hopper** - Steel hopper holds spreading material

**2. Front Conveyor Cover** - Encloses the idler assembly

**3. Idler Assembly** - Applies tension to the drag chain

**4. Inverted Vee** - Keeps full weight of material off the drag chain

**5. Body Jacks** - Supports the hopper and allows spreader to be bolted to vehicle

**6. Motor/Gearbox** - Supplies power to turn drag chain

**7. Rear Wiper** - Cleans excess material from the drag chain

**8. Feedgate** - Regulates amount of material discharged from the conveyor

**9. Spinner assembly** - Distributes material onto the road surface

**10. External Baffle** - Adjusts the width of the spread pattern

**11. Spinner Disc** - Rotates at a high RPM to eject material from the spinner assembly

**12. Drag Chain** - Moves material from the hopper to the spinner assembly

**13. Conveyor Floor** - The surface on which material is collected by the drag chain

**14. Motor Cover** - Protects spinner motor from moisture and debris

**15. Top Screen** - Breaks up large clumps of material and prevents foreign objects from entering the hopper



# Component Identification - Gas Engine

www.storks.com

# Component Identification

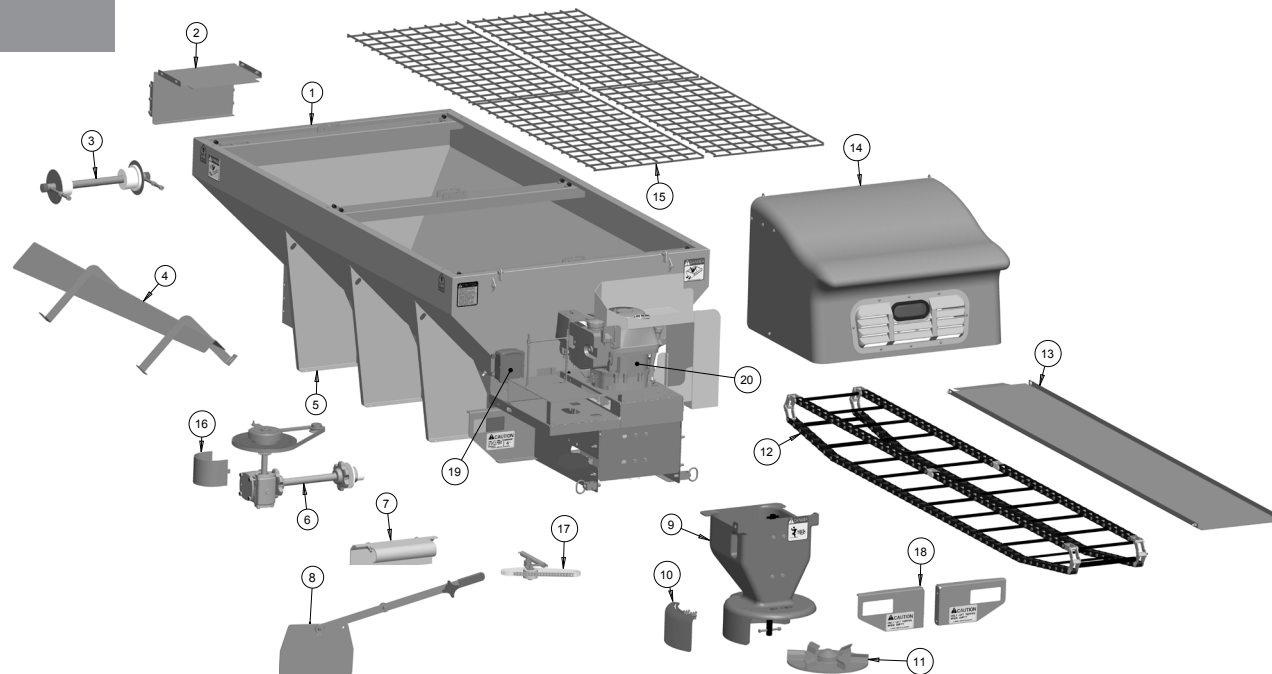

**1. Hopper** - Steel hopper holds spreading material

**2. Front Conveyor Cover** - Encloses the idler assembly

**3. Idler Assembly** - Applies tension to the drag chain

**4. Inverted Vee** - Keeps full weight of material off the drag chain

**5. Body Jacks** - Supports the hopper and allows spreader to be bolted to vehicle

**6. Gearbox** - Supplies power to turn drag chain

**7. Rear Wiper** - Cleans excess material from the drag chain

**8. Feedgate** - Regulates amount of material discharged from the conveyor

**9. Spinner assembly** - Distributes material onto the road surface

**10. External Baffle** - Adjusts the width of the spread pattern

**11. Spinner Disc** - Rotates at a high RPM to eject material from the spinner assembly

**12. Drag Chain** - Moves material from the hopper to the spinner assembly

**13. Conveyor Floor** - The surface on which material is collected by the drag chain

**14. Engine Shroud** - Protects engine from moisture and debris

**15. Top Screen** - Breaks up large clumps of material and prevents foreign objects from entering the hopper

**16. Sprocket Cover** - Protects sprocket from debris

**17. Chain Tensioner** - Keeps constant tension on drive chain

**18. Fork Pockets** - Allow for loading and unloading with a forklift

**19. Wireless Receiver** - Controls engine via wireless controller (not shown)

**20. Engine** - Supplies power to drive the conveyor and spinner

# Vehicle Loading

## Determining Vehicle Payload

It is necessary to calculate the available material payload to prevent overloading the vehicle. Overloading the vehicle can create dangerous stability and braking problems. Always consult and follow vehicle manufacturer's weight ratings and mounting instructions.

1. Mount complete spreader and any optional equipment on vehicle.
2. Attach all additional equipment onto vehicle such as snow plow, hitch, etc that will be used when spreader is mounted on vehicle.
3. Fill fuel tanks.
4. With normal operator(s) inside of vehicle, weigh vehicle to obtain the Gross Vehicle Weight (GVW).

5. Obtain Gross Vehicle Weight Rating (GVWR), Front Gross Axle Weight Rating (FGAWR), and Rear Gross Axle Weight Rating (RGAWR) from the driver's door jam or from the vehicle manufacturer.
6. Subtract the GVW from the GVWR to obtain the available material payload.
7. Divide the payload by the material density to determine the maximum volume of material that can be carried by the vehicle.
9. Load vehicle with the calculated volume of material.
10. Weigh vehicle to verify vehicle does not exceed GVWR, FGAWR, or RGAWR.
11. Repeat procedure for each type of spreading material to be used.

Vehicle Information	
Make	
Model	
Year	
Unit #	
GVWR	lbs.
FGAWR	lbs.
RGAWR	lbs.

Available Payload Calculation			
FGAWR	lbs.	FGAW must not exceed the vehicle FGAWR	
FGAW	lbs.		
RGAWR	lbs.	RGAW must not exceed the vehicle RGAWR	
RGAW	lbs.		
GVWR	lbs.	GVW must not exceed the vehicle GVWR	
GVW	lbs.		
Available Payload	lbs.	Subtract the GVW from the GVWR to obtain the available payload	

# Vehicle Loading

Hopper Volume	
Spreader	yd <sup>3</sup>
Elite Insert Spreader - 3.0	0.30
Spreader	m <sup>3</sup>
Elite Insert Spreader - 3.0	0.23

Hopper Volume	
Spreader	m <sup>3</sup>
Elite Insert Spreader - 4.0	0.4
Elite Insert Spreader - 6.0	1.5
Elite Insert Spreader - 8.0	2.0
Elite Insert Spreader - CS 8.0	2.0
Spreader	m <sup>3</sup>
Elite Insert Spreader - 4.0	0.3
Elite Insert Spreader - 6.0	1.1
Elite Insert Spreader - 8.0	1.5
Elite Insert Spreader - CS 8.0	1.5

Hopper Volume	
Spreader	yd <sup>3</sup>
Elite HC Insert Spreader - 8.0	3.5
Elite HC Insert Spreader - 10.0	4.5
Spreader	m <sup>3</sup>
Elite HC Insert Spreader - 8.0	2.68
Elite HC Insert Spreader - 10.0	3.44

Material	Density	
	lbs. per cubic yard	kg per M3
Coarse Salt - Dry	2,052	932
Coarse Sand - Dry	2,700	1,227
Coarse Sand - Wet	3,240	1,472

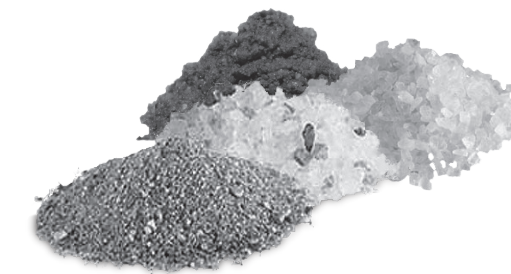

# Installation / Assembly Instructions

*The **Utility Vehicle Model** series spreaders can be mounted and stored as a single unit. The Utility Vehicle Model series spreader will mount on most light / medium duty pickup trucks or utility vehicles.*

*The **Pickup Vehicle Model** series spreaders can be mounted and stored as a single unit. The Pickup Vehicle Model series spreaders will mount on most medium / heavy duty pickup trucks. Pickup Vehicle Model series spreaders can be mounted on 1 ton and larger trucks but may require optional extended spinner.*

*The **Medium-Duty Pickup Model** series spreaders can be mounted and stored as a single unit. Medium-Duty Pickup Model series spreaders can be mounted on most 15,000 to 20,000 GVW and larger trucks.*

# Installation / Assembly Instructions



## Vehicle Preparation

Overloading vehicle can create dangerous stability and braking problems. Always consult and follow vehicle manufacturers weight ratings and mounting instructions.

1. Turn off vehicle engine, set parking brake, and remove keys.
2. Remove tailgate from vehicle.
3. Remove trailer hitch if equipped.

## Spreader Preparation

1. Remove all loose items from inside of hopper such as the spinner assembly, controller, etc.
2. Make sure hopper is completely empty before attempting to lift or move spreader.

## Lifting Spreader

All chains, hooks, and straps must be of an adequate weight rating to support entire spreader including any additional or optional equipment that may be installed. Never attempt to lift or move a spreader with material in the hopper.

## Spreader Installation

Your *ELITE* series spreader should be mounted directly on the vehicle bed, spreader is not designed to be supported by body jacks alone or for chassis mount applications. Shipping skid is intended to be removed before mounting spreader. Verify mounting method is acceptable to the vehicle manufacturer before attempting to mount spreader.

1. Place spreader directly onto bed of vehicle with discharge at the rear of the vehicle.
2. Spreader is designed sit directly on vehicle bed. Do not support spreader by body jacks alone. Spreader is not designed to be chassis mounted.
3. Attach spinner assembly to spreader. Make sure spreader cannot tip when spinner assembly is installed (see spinner assembly installation instructions).
4. Reposition spreader on vehicle bed, just short of the spinner assembly making contact with the rear most part of the bed, bumper, pintle hook, etc.
5. Bolt spreader to the vehicle using a minimum of four 1/2" grade 5 bolts and corresponding washers and lock nuts installed through the mounting hole located in each body jack.
6. Install one ratchet strap from each corner of vehicle bed to appropriate spreader tie down location. Straps should be installed at opposing angles to prevent spreader from sliding in vehicle bed.

# Rear Cover Instructions

# Rear Cover Instructions



## Gas Engine Models

The rear cover of our engine driven models is simple to operate and lightweight.

The cover hinges at the top, latches at the bottom on both sides, and will stay open without having to set a prop rod.

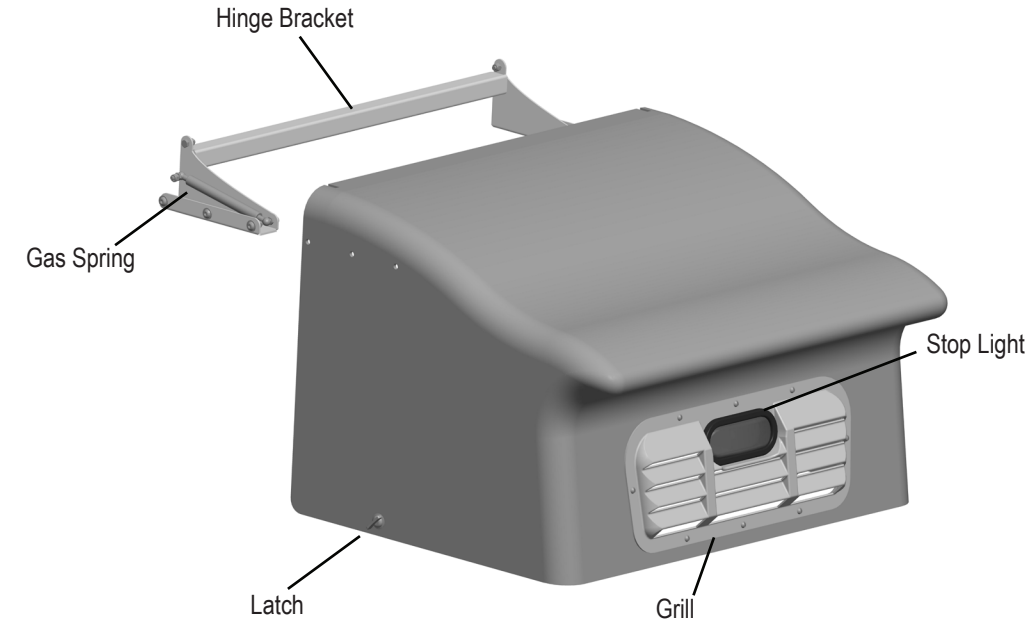
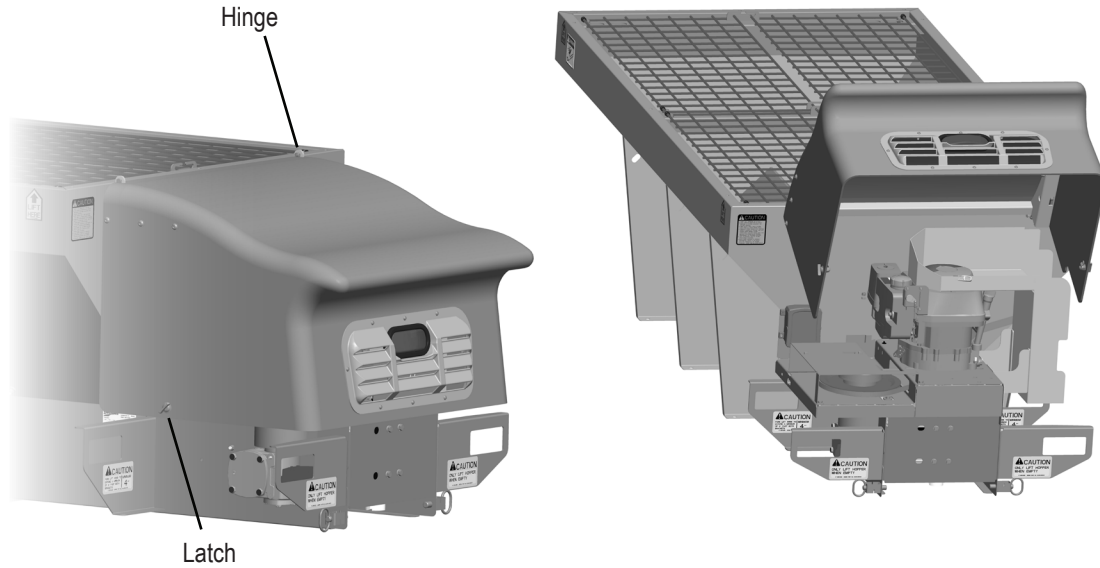

### To open/close the cover:

Disengage the latches. These are located at the bottom, on both sides of, the cover.

Lift from the rear and open the cover to your desired working height. The gas springs will keep the cover open.

When closing, simply push the cover back down and switch both latches to the locked position.

# Rear Cover Instructions

# Rear Cover Instructions



## Electric & Hydraulic Models

Both our electric and hydraulic driven models utilize the same rear cover.

The cover hinges at the rear, latches at the front on both sides, and can be opened past 90 degrees to provide easy access to the components underneath.

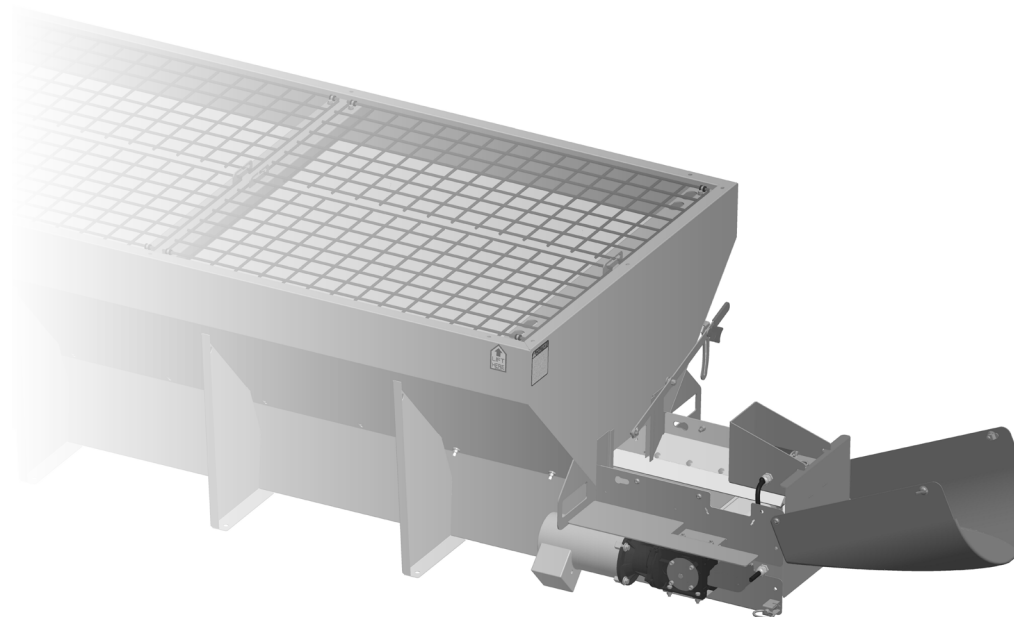
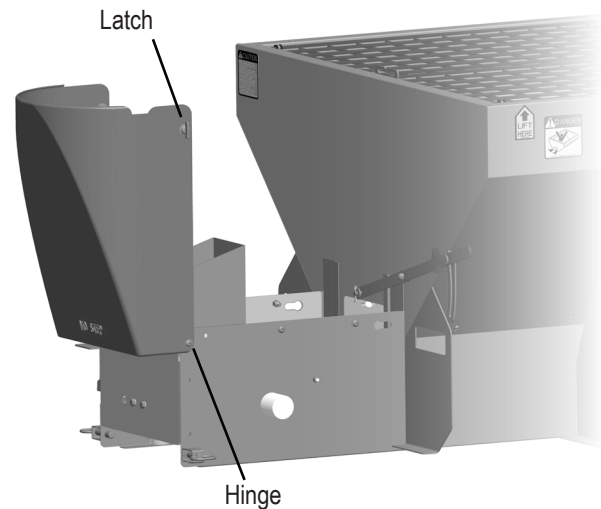
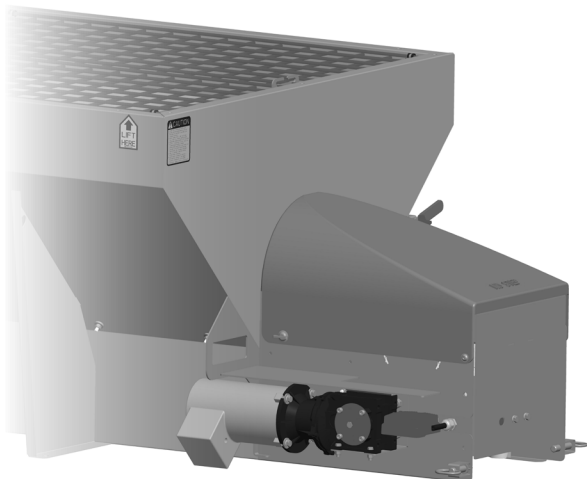

### To open/close the cover:

Disengage the latches. These are located at the front, on both sides, of the cover.

Lift from the front and open the cover to your desired working angle. You can loosen or tighten the hinge bolts to adjust their tension.

When closing, simply push the cover back down and switch both latches to the locked position.

# Spinner Installation

Spinner assemblies are interchangeable between all *ELITE* models. They are available in lengths of 14", 20", 24", and 30".

### Adjusting the External Baffles:

Loosen the wing nuts that attach the baffle to the spinner.

Slide the baffles to desired location.

Then tighten the wing nuts to hold them in place

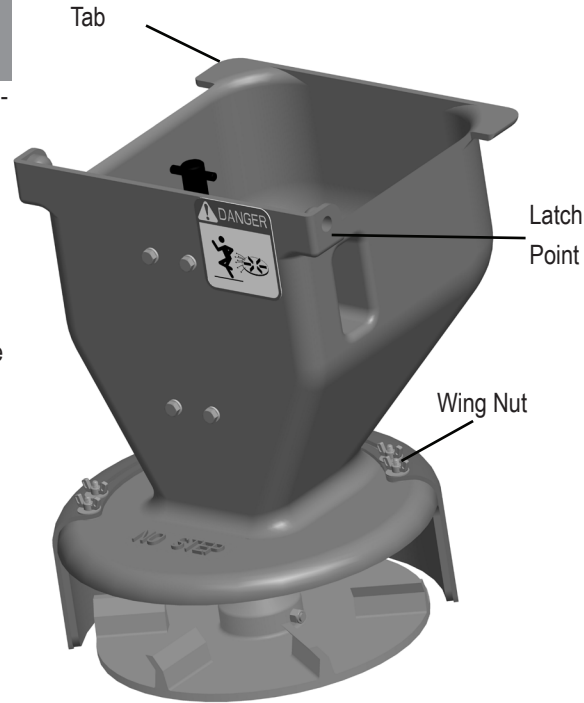

# Spinner Installation



### Installation of the Spinner Assembly:

Place the tabs of your spinner assembly onto the bottom flange of the spreader's long sill beams.

Slide the assembly forward until the latch points in the spinner line up with the spring latch pins on the spreader.

Engage the latches, locking the spinner assembly in the vertical position.



# Hydraulic Schematics

## Single flow controller plumbing

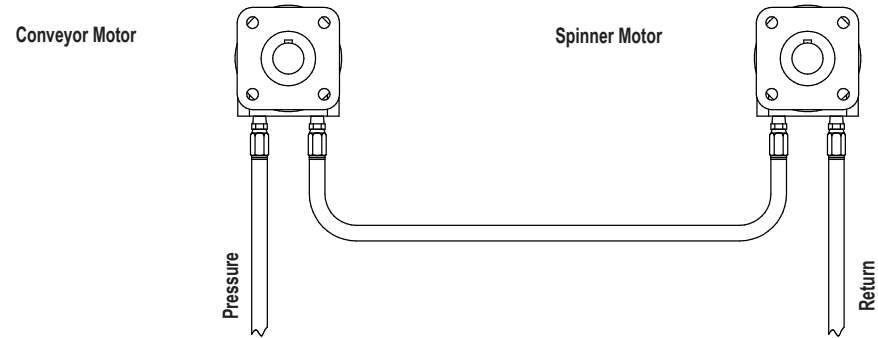

## Dual flow controller plumbing

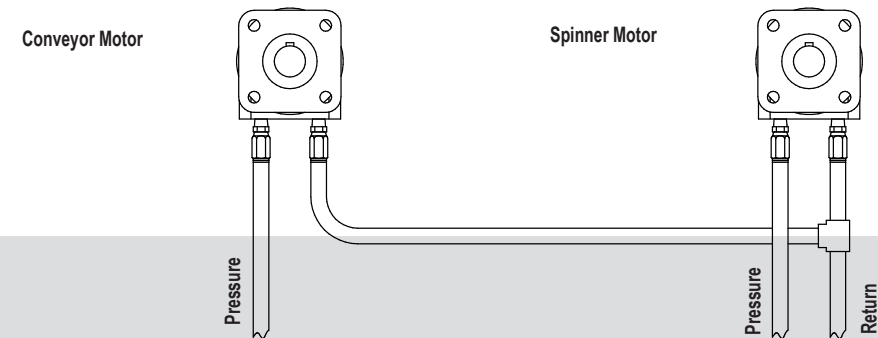

Plumbing schematic for hydraulic spreaders.

Hydraulic System Requirements	
Conveyor Oil Flow	0-15 GPM
Spinner Oil Flow	0-7 GPM
Relief Valve Setting	1500 PSI
Hydraulic Oil	MS10W hydraulic oil with wear, oxidation and foam inhibitors
Oil Filter	10 micron element return line filter

# Wiring Schematics

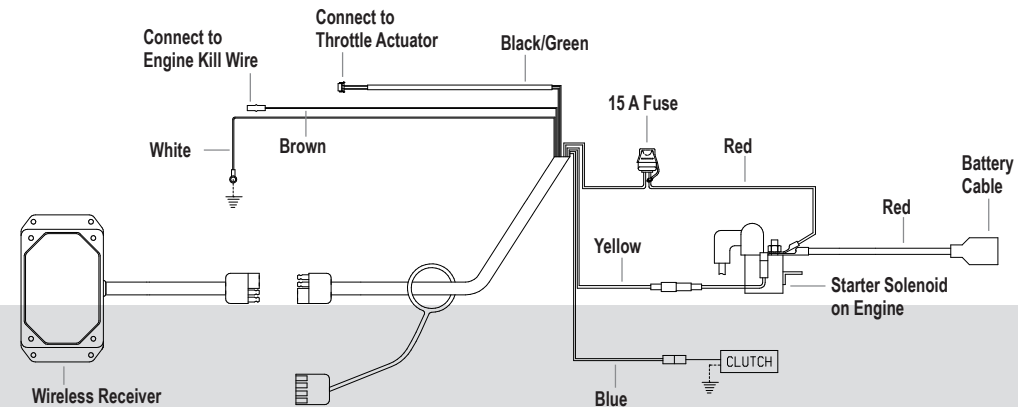
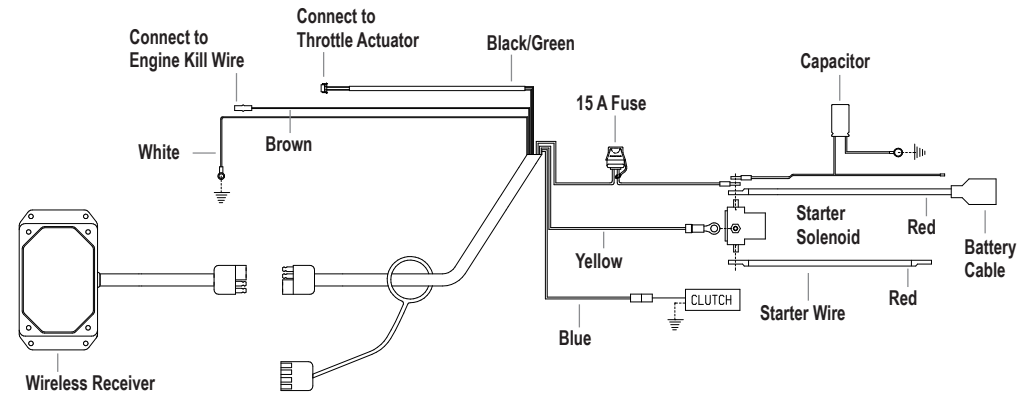

Wiring schematic for spreaders with Briggs & Stratton engine and wireless controller.

Wiring schematic for spreaders with Honda engine and wireless controller.

# Wiring Schematics

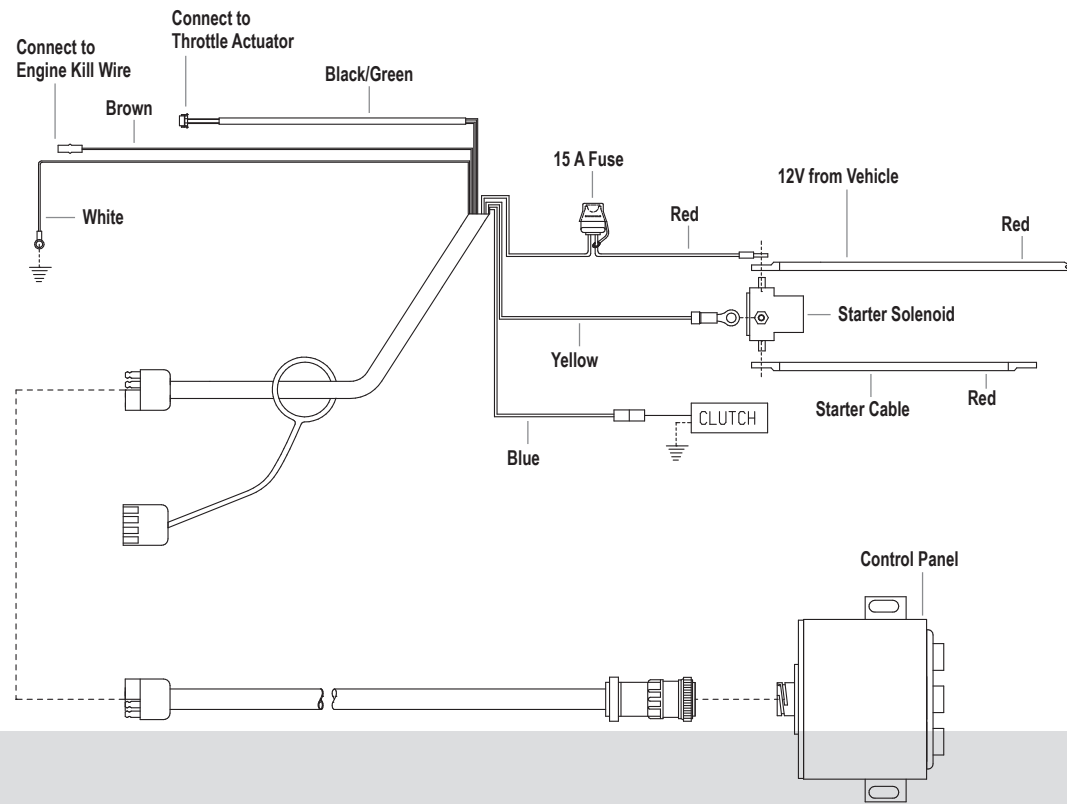

Wiring schematic for spreaders with Briggs & Stratton engine and wired controller.

# Wiring Schematics

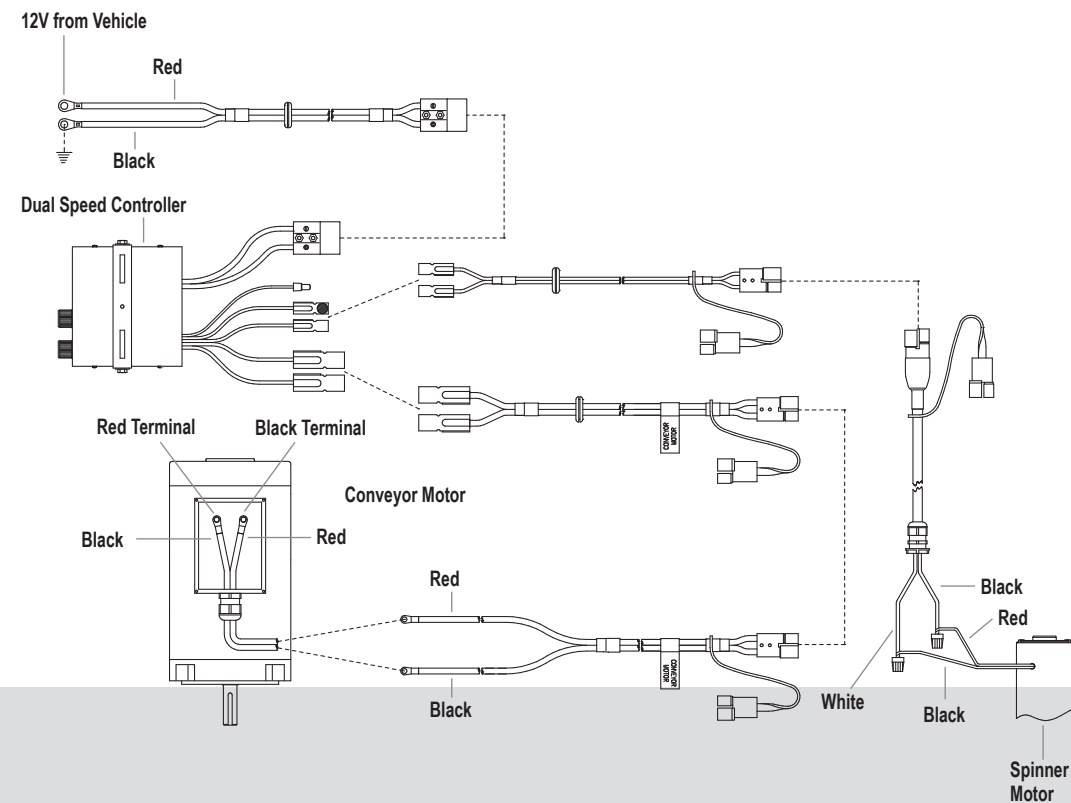

Wiring schematic for electric spreaders with dual variable speed controllers.





# Electric Controller LED Key

www.storks.com

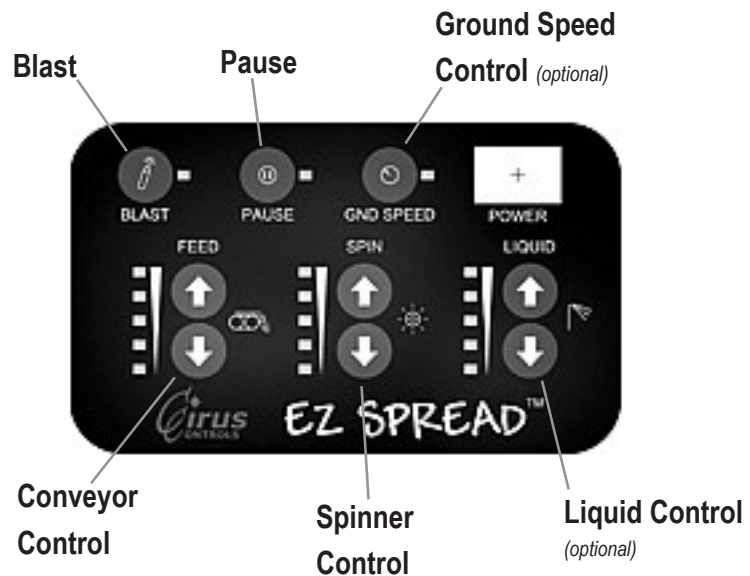

Pause LED On, Spreading stopped



Blast LED On, Blast spreading 0-10 Seconds



Pause LED On (spreading paused)  
Feed LED=2, Spin=4, Liq=6



Pause LED On (spreading paused)  
Feed LED=10, Spin=4, Liq=0



GND LED On constant, spread normal  
Ground speed oriented.



If feed, spin, or aux LED's are flashing, an open or shorted electric circuit is detected and output for that channel is turned off.

*The Cirus EZ Spread Controller comes with a set of instructions for installation and configuration. It is important to follow these steps to ensure optimal performance of your Dual Motor Electric Spreader.*

# Wireless Gasoline Engine Control System

www.storks.com

# Wireless Gasoline Engine Control System



The wireless gasoline engine controller is intended to control the start/stop, throttle increase/decrease, and electric clutch on/off functions. The control system consists of a transmitter and a receiver. The receiver is mounted on the spreader near the gasoline engine. The transmitter is intended to remain in the vehicle cab or with the operator.

## Synchronizing Transmitter and Receiver

Each transmitter and receiver pair are synchronized at the factory. If a new transmitter is needed use the following procedure to synchronize the transmitter and receiver:

1. Make sure both the transmitter and receiver are powered off.
2. Press and hold the POWER button on the transmitter for at least 10 seconds. Both the red and green LED lights will begin to blink.
3. Apply power to the receiver. Wait for a few seconds until only the green LED begins to blink. The transmitter and receiver are now synchronized.

## Sleep Time Adjustment

The sleep mode will automatically shut off the transmitter, disengage the electric clutch, and stop the gasoline engine. The transmitter is factory set to go into sleep mode after 15 minutes of inactivity. Use the following procedure to change the sleep time or disable the sleep mode:

1. With the transmitter powered off, press and hold the POWER, throttle DECREASE, throttle INCREASE, and CONVEYOR buttons.

2. Release the buttons. At this point both the red and green LED lights will blink once per second.
3. On the transmitter press one of the following buttons for the desired sleep time:
  - a. ENGINE STOP = 15 minutes (default setting)
  - b. ENGINE START = 30 minutes
  - c. THROTTLE INCREASE = 1 hour
  - d. THROTTLE DECREASE = 2 hours
  - e. CONVEYOR = Disable sleep mode
4. Sleep time programming is now complete.



Transmitter

### LED LIGHTS

### Transmitter LED Light Codes

Red LED blinks once per second = Low Battery

Green LED blinks once per second = Transmitter on but no communication with the receiver

Green LED blinks twice per second = Transmitter is on and communicating with the receiver

Green LED solid = Clutch is engaged

Note: the green LED located inside the receiver under the cover will blink rapidly when receiving a signal from the transmitter, otherwise it will be off.

## OPERATION

1. Press and hold the POWER button for at least two seconds to turn on the transmitter. The green LED will begin to blink.
2. Set engine throttle to choke by pressing and holding the throttle INCREASE button for at least three seconds.
3. Press and hold the engine START button until the engine starts. Note: continuing to hold the engine start button after the engine starts will result in damage to the engine.
4. Once engine starts, press the throttle DECREASE button to remove throttle from the choke position.
5. Press the throttle INCREASE or throttle DECREASE button until the desired engine RPM is achieved.
6. Engage the electric clutch by pressing the CONVEYOR button once. Pressing the CONVEYOR button a second time will disengage the clutch. Note: the green LED will turn solid whenever the clutch is engaged.
7. Engine can be stopped by pressing the engine STOP or POWER buttons. Note: pressing the engine STOP or POWER buttons will automatically disengage the electric clutch.

## SPECIFICATIONS

- 12 Volt
- Frequency 902-928 MHz FHSS 10mW
- Transmitter battery: Requires standard micro USB wall or car charger

## BUTTON FUNCTIONS

1. Power ON/OFF
2. Engine Start
3. Engine Stop
4. Throttle Decrease
5. Throttle Increase
6. Conveyor ON/OFF

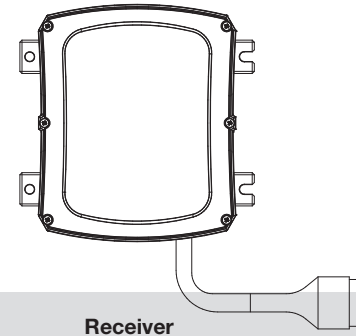

Receiver

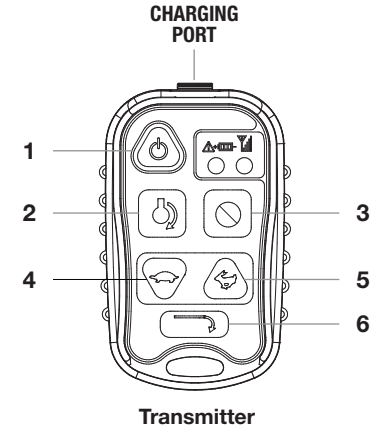

Transmitter

\*High traffic areas such as airports may experience signal interruption due to frequency limitations

# Gasoline Engine Spreader Controller

The gasoline engine spreader controller is intended to control the following functions of the spreader: engine start/stop, engine choke, throttle increase/decrease, and clutch on/off. Control system is made up of the control panel, and harness. Controller is intended to be permanently mounted inside the cab of the vehicle.

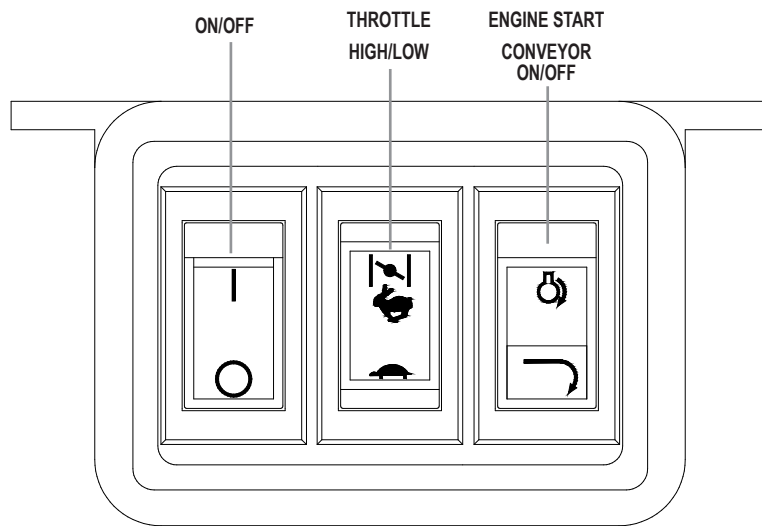

## OPERATION

Controller is not functional until the ON /OFF switch is switched to the "ON" position. Moving the ON/OFF switch to the "OFF" position will stop the engine and shut off power to the entire controller.

1. Move the ON/OFF switch up to the "ON" position.
2. Set engine throttle to choke by pressing and holding the THROTTLE BUTTON up for two seconds.
3. Press and hold the START/CONVEYOR button in the up position until the engine starts. Note: continuing to hold the START button after the engine starts will result in damage to the engine.
4. Once engine starts press the THROTTLE button down to remove the throttle from choke.
5. Press the THROTTLE button up or down until desired engine RPM is achieved.
6. Engage the electric clutch by pressing the START/CONVEYOR button down.
7. Disengage the electric clutch by moving the START/CONVEYOR switch to the middle position.
8. Engine can be shut off by moving the ON/OFF button down to the "OFF" Position.

# Operating Instructions

## Filling Hopper

The hopper should only be filled with clean, dry, free flowing salt, sand or salt/sand mix. Commercial bagged ice melt materials may be used. Spreader is not designed to spread ag lime, gravel, rock, cinders, or any other aggregate materials. Only fill the hopper with the top screen installed to prevent foreign objects or frozen clumps of material from entering the hopper and damaging the conveyor system. Do not leave unused material inside of hopper when not in use. Do not let material freeze inside of hopper.

**Gearbox:** Never apply torque to output shaft of gearbox. Gearbox is designed to only accept torque from the input shaft.

**Engaging Conveyor:** To prevent premature wear of the electric clutch, roller chain and v-belt, engine throttle speed should be lowered to idle before engaging electric clutch.

**Electric Clutch:** To achieve maximum torque, new electric clutches should be burnished prior to the first use. Refer to the maintenance section of this manual for clutch burnishing procedure.

**Transporting Spreader:** It is recommended to turn off the fuel to the engine when transporting spreader without the engine running.

## Regulating amount of material being spread

The amount of material being spread depends upon the conveyor speed and feed gate setting. A slower conveyor speed and lowering the feed gate will decrease the amount of material being spread. A faster conveyor speed and raising the feed gate will increase the amount of material being spread.

## To adjust conveyor speed:

1. Gasoline Engine driven spreader: Increase conveyor speed by increasing engine speed, decrease conveyor speed by decreasing engine speed.
2. Electric Motor driven spreader: Increase conveyor speed by increasing electric motor speed, decrease conveyor speed by decreasing engine speed.
3. Hydraulic driven spreader: Increase conveyor speed by increasing oil flow to hydraulic motor, decrease conveyor speed by decreasing oil flow to the hydraulic motor.

## Adjusting Feed Gate:

1. Loosen adjusting knob.
2. Raise or lower handle until feedgate is at desired height.
3. Firmly tighten adjusting knob.

## Regulating the spread pattern

The spread pattern is the width and direction of material spread. The width of the spread pattern can be regulated by increasing or decreasing the spinner disc speed. The direction of the spread pattern can be regulated by adjusting the external baffles on the spinner assembly.



## Noise & Vibration Reduction

To reduce the amount of noise and vibration produced by the spreader:

1. Keep all mechanical fasteners and guards tight and in their proper location.
2. Periodically clean built-up material from spinner disc.
3. Keep drag chain and roller chains properly adjusted and lubricated.
4. Keep all bearings properly lubricated.
5. Decrease gasoline engine RPM before engaging clutch.
6. Use optional hopper vibrator only as needed.
7. Only spread clean material free of debris such as rocks, wood, asphalt, etc.
8. Maintain engine exhaust system per engine manufacturer's recommendations.

# Maintenance

## Pre-Season Maintenance

Scheduled vehicle maintenance should be performed as recommended by the manufacturer.

### Vehicle Maintenance

Don't forget that in addition to keeping equipment in order:

1. Keep windshield wipers, heaters and lights working.
2. Use emergency flashing lights for increased visibility and safety.
3. Equip vehicle with tire chains when necessary.
4. Provide operators with protective clothing and gloves for handling ice melting chemicals.

### Vehicle Electrical System

For maximum efficiency, the vehicle supporting the spreader must be properly serviced. The system should consist of at least a 70 amp/hr battery and a 60 amp alternator. Be sure to check regularly:

1. Battery terminals to assure they're tight and free of corrosion.
2. Electrical connections, to assure they're tight and corrosion free.
3. Battery must be in top operating condition.
4. Alternator and regulator, to assure maximum electrical output.

### Vehicle Hydraulic System

To prevent any issues with the vehicle hydraulic system, be sure to perform the following prior to the winter season:

1. Flush and refill hydraulic reservoir. Replace hydraulic oil filter.
2. Inspect hydraulic pump, motors, hoses, and couplers for damage or leaks.
3. Refer to hydraulic pump manufacturers maintenance recommendations.

### Spreader

Prior to the start of the winter season the pre-season maintenance should be performed to ensure the spreader operates reliably. Follow the maintenance schedule for service recommendations. Don't forget to also do the following:

1. Verify spreader is securely attached to vehicle.
2. Inspect Spreader for loose, missing, or damaged parts, guards, or hardware.
3. Repaint any rusty parts.
4. Ensure moving parts are free and not corroded.
5. Test run spreader before filling with material.

# Maintenance

**Inspection:** Before and after each use, spreader should be inspected for loose, missing, or damaged mounting hardware, parts, or safety guards. Spreader should also be inspected to ensure it is securely attached to vehicle.

**Cleaning:** Empty all material from spreader after each snow or ice event. Wash entire spreader with soap and warm water paying special attention to the conveyor drag chain. Do not clean spreader with any corrosive chemicals or products that contain chlorides or ammonium. Any commercially available salt neutralizer may be applied.

**Adjusting Drag Chain Tension:** Loosen rear jam nut on take-up bolt and tighten take-up bolt until drag chain is properly tensioned. Drag chain is properly tensioned when the distance between the centerline of the front idler and point where chain contacts flange of longitudinal is between 8 – 20" (20.3 – 50.8cm). Both sides of drag chain must be adjusted evenly.

**Adjusting V-belt/ Roller Chain Tension:** Loosen the gasoline engine or electric motor mounting bolts and slide motor away from gearbox (towards passenger side of vehicle) until proper tension is achieved. Tighten motor mounting bolts to hold motor in position. V-belt or roller chain should have between 1/4" – 5/16" (.6 cm – .8 cm) deflection midway between the sprockets.

**Adjusting Spinner Roller Chain:** Loosen four spinner shaft or spinner drive shaft (Polyhawk models only) mounting bolts and slide shaft away from gearbox (towards passenger side of vehicle) until proper tension is achieved and shaft is straight up and down, then tighten shaft mounting bolts to hold shaft in position. Roller chain should have between 1/4" – 5/16" deflection midway between sprockets. To prevent roller chain failure, both sprockets must be realigned. For Polyhawk models spinner shaft may need to be aligned with the spinner drive shaft after adjusting roller chain tension.

**Gearbox Oil Level:** Check the gearbox oil level every 10 hours of operation or monthly. Gearbox should be filled until oil reaches oil level plug. Oil should be flushed prior to start of season and replaced with an EP 85 W 140 gear type lubricant.

## Gearbox Maintenance

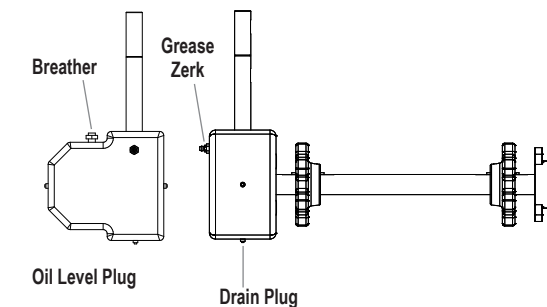

**Electrical System:** Electrical system should be inspected for loose connections and corrosion every 10 hours of operation or weekly. Dielectric grease should be applied to all electrical connections.



## Drag Chain Tension Adjustment

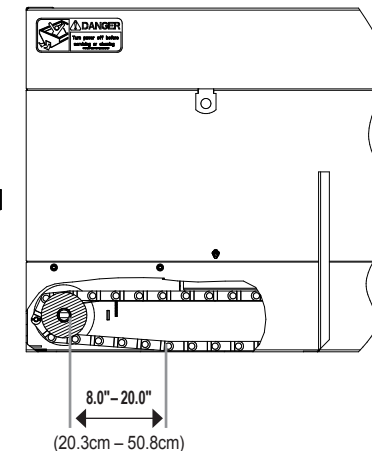

# Maintenance

www.storks.com

# Maintenance



For more information about your Briggs and Stratton motor, or to locate your nearest certified service center, simply scan the QR code on the serial tag of the motor with your mobile device.

To get a QR Code Reader, visit <http://percentmobile.com/getqr>



For more information about your Honda motor, or to locate your nearest certified service center, please call 1-800-626-7326.



# Maintenance

# Troubleshooting Guide



## Maintenance Service Schedule

MAINTENANCE TASK TO BE COMPLETED	Pre-Season	Daily	10 Hours or Weekly	40 Hours or Monthly	Post-Season
Inspect spreader for loose, missing, or damaged parts or hardware	X	X			X
Verify spreader is securely attached to vehicle	X	X			
Inspect electrical connections and apply dielectric grease to connections	X		X		X
Adjust drag chain tension	X			X	
Lubricate drag chain	X		X		X
Adjust roller chain tension	X			X	
Lubricate roller chain	X		X		X
Grease idler and drive shaft bearings	X		X		X
Oil or paint rusty surfaces	X				X
Check Hydraulic Fluid Level	X	X			
Replace hydraulic filter	X			X	
Flush and refill hydraulic reservoir	X				

### Post Season Maintenance

At the end of the winter season, perform the post-season maintenance as listed in the maintenance service schedule to prevent costly repairs at the start of the next season. Also don't forget to:

1. Empty and thoroughly wash entire spreader with warm soap and water.
2. Spreader may be treated with any commercial salt neutralizer.
3. Lubricate drag chain, roller chains, and bearings.
4. Oil or paint any rusty parts or surfaces.

## General Troubleshooting

Condition	Possible Cause	Correction
Conveyor will not operate	Hydraulic system not operating properly	See hydraulic troubleshooting
	Conveyor jammed by a foreign object, or frozen material	Inspect conveyor for obstruction and remove
	Damaged or worn motor	Inspect and repair motor
	Loose or damaged roller chain	Adjust or replace roller chain
	Loose or damaged drag chain	Adjust or replace drag chain
	Worn conveyor drive sprockets	Replace drive sprockets
Conveyor operates erratically	Shaft keys missing from sprockets or motor	Inspect for missing keys and replace
	Hydraulic system not operating properly	Refer to hydraulic system troubleshooting chart
	Loose or damaged roller chain / sprockets	Adjust or replace roller chain / sprockets
	Loose or damaged drag chain	Adjust or replace drag
	Worn conveyor drive sprockets	Replace drive sprockets
	Shaft keys missing from sprockets or motor	Inspect for missing keys and replace

# Troubleshooting Guide

# Troubleshooting Guide



## General Troubleshooting

Condition	Possible Cause	Correction
Noisy operation	Loose or damaged drag chain	Adjust or replace drag chain
	Drag chain needs lubrication	Lubricate drag chain
	Foreign object in conveyor	Remove object
	Faulty bearing	Replace bearing
	Drag chain contacting conveyor frame	Ensure drag chain is centered in conveyor
Material not exiting discharge	Conveyor discharge clogged	Clear material from discharge
	Material bridging inside conveyor	Use free flowing material
	Feed gate closed	Open feed gate
Material leaking from conveyor	Drag chain not properly adjusted	Adjust drag chain tension
	Material too fine	Use coarser material

## Hydraulic Troubleshooting

Condition	Possible Cause	Correction
Pump cavitation recognized by excessive noise	Air entering system through suction line	Check line from reservoir for possible leaks
	Suction line kinked, twisted, or too long	Install suction as short and straight as possible
	Inadequate suction line size	Increase suction line size
	Oil too heavy	Drain and replace with lower viscosity non-detergent oil
	Excessive pump speed	Decrease PTO speed accordingly
Slow operation of conveyor and or spinner motor	Worn or defective pump	Repair or replace pump
	Worn or defective motor	Repair or replace motor
	Pump cavitation	Refer to pump section
	Insufficient pump speed	Increase PTO RPM accordingly
Erratic operation of conveyor and or spinner motor	Low oil	Fill reservoir to 3/4 full
	Worn or defective motor	Repair or replace motor
	Dirty, worn or defective control valve	Clean, repair, or replace flow control
	Plugged filter	Replace filter element
	Relief valve setting too low	Adjust relief valve to 1500 PSI
	Pump cavitation	Refer to pump section
	Reservoir air vent blocked	Clean or replace vent
	Conveyor and or spinner motor will not operate	Quick disconnects are dirty, damaged or improperly connected
Hose connections wrong		Reconnect hoses
Foreign material in valve compensator		Remove compensator and clean
On/off lever on flow control in the off position		Move lever to on position
Flow control set too low		Adjust control to a higher setting

Notes

---

---

---

---

---

---

---

---

---

---

---

---

---

---

---

---

---

---

---

---

---

---

---

---



---

---

Notes

---

---

---

---

---

---

---

---

---

---

---

---

---

---

---

---

---

---

---

---

---

---

---

---



---

---





Meyer Products, LLC  
18513 Euclid Avenue  
Cleveland, Ohio 44112

216-486-1313  
[www.meyerproducts.com](http://www.meyerproducts.com)

Instruction Manual  
Part Number:  
67207