

RTEL SERIES ELECTRIC
TAILGATE SPREADER



MAGNUMTM
SPREADERS

TABLE OF CONTENTS

Safety Instructions -----	3-5
Control Electric Specifications & Installation -----	6
Harness and Wiring Diagram -----	7-9
Trough mounting instructions-----	11-17
Spinner Assembly and Installation -----	18-19
Spinner Spread Pattern Instructions -----	20-21
Operating Instructions -----	22-24
Recommended Regular Maintenance -----	25
Assembly Parts Drawing & Parts List -----	26-32
Spinner Assembly Parts Drawing & Parts List -----	33-35
Name Plate Information -----	36
Warranty -----	37

SAFETY PRECAUTIONS

The best safety device is a careful operator!



This symbol means ATTENTION!
Become Alert!
Your safety is involved!
Please read and understand completely before operating!



Improper use of this equipment can result in serious injury. To reduce this possibility, give complete and undivided attention to the job at hand, and follow these safety precautions.

Preparation

Know your controls. Read this instruction manual. Learn how to stop the equipment quickly in an emergency.

Do not allow children to operate machine; nor adults to operate it without proper instructions.

Keep all individuals not involved in the use of the equipment a safe distance away.

Operation

Always check area around machine before operating controls.

Always wear relatively tight and belted clothing when operating equipment. Loose jackets, shirts, sleeves or other loose clothing should not be worn because of the danger of catching them in moving parts or controls.

Stop and inspect equipment if unusual movement, sounds or noises are observed. Repair damage before restarting and operating the equipment.

Disengage power to all operating equipment: (1) before leaving operator's position, (2) before making any repairs, adjustments, or cleaning, or (3) when not in use.

Take all possible precautions when leaving the equipment unattended; shifting the vehicle out of gear, setting parking brake, shutting off engine and removing key.

NOTICE:

It is the responsibility of the owner of this spreader to replace any or all safety decals which become unreadable or otherwise defaced, and to apply the new decals to the spreader in a secure manner in the same location as the old decals.

Read and observe all **“DANGER”** and **“CAUTION”** safety decals appearing on equipment.

The following safety decals appear in various locations on your equipment. The sizes of the decals shown in this manual have been reduced in order to save space. Refer to page 4 for location and size of safety decals on your equipment.

NOTICE!

Your spreader is equipped with a safety interlock device. This device must be disconnected before the spreader trough bottom door and the spreader trough top cover can be opened exposing the auger. This device positively disconnects all electric power from the auger drive motor to prevent accidental bodily injury due to contact with a turning auger.



This decal appears on the left end, or the right end of the spreader trough. It cautions all to observe general safety procedures when operating this equipment.

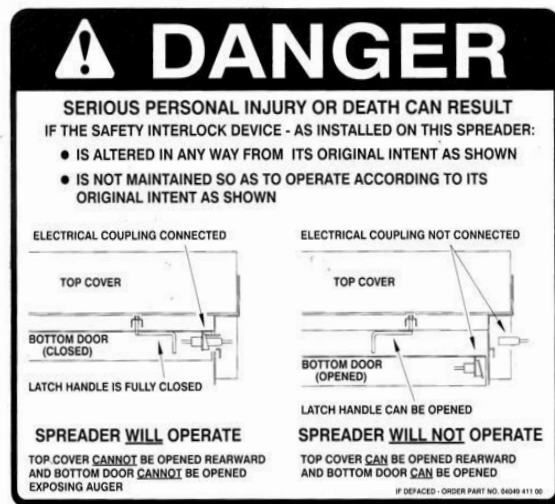

This decal appears on the back of the spreader cover plate at the right end of the spreader. It alerts all to the danger associated with the improper use of the Safety Interlock Device.



This decal appears on the back of the spreader trough cover plate. It alerts all to the danger of being caught in the dropout opening or from the top of the spreader trough where serious personal injury could result.



This decal appears near the spinner assembly on the back of the spreader trough cover plate. It alerts all to the danger of being struck by material being spread by the spinner assembly which could result in serious personal injury.

RTEL INSTALLATION AND OPERATING INSTRUCTION MANUAL

SAFETY DECAL LOCATIONS WITH PARTS LIST

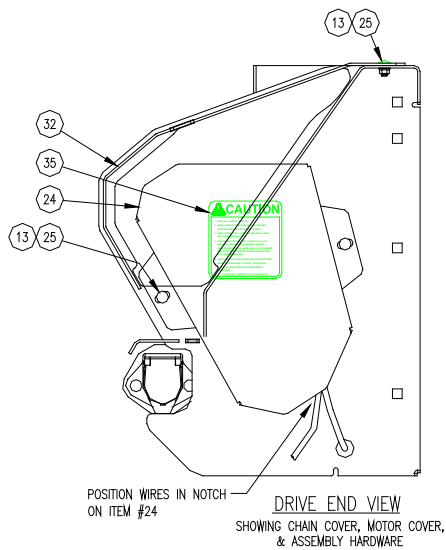
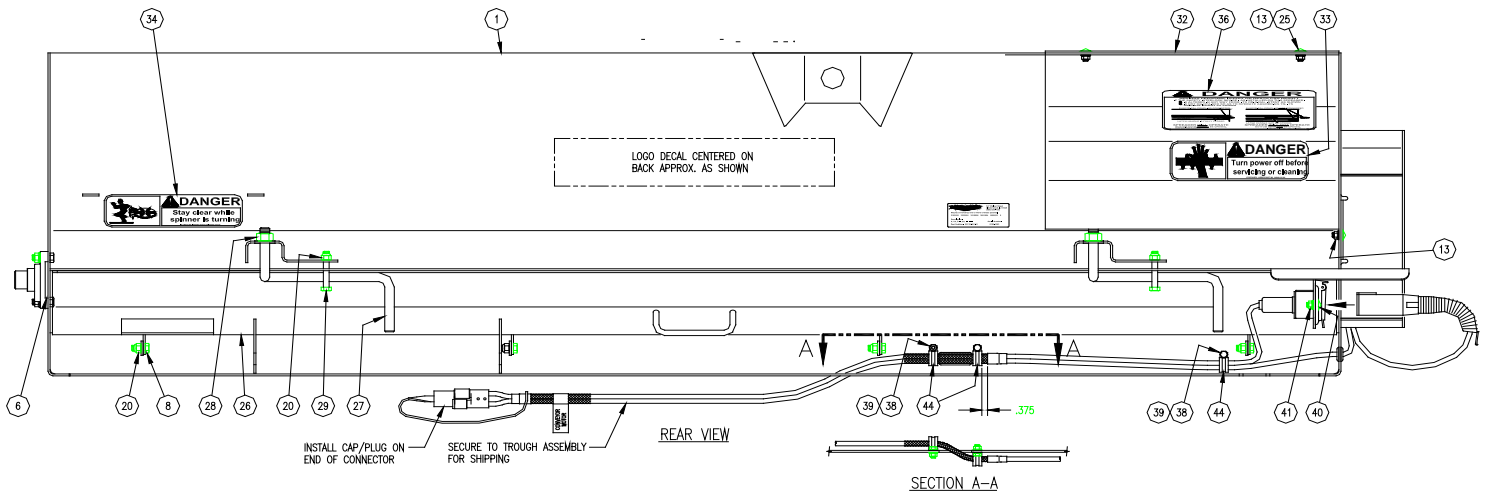

ITEM	PRODUCT	QTY	DESCRIPTION
33	62515	1	DECAL, DANGER (AUGER) (9 X 2 3/4")
34	62006	1	DECAL, DANGER (SPINNER) (9 X 2 3/4")
35	62007	1	DECAL, CAUTION (4 1/4 X 4 ")
36	63961	1	DECAL, SAFETY INTERLOCK ELEC.

ELECTRIC CONTROL SPECIFICATIONS AND INSTALLATION ELECTRIC CONTROL PANEL 63962 W/ SYSTEM SPECIFICATIONS

SPECIFICATIONS:

- UNIT TYPE.....DUAL VARIABLE SPEED CONTROLLER
- OPERATING VOLTAGE.....12V DC
- DUTY.....CONTINUOUS ALL SETTINGS
- CAPABILITY.....EACH CIRCUIT TO CONTROL 1/2 HP (MINIMUM) DC MOTOR
- INITIAL STARTUP.....GO STRAIGHT TO "BLAST" MODE FOR SEVERAL SECONDS;
RETURN TO EXISTING DIAL SETTINGS
- OVERLOAD PROTECTION.....80 AMPS (FOR EITHER CIRCUIT, OR TOTAL)
- CONTROLS.....KNOB STYLE DIALS & ROCKER SWITCHES

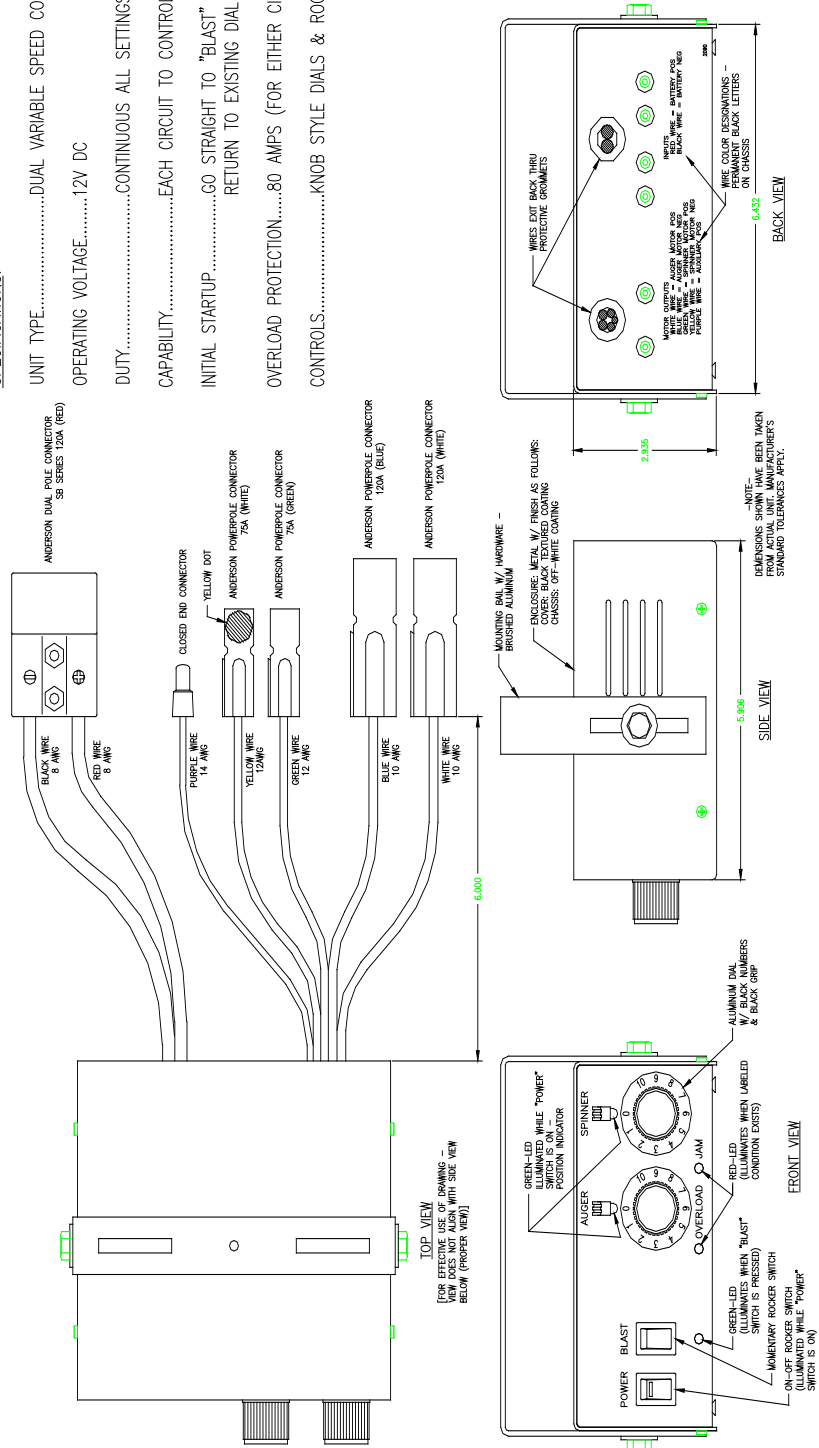

ELECTRIC CONTROL INSTALLATION (Continued)

ELECTRIC WIRING HARNESS

63963

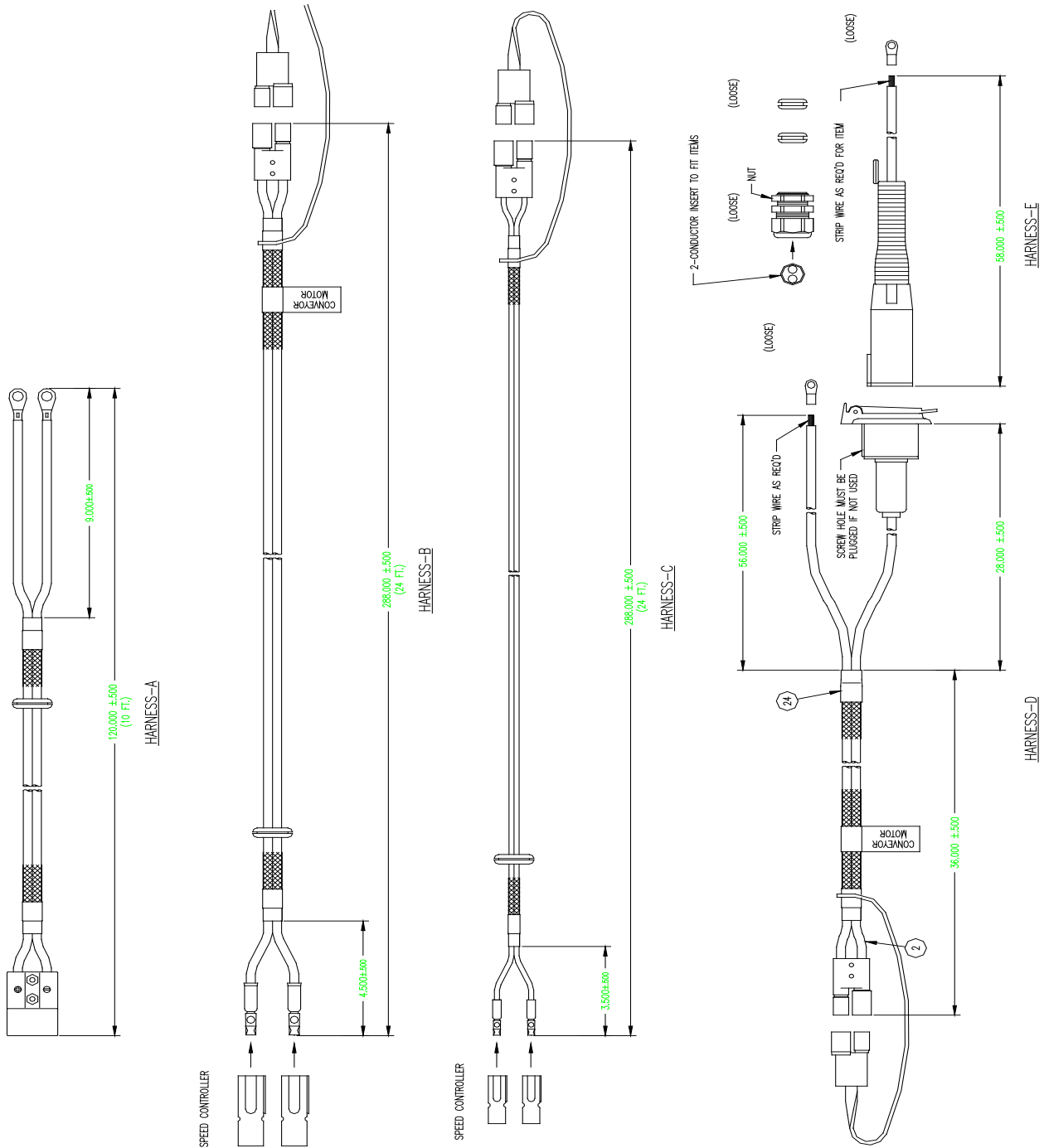

RTEL INSTALLATION AND OPERATING INSTRUCTION MANUAL

DRIVE END VIEW WIRING HARNESS ROUTING

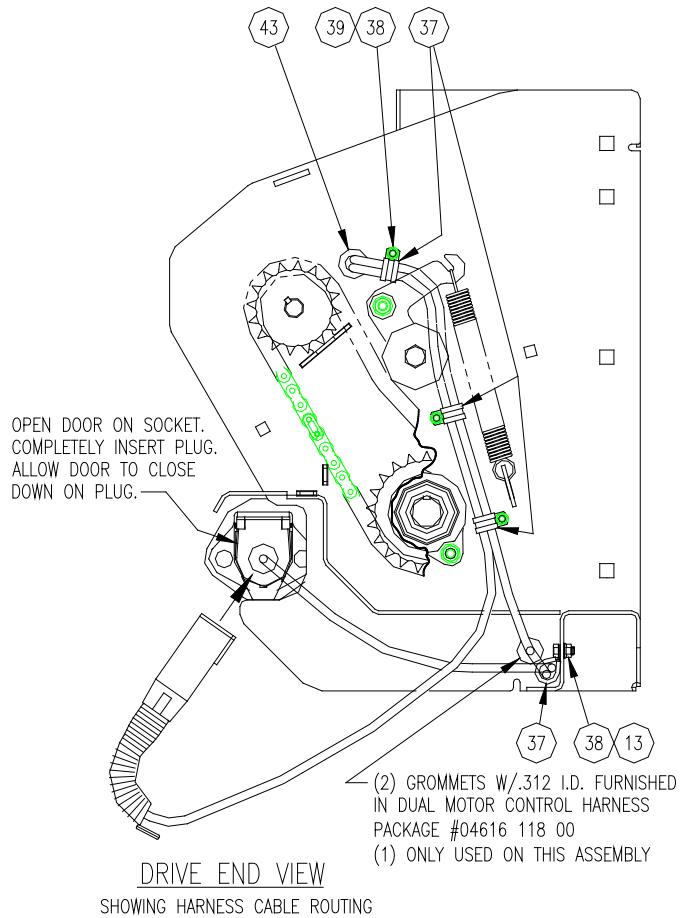

DRIVE END PARTS LIST

ITEM	PRODUCT	QTY	DESCRIPTION
13 CS	62611	10	NUT, 3/8-16 SERRATED FLANGE ZP
SS	62743	10	NUT, 3/8-16 SERRATED FLANGE SS
37	62652	3	CLAMP, CUSHIONED 1/2" LOOP SS
38 CS	20003	6	BOLT, 1/4-20 X 3/4" HH G5 ZP
SS	62189	6	BOLT, 1/4-20 X 3/4" HH SS
39 CS	62187	6	NUT, 5/16-18 SER FLANGE ZP
SS	62690	6	NUT, 5/16-18 SER FLANGE SS
43	63964	1	GROMMET, 5/8 ID

NOTES

THIS PAGE INTENTIONALLY LEFT BLANK

THIS PAGE INTENTIONALLY LEFT BLANK

RTEL INSTALLATION AND OPERATING INSTRUCTION MANUAL

INSTALLATION OF SPREADER MODEL RTEL (78" INSIDE WIDTH) ON DUMP BODY WITH 78" INSIDE BODY WIDTH



DANGER

SUPPORT SPREADER AND OTHER HEAVY COMPONENTS SOLIDLY WHEN POSITIONING FOR MOUNTING ON TRUCK DUMP BODY.

1. Remove tailgate from dump body. Upper hinge pins will be used for spreader mounting.
2. Position spreader against rear of dump body with trough lip approximately 1/4" **above** dump body floor. Center spreader side to side. Temporarily clamp spreader in place.
3. Using upper tailgate hinge pins, install furnished upper hinge brackets into offset hinges on dump body. Select either 1" or 1 1/4" hole size (depending on hinge pin diameter) at end of brackets. Cut off unused end if desired. Align hinge brackets squarely with offset hinge plates on dump body.
4. Measure space between hinge brackets and spreader end plates, and add spacers as necessary (not furnished). Tack weld in place.
5. Clamp furnished lower latch pins in dump body latches. Push pins against end plates of spreader. Mark required length of pins, remove and saw off excess. Reposition latch pins in body latches. Tack weld in place if accessible, or accurately mark location of pins on end plates for repositioning when welding is accessible.
6. Remove spreader from dump body and finish welding hinge brackets and lower latch pins in place. (Keep in mind that spreader replaces tailgate, so it will be necessary to retain same strength at attachment points on spreader as attachment points on tailgate.) Remove all clamps.
7. Reattach spreader to dump body for spinner installation.

RTEL INSTALLATION AND OPERATING INSTRUCTION MANUAL

INSTALLATION OF SPREADER MODEL RTEL (78" INSIDE WIDTH) ON DUMP BODY WITH 78" INSIDE BODY WIDTH

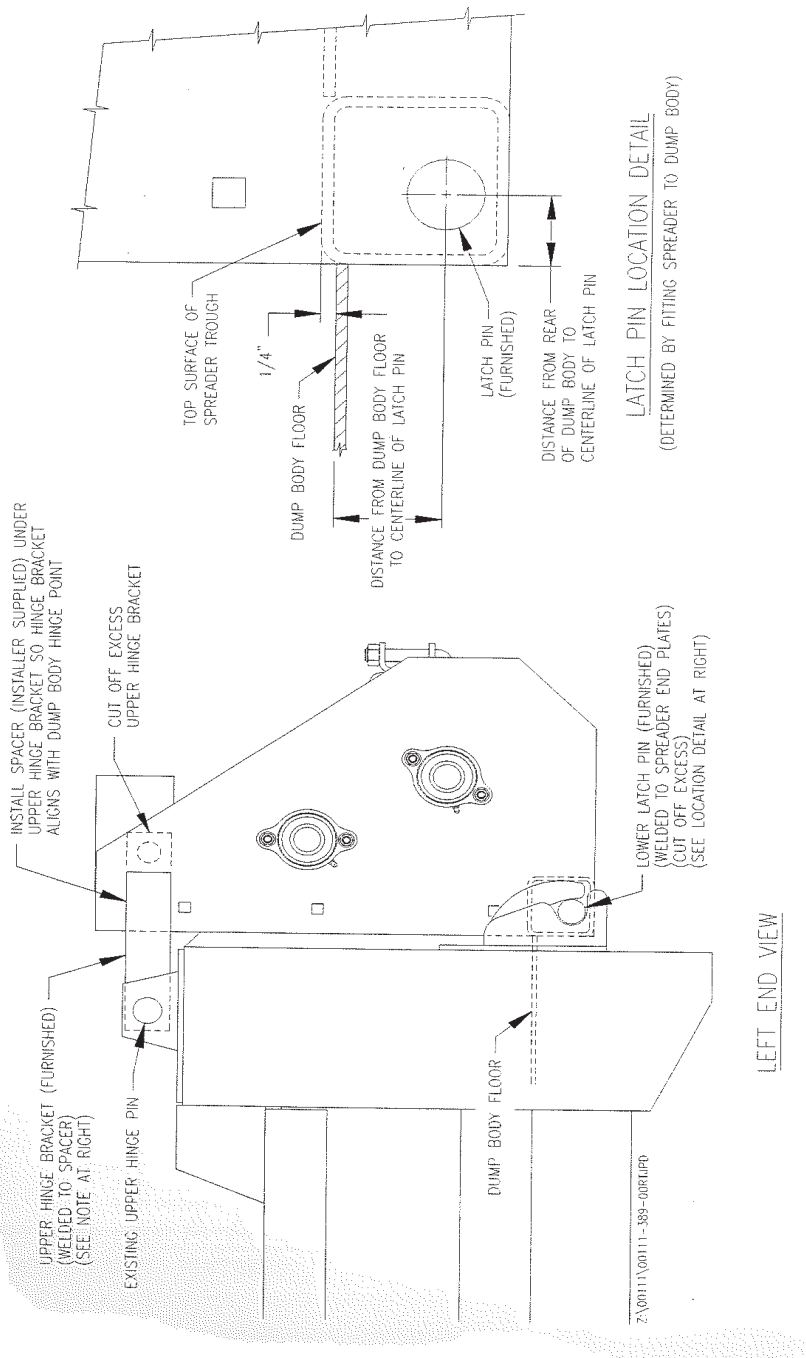

LATCH PIN LOCATION DETAIL
(DETERMINED BY FITTING SPREADER TO DUMP BODY)

NOTE: ALL INFORMATION SHOWN AT THIS LEFT END ALSO APPLIES TO RIGHT END

RTEL INSTALLATION AND OPERATING INSTRUCTION MANUAL

INSTALLATION OF SPREADER MODEL RTEL (78" INSIDE WIDTH) ON DUMP BODY WITH GREATER THAN 78" INSIDE BODY WIDTH USING WIDTH EXTENDERS



DANGER

SUPPORT SPREADER AND OTHER HEAVY COMPONENTS SOLIDLY WHEN POSITIONING FOR MOUNTING ON TRUCK DUMP BODY.

NOTE: The following instructions apply to spreader installation on a low sided contractor body. If spreader is to be installed on a body with corner post which are higher than spreader, it will be necessary for installer to improvise additional upper hinge bracket attachment ironwork.

1. Remove tailgate from dump body. Upper hinge pins will be used for spreader mounting.
2. With 1/2" x 1" carriage bolts and flange nuts attach width extenders to ends of spreader. Lefts and rights have been furnished; use extender at each end which aligns with all four square holes. allow to remain loose for STEP 3 below
3. Position spreader against rear of dump body with trough lip approximately 1/4" above dump body floor. Center spreader side to side. Temporarily clamp spreader in place. Tighten hardware.
4. Select end of furnished upper hinge bracket, which fits existing upper hinge pin, and position within upper hinge plates on dump body. Butt other end against extenders. Measure distance from center of hole in hinge bracket to center of hole in body hinge. Saw this amount off unused end of hinge bracket.
5. Reinstall sawed-off hinge brackets. With hinge pins squarely aligned with body hinge plates on dump body, tack weld in place.
6. Align furnished gusset on upper end of each width extender for additional support. Tack weld in place. If width extenders must be lengthened at top in order for hinge brackets to be attached, additional gussets may be added for more upper support. Tack weld in place.
7. Position another furnished gusset at lower end of width extender for additional support. Tack weld in place. If width extenders must be lengthened at top in order for hinge brackets to be attached, additional gussets may be added for more support. Tack weld in place.
8. Clamp furnished lower latch pins in dump body latches. Push pins against end plates of spreader. Mark required length of pins, remove and saw off excess. Reposition latch pins in body latches. Tack weld in place if accessible, or accurately mark locations of pins on end plates for repositioning when welding is accessible.
9. Remove spreader from dump body and finish welding hinge brackets, gussets and lower latch pins in place. (Keep in mind that spreader replaces tailgate, so it will be necessary to retain same strength at attachment points on spreader as attachment points on tailgate.) Remove all clamps.
10. Reattach spreader to dump body for easier spinner installation.

RTEL INSTALLATION AND OPERATING INSTRUCTION MANUAL

INSTALLATION OF MODEL RTEL (78" INSIDE WIDTH) ON DUMP WITH GREATER THAN 78" INSIDE BODY WIDTH USING WIDTH EXTENDERS

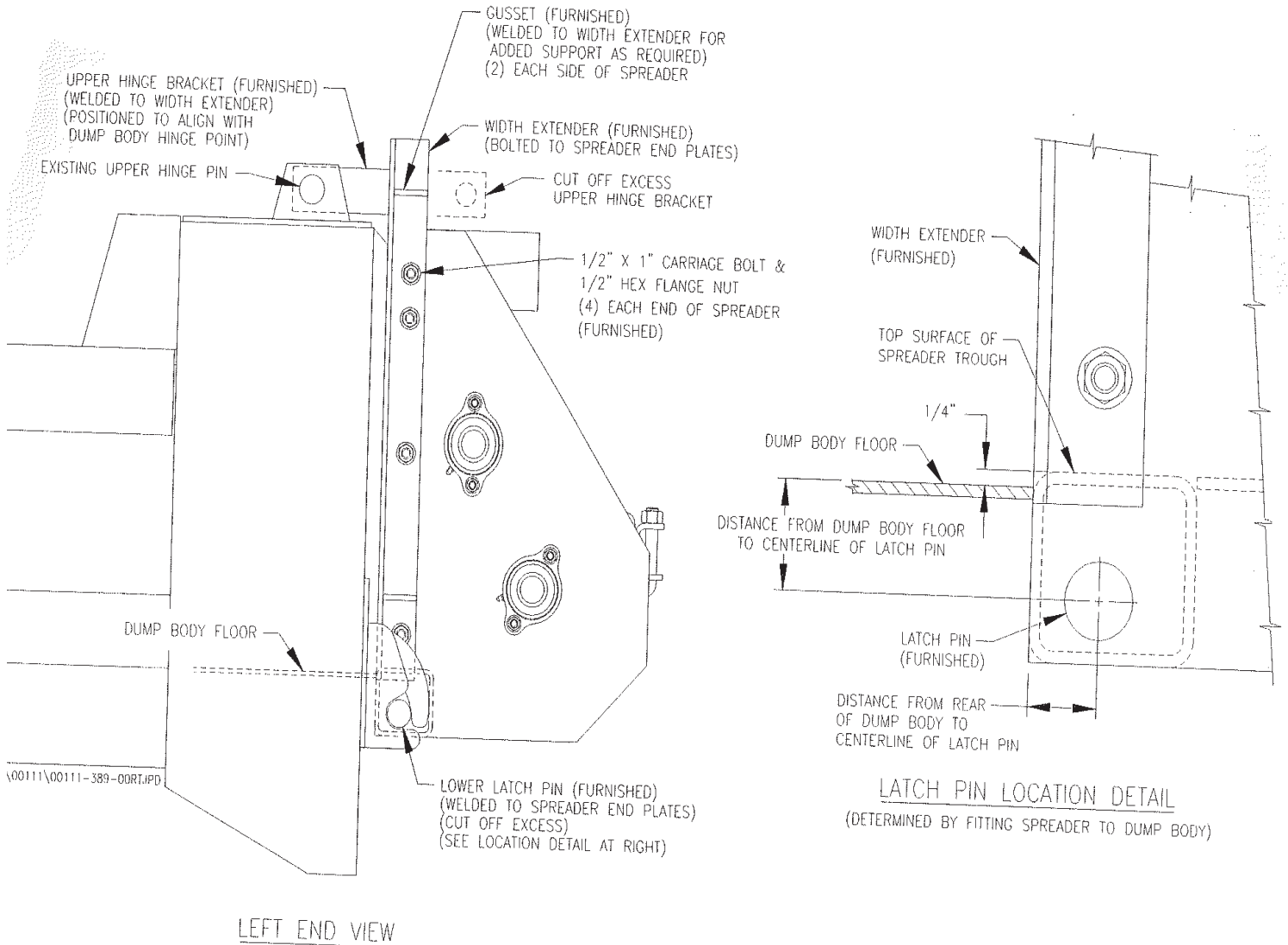

NOTE: ALL INFORMATION SHOWN AT THIS LEFT END
ALSO APPLIES TO RIGHT END

RTEL INSTALLATION AND OPERATING INSTRUCTION MANUAL

INSTALLATION OF SPREADER HEIGHT EXTENSION WELDMENT ON MODEL RTEL-84 TROUGH (84" INSIDE WIDTH) with INSTALLATION OF EXTENDED UNIT ON DUMP BODY (FOR 34" AND 47" UNITS)



DANGER

SUPPORT SPREADER AND OTHER HEAVY COMPONENTS SOLIDLY WHEN POSITIONING FOR MOUNTING ON TRUCK DUMP BODY.

1. Place spreader assembly in upright position in shop work area. (Having spreader on dump body for installation of height extension may make installation more difficult.)
2. Position extension weldment on top edge of spreader through so flat side faces forward. Ends of extension weldment should be flush with ends of spreader, and front surfaces of weldment should be flush with front edges of spreader end plates. Clamp in place
3. Position furnished vertical brace tubes against each end of spreader, and butt up against underside of protruding flange at top of extension weldment. For a tight fit against back of dump body, utilize brace tubes to align extension weldment with front edges of spreader end plates. Clamp in place
4. Tack weld extension weldment and vertical brace tubes to spreader.
5. At this point some consideration might be given to the next step. If the spreader is going to be immediately installed on a dump body, finish welding would not be necessary until spreader mounting components have been positioned and finalized. If spreader is not going to be immediately installed on a dump body, then Step #6 may be incorporated.
6. Finish welding all added components to spreader. To reduce corrosion at joints, and especially at lapped joints, it is recommended that all welds be continuous and approximately equal to thinnest material in joint.
7. Remove tailgate from dump body. Upper hinge pins will be used for spreader mounting.
8. Position spreader against rear of dump body with trough lip approximately 1/4" above dump body floor. Center spreader side to side. Temporarily clamp spreader in place.
9. Using upper tailgate hinge pins, install furnished upper hinge brackets into offset hinges on dump body. Select hole size at end of brackets which fits existing hinge pin, and align squarely within offset hinge plates. Hinge brackets should lap ends of extension weldment.
10. Measure space between hinge brackets and ends of extension weldment, and add spacers as necessary (not furnished). Tack weld in place.
11. Clamp furnished lower latch pins in dump body latches. Push pins against vertical brace tubes. Notch or cut off ends of vertical brace tubes so pins may butt against spreader end plates. Mark required length of pins, remove and saw off excess. Reposition pins in body latches. Tack weld in place if accessible, or accurately mark location of pins on end plates for repositioning when welding is accessible.
12. Remove spreader from dump body and finish welding hinge brackets and lower latch pins. (Keep in mind that the spreader replaces tailgate, so it will be necessary to retain same strength at attachment points on spreader as attachments points on tailgate.) Also finish welding extension weldment and vertical tubes if not already done. Remove all clamps.
13. Reattach spreader to dump body for spinner assembly installation.

RTEL INSTALLATION AND OPERATING INSTRUCTION MANUAL

INSTALLATION OF SPREADER HEIGHT EXTENSION WELDMENT ON MODEL RTEL (84" INSIDE WIDTH)

with INSTALLATION OF EXTENDED UNIT ON DUMP BODY

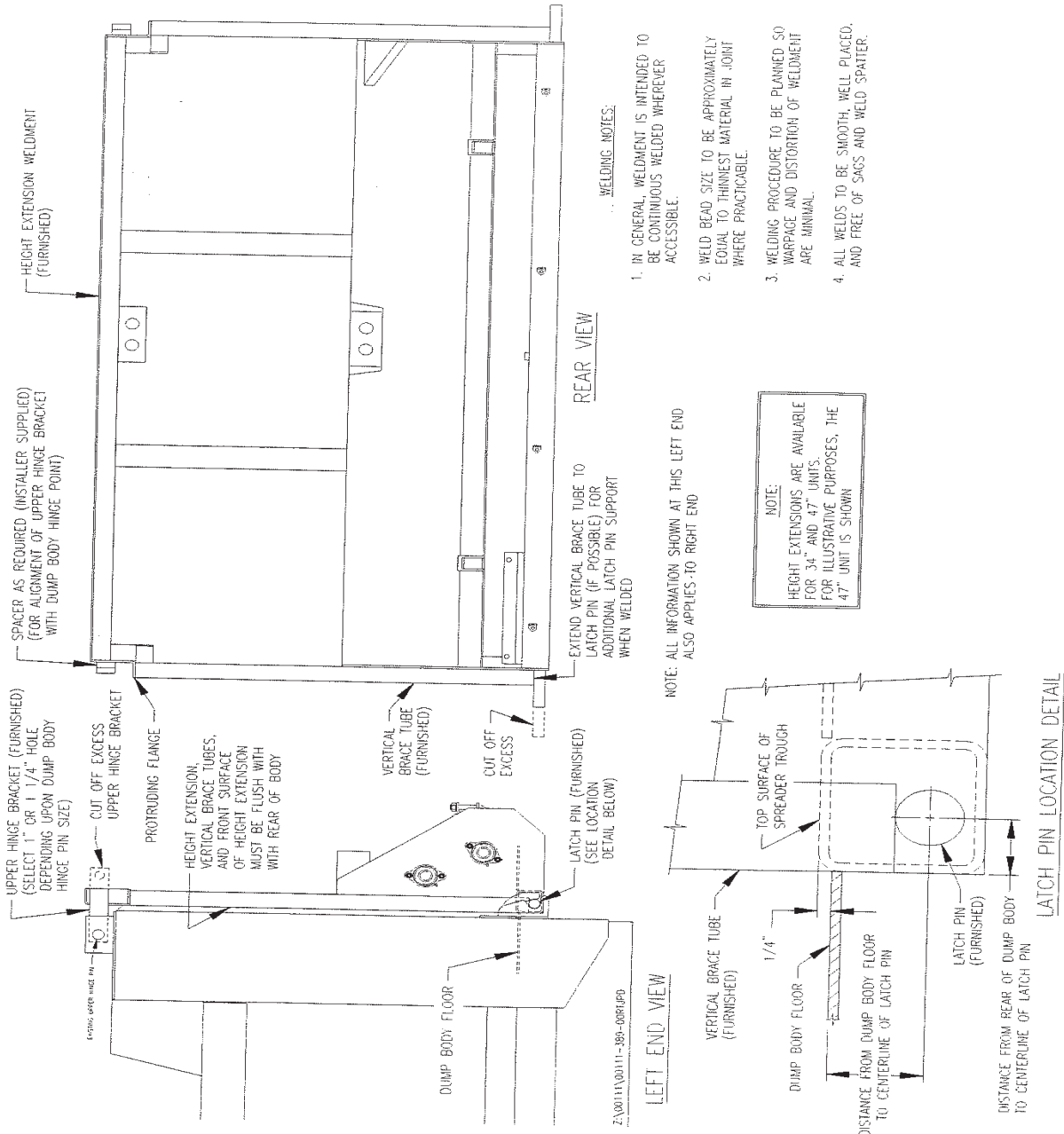

RTEL INSTALLATION AND OPERATING INSTRUCTION MANUAL

SPREADER ATTACHMENT & RTEL HEIGHT EXTENSIONS

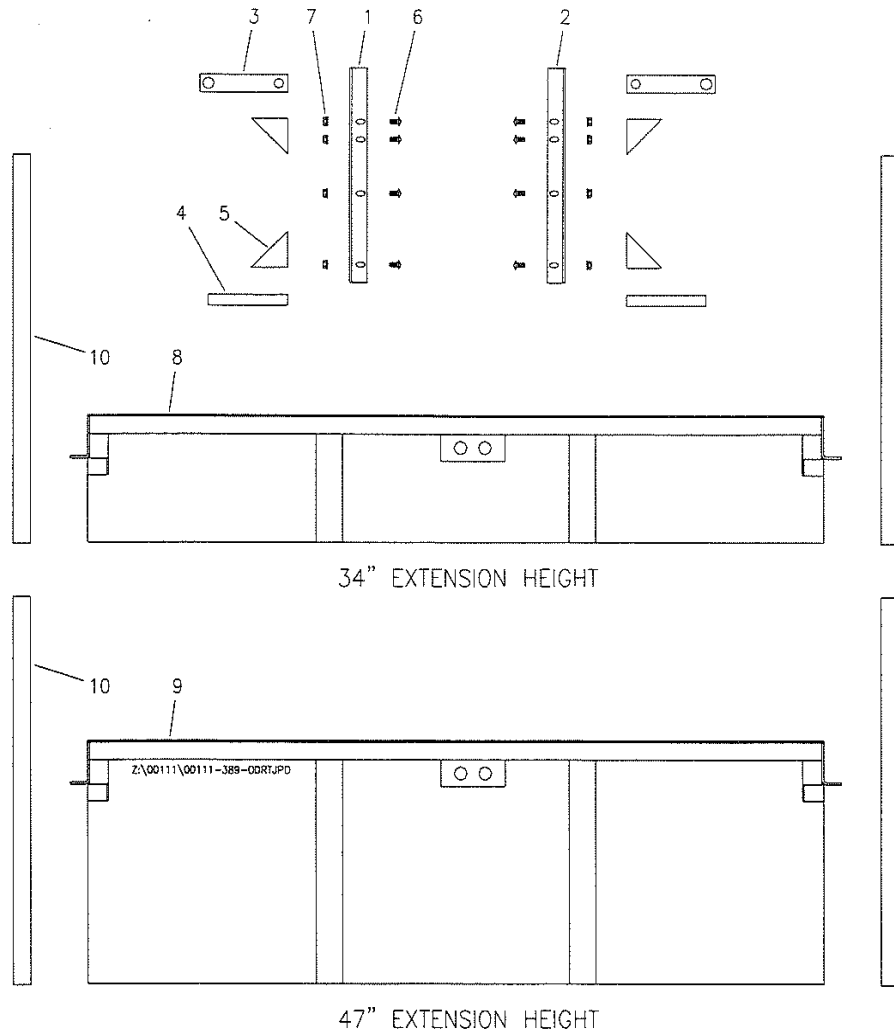

ITEM	PART NUMBER	QTY	DESCRIPTION
1	63965	1	EXTENSION, L.H. FORMED (CARBON STEEL)
S2	63966	1	EXTENSION, L.H. FORMED (STAINLESS STEEL)
2	63967	1	EXTENSION, R.H. FORMED (CARBON STEEL)
S2	63968	1	EXTENSION, R.H. FORMED (STAINLESS STEEL)
3	63969	2	BRACKET, HINGE
4	63970	2	PIN, LOWER LATCH
5	63971	4	PLATE, GUSSET (CARBON STEEL)
S2	63972	4	PLATE, GUSSET (STAINLESS STEEL)
6	*	8	BOLT, 1/2"-13 X" CARRIAGE (SHORT NECK)
7	*	8	NUT, 1/2"-13 SERRATED FLANGE
8	63973	1	WELDMENT, EXTENSION, RTJ-34 (CARBON STEEL)
S2	63974	1	WELDMENT, EXTENSION RTJ-34 (CARBON STEEL)
9	63975	1	WELDMENT, EXTENSION RTJ-47 (CARBON STEEL)
S2	63976	1	WELDMENT, EXTENSION RTJ-47 (STAINLESS STEEL)
10	63977	2	TUBE, EXTENDER (CARBON)
S2	63978	2	TUBE, EXTENDER (STAINLESS STEEL)

INSTALLATION OF SPINNER ASSEMBLY ON “RTEL” SERIES SPREADERS



DANGER

SUPPORT SPINNER ASSEMBLY SOLIDLY WHEN MOUNTING ON SPREADER.

SPINNER ASSEMBLY PROCEDURE:

1. Install spinner motor onto spinner frame using 3/8-16 x 1 1/4" bolts serrated flange nuts.
2. Attach spinner disc to hub with 5/16" x 1 1/2" bolts, flatwashers and flange nuts.
3. Apply anti-seize compound to spinner motor shaft.
4. Mount spinner disc/hub assembly on spinner motor shaft.
5. Secure disc/hub assembly to motor shaft with proper size hardware (provided).
6. While holding lock collar in middle notch of spinner extension mounting bracket, slide spinner hinge rod through both the mounting bracket and lock collar.

MOUNTING PROCEDURES:

TRUCK SHOULD BE ON LEVEL SURFACE.

1. Install spinner assembly on spreader by sliding the hinge rod into the mounting tabs on bottom door. Insert (2) keeper pins into hinge rod. Center and lock spinner assembly between mounting tabs.
2. Raise and lower dump body to check spinner ground clearances.

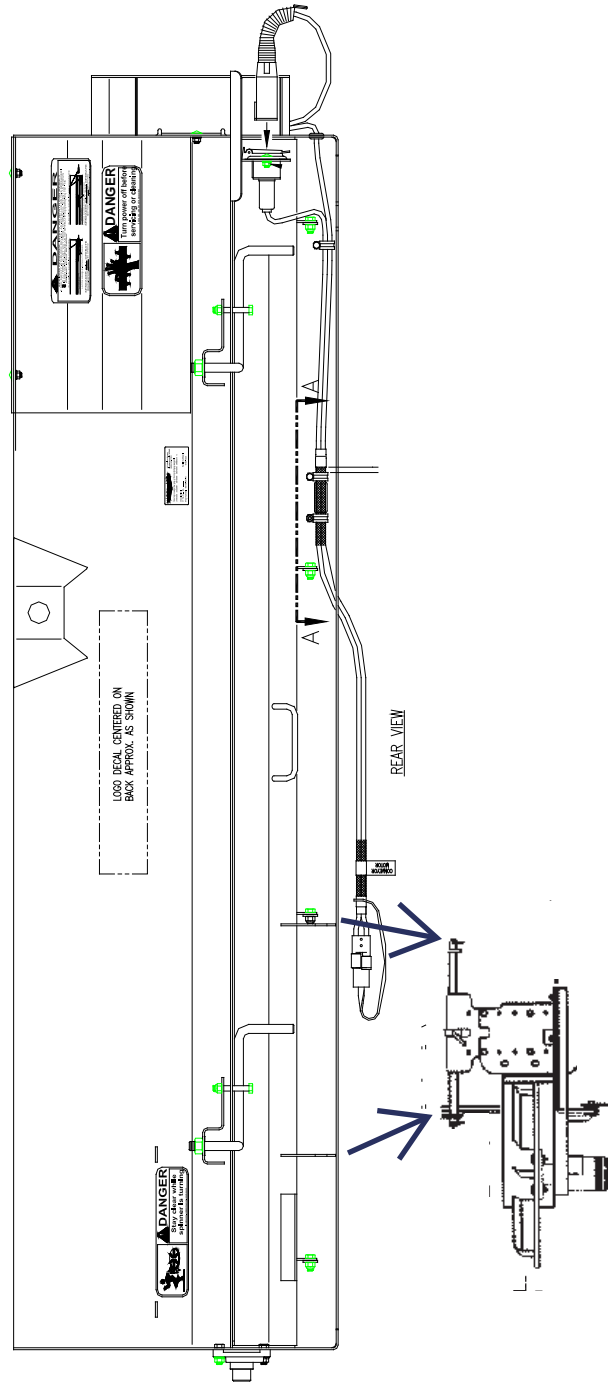

**SPINNER DRAWING FOR LOCATION REFERENCE ONLY
ON A LEFT HAND MOUNTED SPREADER.**

ADJUSTING SPINNER FOR DESIRED SPREAD PATTERN



DANGER!

Serious personal injury can result from being caught in a turning spinner. Stay clear and keep all others clear when spinner is turning.

Serious personal injury can result if hit by flying particles being thrown by a turning spinner.

Stand back, and keep all others back at least 50 feet while spinner is turning. **DO NOT ASSUME that particles cannot be thrown by a turning spinner just because material is not being dropped onto the spinner; particles that have been sticking to the spinner may suddenly come loose and be thrown causing possible injury.**

In general, for the most commonly desired spread patterns, the material drop zone should be **over forward half** and **within outside edge of disc**. See below and next page. Adjusting the specific location where material falls on the forward half of the spinner disc is very important. This allows the greatest portion of the material to be placed on the road surface in the three most commonly desired locations: 1. To the left of the vehicle. 2. To the left and rear of the vehicle. 3. To the rear and right of the vehicle.

The spinner shield which is positioned approximately at the right forward quadrant of the spinner disc, is intended to restrict "stray" material to the spinner area and to aid in a more defined spread pattern.

Once the desired spread pattern has been obtained, increasing the spinner speed by opening the spinner control knob will give a wider spread pattern, and closing the spinner control knob will give a narrower spread pattern.

It should be noted that the spread pattern width will vary as the dump body is raised and lowered during spreading operations. This is due to the spinner becoming closer to the road surface as the body is raised, and farther away from the road surface as the body is lowered. A higher spinner assembly above the road surface will give a wider spread pattern, and a lower spinner assembly above the road surface will give a narrower spread pattern. When establishing spread pattern width, raise the body to the dump angle normally used during spreading operations, and have the spinner control knob at the setting normally used during spreading operations.

Sliding the spinner to intermediate positions from those shown below and on the following page will give variations of spread patterns to those shown. After establishing the desired spread pattern, it is suggested that the spinner position on the hinge rod, the dump body angle, and the valve spinner control setting be recorded for future use.

IMPORTANT! After making final adjustments, the spinner assembly must always be locked in position using the provided locking mechanism.

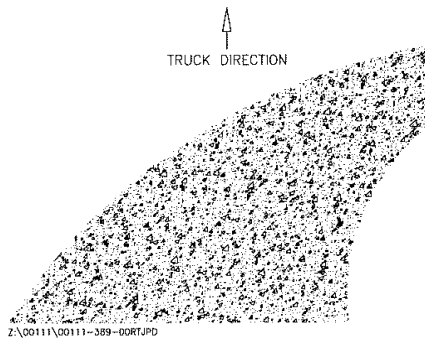
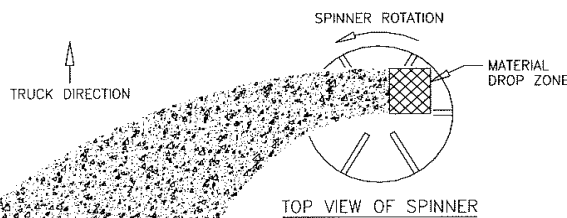
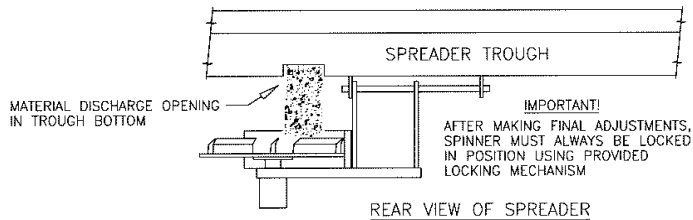

BULK OF MATERIAL IS SPREAD TO LEFT SIDE OF TRUCK WHEN SPINNER IS SLID TO FAR LEFT POSITION (AS SHOWN ABOVE). (DROP ZONE IS OVER RIGHT-FORWARD AREA OF SPINNER DISC)

SPREAD PATTERN RESULTING FROM SPINNER IN FAR LEFT POSITION

Z:\00111\00111-389-00RTJPD

Spread pattern adjustment, cont'd

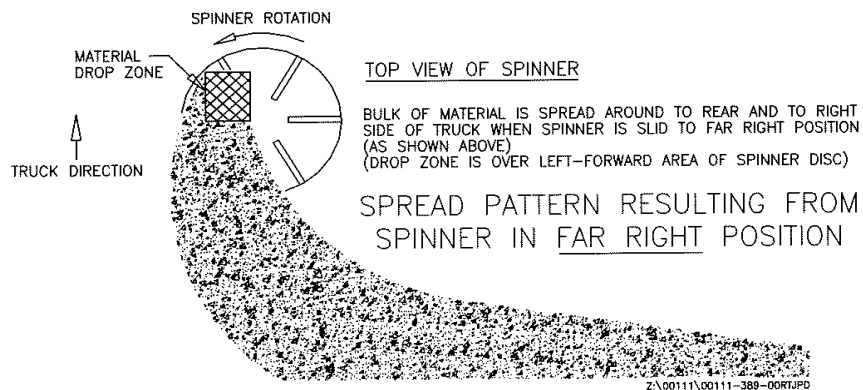
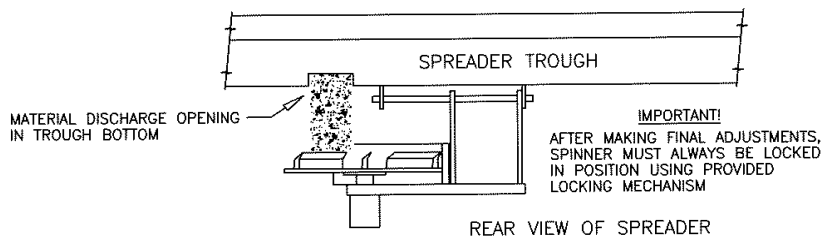
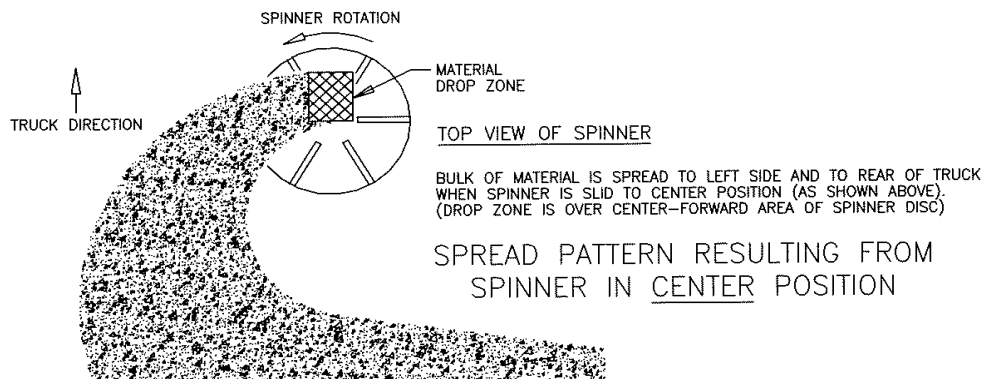
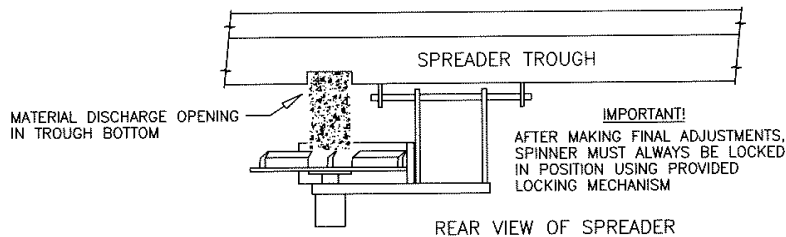

OPERATING INSTRUCTIONS

DANGER

1. WHEN STARTING UP NEW EQUIPMENT, BE SURE EVERYONE IS STANDING CLEAR, WATCH FOR ANYTHING THAT MAY REQUIRE SHUTTING SYSTEM DOWN. EQUIPMENT MUST BE STARTED UP SLOWLY AND WATCHED FROM A SAFE DISTANCE. WATCH FOR ANYTHING THAT MAY BE HITTING SOMETHING THAT IT SHOULD NOT BE HITTING, AND LISTEN FOR SOUNDS THAT ARE ABNORMAL. CORRECT ANYTHING THAT IS ABNORMAL BEFORE CONTINUING USE OF THE EQUIPMENT.
2. BEFORE INSTALLATION, MAINTENANCE, CLEANING, OR REMOVAL OF SPREADER, ALL ELECTRICAL CONNECTIONS MUST BE DISCONNECTED

INITIAL START UP:

This spreader is equipped with a electric safety interlock device designed to interrupt electrical flow to the auger motor when disconnected. The spreader is shipped with the interlock device in the disconnected position and must be connected for operating the spreader.

1. Connect electrical harnesses to safety interlock, spreader and spinner.
2. Keep auger and spinner knobs on controller to zero position.
3. Push power switch to "ON" position.
4. Examine auger and spinner to see if they are functioning properly. (They will be operating slowly.)
(Left hand mounted spinner should turn in CCW rotation as viewed from above spinner.,
Auger should turn in direction which makes auger fliting appear to move towards trough dropout opening.)
5. Adjust control knobs to other positions and check to see if spinner and auger operate faster as knobs are opened, and slower as knobs are closed.
6. Open knobs to other positions and check to see if spinner and auger operate faster as knobs are adjusted.
7. Shut power switch to off

OPERATING INSTRUCTIONS

(Continued)

PREPARING SPREADER FOR USE:

1. Loosen spinner lock and slide spinner assembly to far left and retighten lock. (Position for spreading three or four lane highway from right lane.)
2. Put spreading material in dump body and raise dump body to fill spreader trough.
3. Lower dump body to safe position.
4. Press controller power switch to "ON" position. Spread small amount of material to determine placement of material at various spinner and auger speeds with spinner in this far left position.
5. Press controller switch to "OFF" position and shut off truck engine.
6. Loosen spinner lock and slide spinner assembly to far right and retighten lock. (Position for spreading behind truck and to extreme right covering up to four lanes from left lane.)
7. Start truck engine.
8. Press controller switch to "ON" position. Spread small amount of material to determine placement of material at various spinner and auger speeds with spinner in this far right position.
9. It should now be visible that various spread patterns may be obtained by placing spinner at various positions from left to right, and by changing spinner speeds on valve.

OPERATING SPREADER:

1. For operating electrical system, follow same procedures as for preparing spreader for use.
2. Any speed knob setting changes may be made while truck is in motion.
3. Spinner and auger may be stopped at the same time, without changing their valve settings, by pressing power switch to "OFF" position.
4. For normal use of dump truck, cover plate may be laid flat over spreader trough and locked in place. Dump body tailgate may be opened from top or bottom.
5. When using truck for normal hauling and dumping, it is recommended that electrical safety interlock be disconnected. Push dust cap onto disconnect.
6. Refer to safety interlock danger decal on trough cover plate for proper use of safety interlock.
7. To avoid spinner damage, spinner may be removed when truck is used for extensive hauling. Protect electric disconnects with appropriate plugs and caps.

NOTE:

If remaining load in dump body is to be unloaded with the spreader attached to the dump body, disconnect the electrical harness. This will allow the spreader to swing away from the back of the dump body as body is raised.

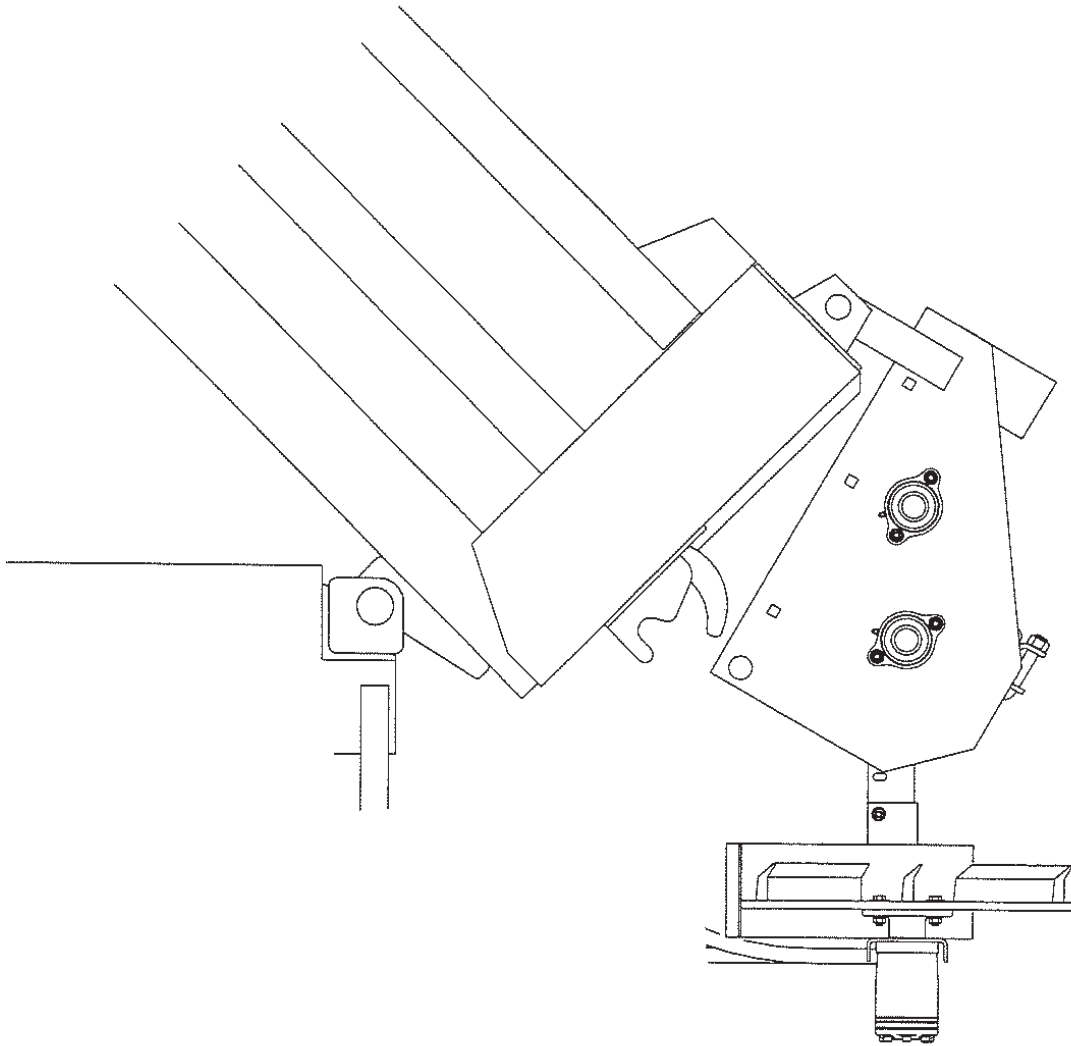

DANGER

SERIOUS PERSONAL INJURY CAN RESULT FROM BEING CAUGHT IN A TURNING AUGER, A TURNING SPINNER, OR OTHER OPERATING TRUCK EQUIPMENT. BEFORE PERFORMING MAINTENANCE OPERATIONS, PARK VEHICLE ON LEVEL GROUND. SET PARKING BRAKE, SHUT OFF ALL POWER, AND SHUT OFF TRUCK ENGINE. ALWAYS REPLACE SHIELDS AND COVERS WHEN MAINTENANCE IS COMPLETE.

1. Clean electrical plugs before taking apart or connecting.
2. Protect electrical plugs while in use and after taking apart with dust caps or other suitable protection.
3. Auger bearing requires periodic greasing every 15 hours of use and more frequent greasing during periods of greater use.
4. Greasing spinner hinge rod at support pivot points is suggested.
5. Hosing down and cleaning spreader after each use, and repainting or oiling after each season will greatly prolong spreader life. To open bottom door and top cover, disconnect electrical safety interlock and pivot around to end of spreader.
6. Spreader trough should be completely emptied after each use during severe cold weather to prevent material from freezing around auger.

PARTS LISTING

FRONT VIEW SHOWN

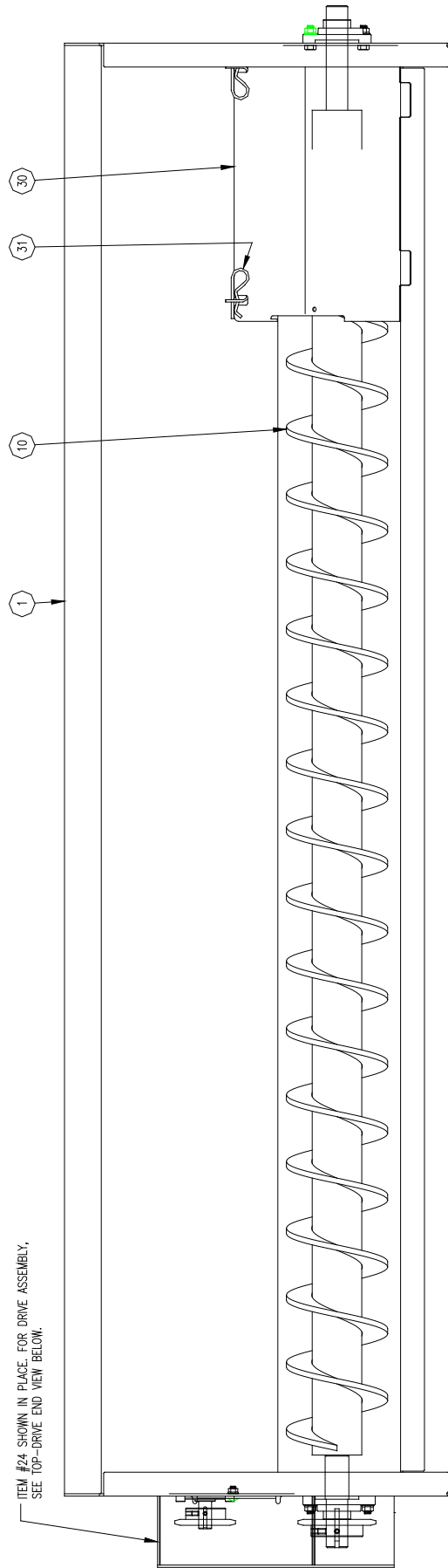

RTEL INSTALLATION AND OPERATING INSTRUCTION MANUAL

FRONT VIEW PARTS LISTING

ITEM	PART NUMBER	QTY	DESCRIPTION
1 CS	63979	1	WELD, TROUGH, 10 GA CS 78"
S2	63980	1	WELD, TROUGH, 10 GA S2 78"
CS C/D	63981	1	WELD, TROUGH, 10 GA CS 78" CENTER DROP
S2 C/D	63982	1	WELD, TROUGH, 10 GA S2 78" CENTER DROP
CS	63983	1	WELD, TROUGH, 10 GA CS 84"
S2	63984	1	WELD, TROUGH, 10 GA S2 84"
CS C/D	63985	1	WELD, TROUGH, 10 GA CD 84" CENTER DROP
S2	63986	1	WELD, TROUGH, 10 GA S2 84" CENTER DROP
10	62490	1	WELD, AUGER, RTJ (FOR 78" SPREADER)
C/D	62727	1	WELD, AUGER, RTJ CENTER DROP (FOR 78")
	63987	1	WELD, AUGER, RTJ-XL (FOR 84" SPREADER)
C/D	63988	1	WELD, AUGER, RTJ-XL CENTER DROP (FOR 84")
30 C/D	63989	1	COVER, ANTI-FLOW 10 GA CS CENTER DROP
C/D	63990	1	COVER, ANTI FLOW 10 GA S2 CENTER DROP
	63991	1	COVER, ANTI-FLOW 10 GA CS LEFT
	63992	1	COVER, ANTI-FLOW 10 GA S2 LEFT
31	61233	2	KEEPER, HAIRPIN LARGE CS
	63193	2	KEEPER, HAIRPIN LARGE SS

REAR VIEW SHOWN

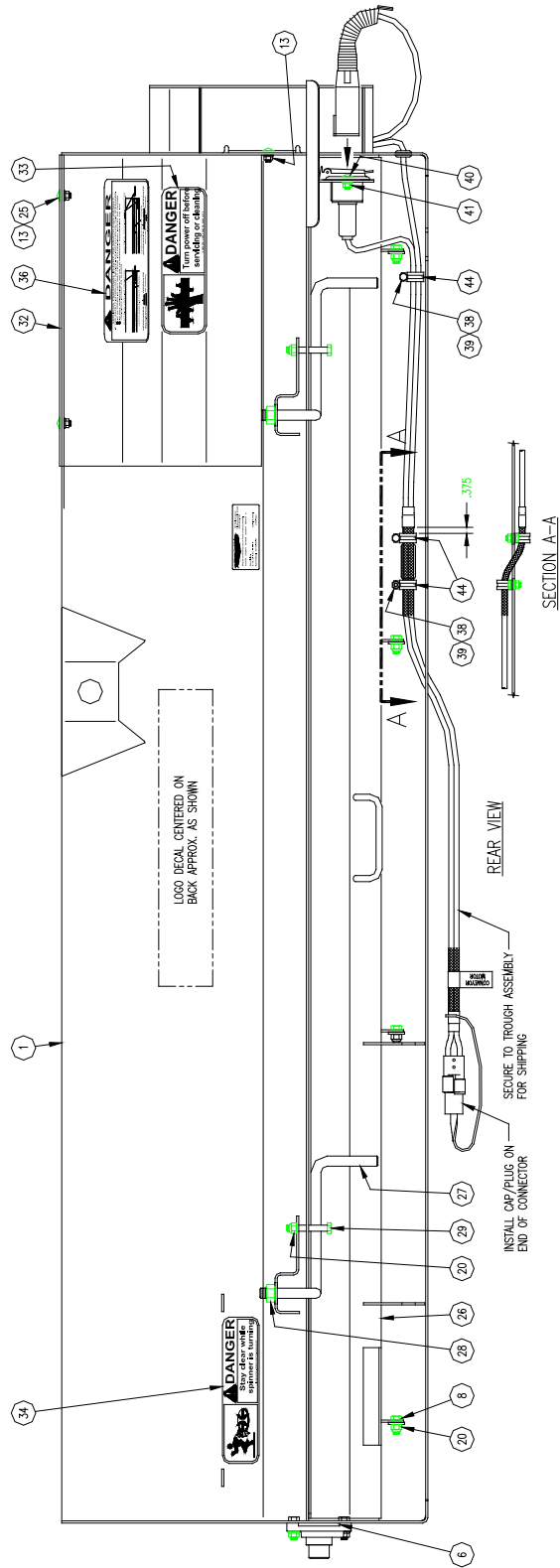

RTEL INSTALLATION AND OPERATING INSTRUCTION MANUAL

REAR VIEW PARTS LIST

ITEM	PART NUMBER	QTY.	DESCRIPTIONS
1			SEE FRONT VIEW PARTS LISTING
6	63993	5	SCREW, M8-1.25 X 20 SCH SS
8 CS	63557	4	BOLT, 3/8-16 X 1" HH ZP
SS	62696	4	BOLT, 3/8-16 X 1" HH SS
13 CS	62611	10	NUT, 3/8-16 SERRATED FLANGE ZP
SS	62743	10	NUT, 3/8-16 SERRATED FLANGE SS
20 CS	20305	6	LOCKNUT, 3/8-16 NI CS
SS	62638	6	LOCKNUT, 3/8-16 NI SS
25 CS	63994	4	BOLT, 3/8-16 X 3/4" CA G5 ZP
SS	62746	4	BOLT, 3/8-16 X 3/4" CA G5 SS
26 CS	63995	1	WELD, BOTTOM DOOR, 10 GA CS (78" SPREADER)
S2	63996	1	WELD, BOTTOM DOOR, 10 GA S2 (78" SPREADER)
CS C/D	63997	1	WELD, BOTTOM DOOR, 10 GA CS CENTER DROP (78")
S2 C/D	63998	1	WELD BOTTOM DOOR, 10 GA S2 CENTER DROP (78")
CS	63999	1	WELD, BOTTOM DOOR 10 GA CS (84" SPREADER)
S2	64000	1	WELD BOTTOM DOOR, 10 GA S2 (84" SPREADER)
CS	64001	1	WELD, BOTTOM DOOR, 10 GA CS CENTER DROP (84')
S2	64002	1	WELD, BOTTOM DOOR, 10 GA S2 CENTER DROP (84")
27 CS	64003	2	LATCH, BOTTOM DOOR, CS
SS	64004	2	LATCH, BOTTOM DOOR, SS
28 CS	63279	2	LOCKNUT, 5/8-11 TOP LOCK ZP
SS	63425	2	LOCKNUT, 5/8-11 TOP LOCK SS
29 CS	20068	2	BOLT, 3/8-16 X 2 1/2" HH G5 ZP
SS	63198	2	BOLT, 3/8-16 X 2 1/2" HH SS
32 CS	64007	1	COVER, MOTOR, 10 GA CS
S2	64008	1	COVER, MOTOR , 10 GA S2
33	62515	1	DECAL, DANGER (AUGER) (9 X 2 3/4")
34	62006	1	DECAL, DANGER (SPINNER)
36	63961	1	DECAL, SAFETY INTERLOCK ELECTRIC
38 CS	20063	6	BOLT, 1/4-20 X 3/4" HH G5 ZP
SS	62188	6	BOLT, 1/4-20 X 3/4" HH G5 SS
39 CS	62187	6	NUT, 1/4-20 SERRATED FLANGE ZP
SS	62690	6	NUT, 1/4-20 SERRATED FLANGE SS
40 CS	63304	2	BOLT, 5/16-18 X 3/4" CA G5 ZP
SS	62640	2	BOLT, 5/16-18 X 3/4" CA G5 SS
41 CS	63304	2	NUT, 5/16-18 SERRATED FLANGE ZP
SS	63310	2	NUT, 5/16-18 SERRATED FLANGE SS
44	63754	3	CLAMP, 5/8" CUSHIONED

END PLATE VIEW

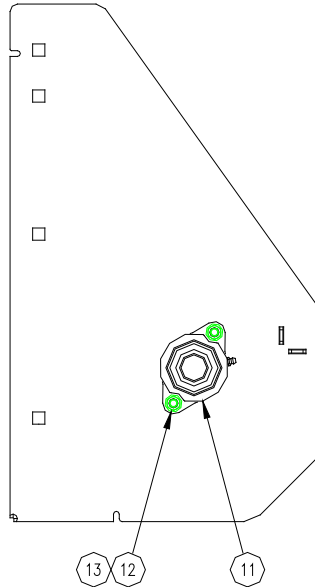

GREASE FITTING AIMS AS SHOWN;
TIGHTEN SETSCREWS

IDLER END VIEW

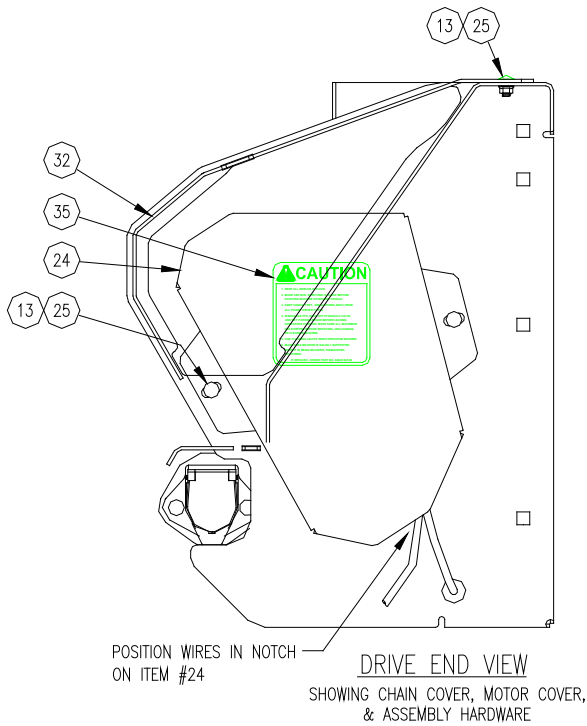

POSITION WIRES IN NOTCH
ON ITEM #24

DRIVE END VIEW

SHOWING CHAIN COVER, MOTOR COVER,
& ASSEMBLY HARDWARE

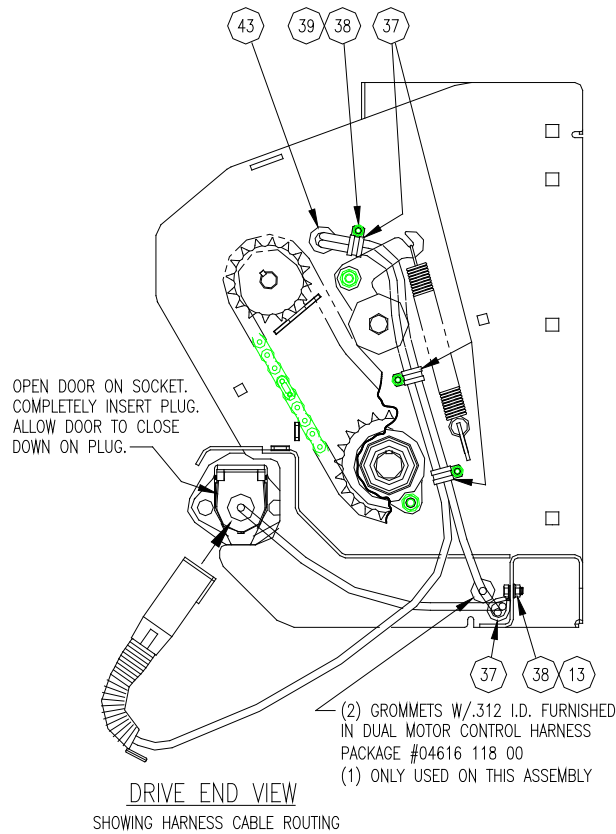

OPEN DOOR ON SOCKET.
COMPLETELY INSERT PLUG.
ALLOW DOOR TO CLOSE
DOWN ON PLUG.

(2) GROMMETS W/.312 I.D. FURNISHED
IN DUAL MOTOR CONTROL HARNESS
PACKAGE #04616 118 00
(1) ONLY USED ON THIS ASSEMBLY

DRIVE END VIEW

SHOWING HARNESS CABLE ROUTING

RTEL INSTALLATION AND OPERATING INSTRUCTION MANUAL

PARTS LIST CONT'D

ITEM	PART NUMBER	QTY	DESCRIPTION
11	61163	2	BEARING, 1 1/4"
12 CS	20066	4	BOLT, 3/8-16 Z 1 1/4" HH G5 ZP
SS	62695	4	BOLT, 3/8-16 X 1 1/4" HH SS
13 CS	62611	9	NUT, 3/8-16 SER FLANGE ZP
SS	62743	9	NUT, 3/8-16 SER FLANGE SS
24 CS	64007	1	WELD, CHAIN COVER, 10 GA CS
S2	64008	1	WELD, CHAIN COVER, 10 GA S2
25 CS	63994	3	BOLT, 3/8-16 X 3/4" CA G5 ZP
SS	62746	3	BOLT, 3/8-16 X 3/4" CA SS
32 CS	64005	1	COVER, MOTOR, 10 GA CS
S2	64006	1	COVER, MOTOR , 10 GA S2
35	62007	1	DECAL, CAUTION (4 1/4 X 4 ")
37	62652	3	CLAMP, CUSHIONED 1/2" SS
38 CS	20063	6	BOLT, 1/4-20 X 3/4" HH G5 ZP
SS	62188	6	BOLT, 1/4-20 X 3/4" HH G5 SS
43	63964	1	GROMMET, 5/8" ID

Assembled Spinner Image

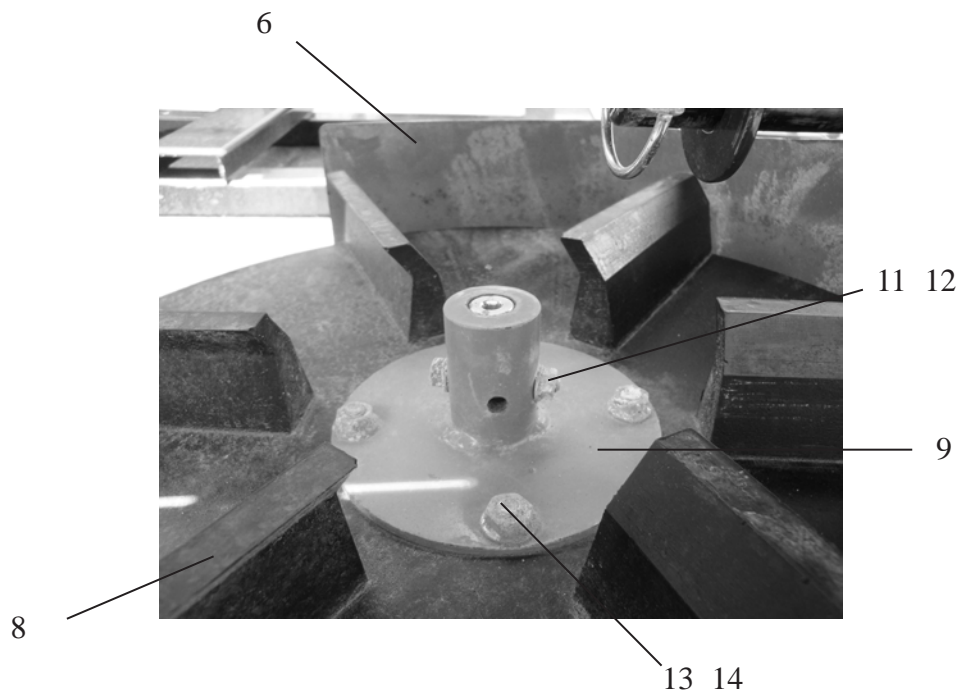
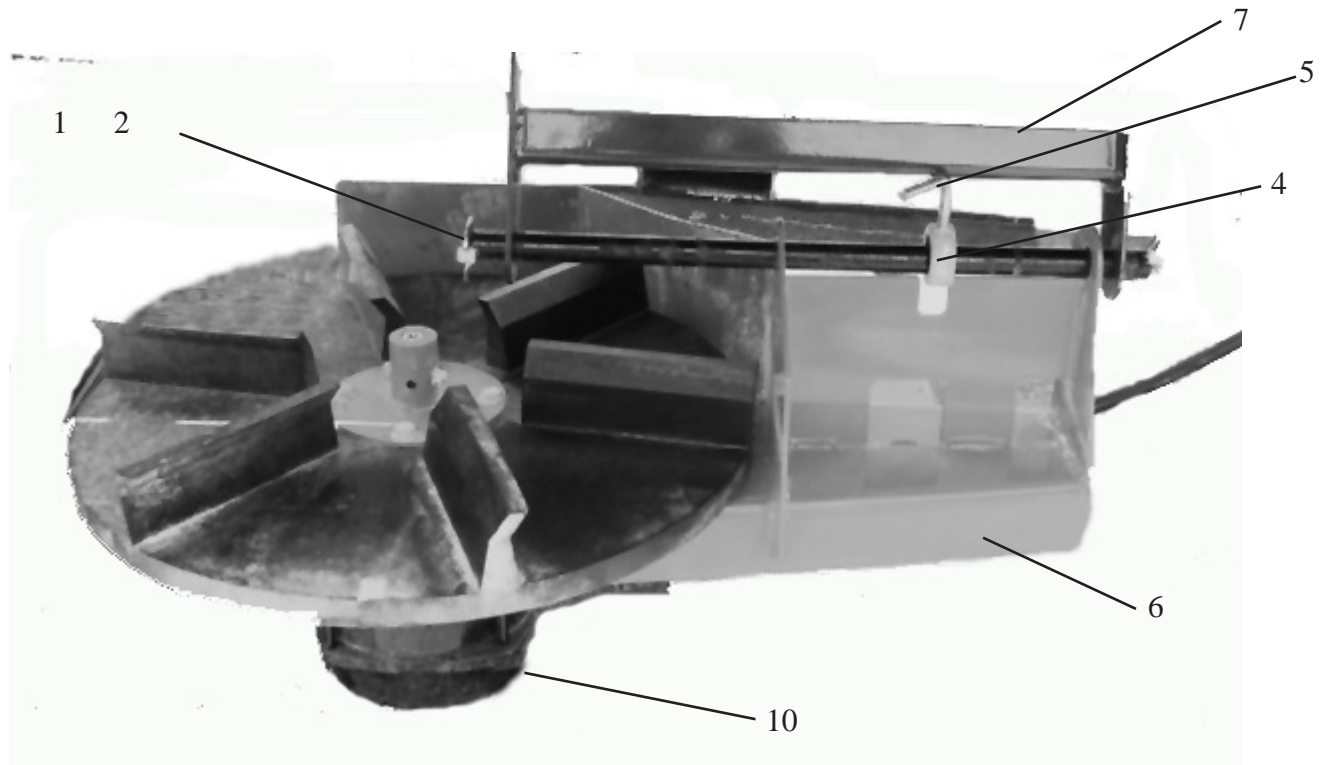

RTEL INSTALLATION AND OPERATING INSTRUCTION MANUAL

FRONT MOUNTED SPINNER CARRIAGE

ASSEMBLY PARTS LIST

ITEM	PRODUCT	QTY	DESCRIPTION
1	63271	2	ROD, HINGE, S3
2	22083	4	PIN, LYNCH
3	63447	1	ROD, CARRIAGE SUPPORT S3
4	62769	1	COLLAR, SET 1"
5	CS 64009	1	WELD, SPINNER FRAME 10G CS
	SS 64010	1	WELD, SPINNER FRAME 10G SS
6	CS 64011	1	WELD, SPINNER CARRIAGE, 10 G CS
	SS 64012	1	WELD, SPINNER CARRIAGE, 10G SS
7	64013	1	DISC, POIY 18" 1.62 BORE CCW
8	CS 64014	1	WELD, SPINNER HUB CS
9	64015	1	MOTOR, 12 V 1650 rpm 60 A 1/2 HP
10	63193	1	KEEPER, HAIRPIN LARGE, SS
11	62695	4	BOLT, 3/8-16 X 1 1/4" HH SS
12	22230	4	FLAT WASHER, 3/8" U.S.S. SS
13	62743	4	NUT, 3/8-16 SER FLANGE SS
14	63268	4	BOLT 5/16-18 X 1/1/4" HH SS
15	63173	5	FLAT WASHER 5/16 U.S.S. SS
16	63310	5	NUT 5/16-18 SER FLANGE SS
17	64016	1	BOLT, M6-1.0 X 40 mm HH SS
18	64017	1	LOCKNUT, M6-1.0 TOP LOCK SS
19	62459	1	LOCK, SPINNER, S3
NS	62773	1	BOLT 5/16-18 1 1/2" HH SS

SEL INSTALLATION AND OPERATING INSTRUCTION MANUAL

NAME PLATE INFORMATION

EXPLANATION OF SERIAL NUMBER DECAL

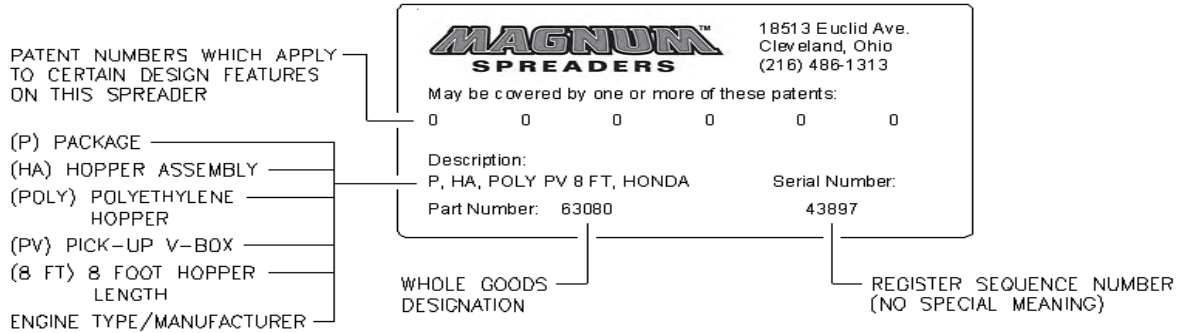

TWO YEAR WARRANTY

TWO YEAR WARRANTY

Magnum Spreader promises to the consumer to repair, or at our option to replace any part of this Magnum Spreader, accessory (other than noted below) except expendable parts such as pins, Spreader fins, and other normal wear items, which proves to be defective in workmanship or material under normal use for a period of two year's from the date of delivery to the original purchaser. During the two year's, Magnum Spreader will provide, through its Distributor / Sub-Distributor network, all labor or parts necessary to correct such defects free of charge. Faulty parts will be repaired or replaced by the Distributor / Sub-Distributor where that particular piece of equipment was purchased. Any cost incurred in returning the product to the Distributor / Sub-Distributor is the responsibility of the consumer.

EXCLUSIONS

IN NO EVENT SHALL MAGNUM SPREADER BE LIABLE FOR SPECIAL, INCIDENTAL OR CONSEQUENTIAL DAMAGES OR FOR DAMAGES RESULTING FROM LACK OF NECESSARY MAINTENANCE, FROM MISUSE, ABUSE, ACTS OF GOD, ALTERATION OF ANY PRODUCT, OR FROM USE OF PARTS NOT SUPPLIED BY MAGNUM SPREADER. USE OF THE MAGNUM SPREADER FOR ANY PURPOSE OTHER THAN SPREADING MATERIALS AS INTENDED BY MAGNUM SPREADER, IS ONE EXAMPLE OF AN ABUSE AND MISUSE OF THE PRODUCT.

WARRANTY SERVICE

In order to obtain service under this warranty, the consumer must return this product to the Distributor / Sub-Distributor from whom the product was purchased or to any authorized Magnum Spreader Distributor / Sub-Distributor, transportation and freight charges prepaid. Only Magnum Spreader Distributors / Sub-Distributors are authorized to perform the obligations under these warranties. For the address and telephone number of the Distributor / Sub-Distributor nearest you, check the telephone directory or you may write to the warrantor at the address below.

GENERAL

It is the responsibility of the consumer to establish the warranty period by verifying the original delivery date. A bill of sale, canceled check or some other appropriate payment record may be kept for that purpose. For this warranty to be effective, the consumer must Register the product on-line at www.magnumspreaders.com. No person is authorized to change this warranty or to create any warranty other than that set forth herein. This warranty gives you specific legal rights and you may also have other rights which vary from state to state.

In order to validate this warranty, please go to our web site www.magnumspreaders.com to register your new Magnum Spreader.

Magnum Spreader reserves the right, under its continuing product improvement program, to change construction or design details, specifications and prices without notice or without incurring any obligation.

Magnum Spreader
18513 Euclid Ave. * Cleveland, Ohio 44112-1084
Phone 486-1313 (Area Code 216)
www.magnumspreaders.com

© 2007 Printed in the U.S.A.



MAGNUM SPREADERS
18513 EUCLID AVE.
CLEVELAND, OHIO 44112-1084

PHONE: (216)486-1313

website: www.magnumspreaders.com

**IMPORTANT
INFORMATION
ENCLOSED**

