

# Owner's Manual

This Manual Must Be Read Before Operating The Equipment

# SNOWEX<sup>®</sup>

LEADERS IN ICE CONTROL

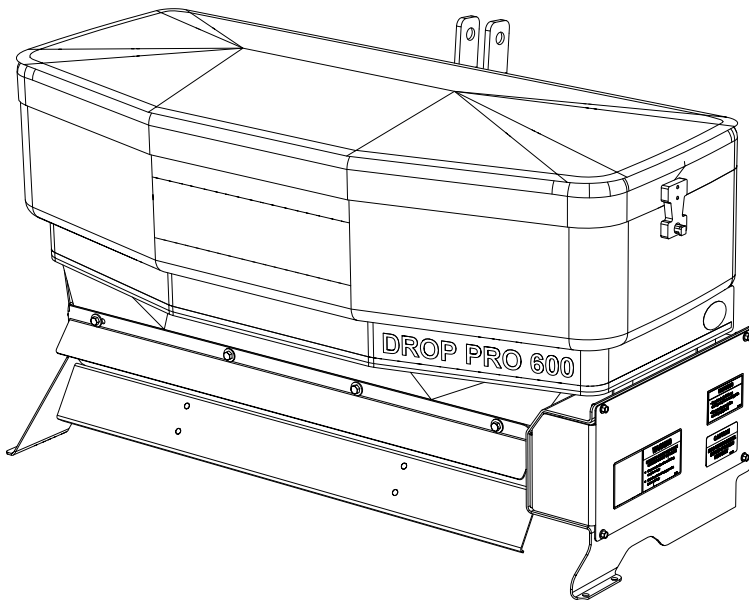

## SD-600

Serial No. X2-100038 and higher

## SD-1400

Serial No. X3-100019 and higher



**CUSTOMER COPY**

Madison Heights, Michigan 48071  
800-SALTERS  
www.snowexproducts.com



# Table of Contents

Introduction ..... 3

Safety ..... 4

Operating Instructions.....5-6

    Loading Spreader ..... 5

    Operating the Controller ..... 5

    Attaching to Vehicle ..... 6

    Adjustable Material Baffles ..... 6

Maintenance Instructions ..... 7

    Cleaning ..... 7

    Corrosion Prevention ..... 7

    Storage ..... 7

Troubleshooting ..... 8

Notes ..... 9-11

Have a question or need assistance?

**SnowEx Customer Care**

**(800) SALTERS**

or (248) 586-3500

Monday through Friday 8:00 AM to 4:30 PM EST

Fax: (248) 691-8378

E-mail: [customercare@trynexfactory.com](mailto:customercare@trynexfactory.com)

Website: [www.snowexproducts.com](http://www.snowexproducts.com)

# Introduction

This manual is intended to help you to get to know your Drop Pro Spreader and how to operate it safely, correctly and economically. If you observe these instructions, you will prevent hazards, reduce repair costs and breakdown times, and increase the reliability and service life of the machine.

The manual must be read and used by every person who will be working with or on the machine for:

- Operation (including preparation, repair during operation, & clean-up)
- Repairs (maintenance, inspection, overhaul), and/or
- Transport.

All regulations for safety and proper working practice must be observed in addition to this manual and any applicable regulations for the prevention of accidents. Should you lose your Owner's Manual or would like extra copies, they can be purchased from your SnowEx dealer.



### THIS SIGN SHOULD ALERT YOU:

This Safety Alert Symbol is used to pinpoint characteristics that, if not carefully followed, can create a safety hazard. When you see this symbol in this manual or on the machine itself, be alert! Your personal safety and the safety of others is involved.

Defined below are the Safety Alert Messages.



## DANGER

### DANGER

Information that, if not carefully followed, can cause death.



## WARNING

### WARNING

Information that, if not carefully followed, can cause serious personal injury or death.



## CAUTION

### CAUTION

Information that, if not carefully followed, can cause minor injury or damage to equipment.



### IMPORTANT

This symbol is used to call out information that is important to follow carefully.

### IMPORTANT EQUIPMENT INFORMATION

Record important machine information here for quick reference. This information can be found on the Serial Number Plate located on the Motor Enclosure; the Serial Number Label on the Control Pendant; and the Serial Number Label on the Control Module.

Model \_\_\_\_\_

Spreader Serial # \_\_\_\_\_

Control Module Serial # \_\_\_\_\_

Control Pendant Serial # \_\_\_\_\_

Date Purchased \_\_\_\_\_

Dealer where purchased \_\_\_\_\_

*Example*

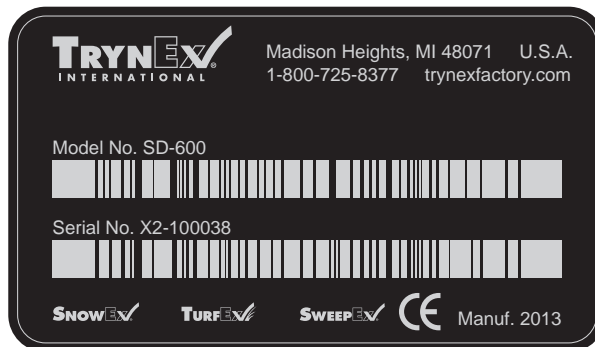

Model # F51038  
 Serial # 1234  
 TRYNEX INTERNATIONAL  
 1-800-725-8377

Before attempting any procedure in this book, the safety information in this manual must be read and understood by all personnel who have any part in the installation, preparation, transport, service, repair or use of this equipment.

For your protection, safety and information decals have been placed on the spreader to remind the operator of safety precautions and particular hazards.

## **DANGER**

Never exceed the Gross Vehicle Weight Rating (GVWR). Overloading will result in unpredictable and unsafe vehicle handling.

Never attempt to remove the spreader from a vehicle with material in it.

Always have someone to help you remove or install spreader. Use lifting devices such as a forklift or crane where possible to prevent injury to yourself and others, and damage to the equipment.

Never operate equipment when under the influence of alcohol, drugs, or medications. These substances alter your judgement and slow your reactions.

Always keep hands, feet, clothing, jewelry, and hair away from moving parts. These items will catch and be pulled in by moving parts, causing serious personal injury.

Always shut off vehicle before attempting to attach, detach, or service the spreader. Be sure vehicle is properly braked, chocked, and on level ground.

Use caution when driving and drive at a sensible speed, where braking distances are safe and safe handling characteristics are maintained.

## **WARNING**

Before working with the spreader, secure all loose clothing and hair. Clothing and hair could get caught in moving parts.

Always wear safety glasses with side protection when servicing spreader or near where salt/ice melter is being spread.

Never allow children to operate equipment or play on or around equipment.

Always make sure people are clear of where you will be using equipment. Always check areas to be spread to ensure no hazardous conditions or substances are in the area.

Inspect the spreader before and after operating for defects. Parts that are broken, missing or worn out must be replaced before operating.

Do not modify the spreader without written permission from SnowEx. Modifying the spreader or its mount can affect performance and safety.

## **CAUTION**

Remember most accidents are preventable and caused by human error. Exercise care and observe precautions to prevent injury to yourself and others.

Never use wet materials or materials with foreign debris with the spreader. The spreader is designed to spread dry, clean, free-flowing material.

Never leave material in hopper between storms, or when storing. Ice melters are hygroscopic and will attract moisture and harden up.

Empty the spreader and clean it after each use to prevent ice melter from building up and covering metal parts, causing corrosion.

# Operating Instructions

## Loading Spreader/Operating the Controller

### LOADING SPREADER

Do not overload vehicle. Use the chart below to calculate the weight of spreader and material to comply with Vehicle Weight Ratings.

Empty weight of spreaders:

SD-600	175 lbs.
SD-1400	375 lbs.

Approximate capacity of spreaders:

SD-600	6 cubic feet
SD-1400	14 cubic feet

Approximate weight of full spreaders:

With Rock Salt	
SD-600	685 lbs.
SD-1400	1565 lbs.

With Calcium Chloride Pellets	
SD-600	655 lbs.
SD-1400	1495 lbs.

MATERIAL WEIGHTS	
MATERIAL	WEIGHT PER CUBIC FT.
Rock Salt	80-90 lbs.
Calcium Chloride Pellets	75-85 lbs.

Leave the screen in the hopper when loading to prevent chunks and foreign objects from entering the hopper and damaging the spreader.

### OPERATING THE CONTROLLER



**BLAST**  
Turns spreading mechanism to full speed momentarily.

**VIBRATE**  
Turns Vibrator on/off. Improves flow and prevents “bridging.”

**ON/OFF**  
Turns Spreader and Control on/off.  
**START/STOP**  
Turns spreading mechanism on/off.

Use the On/Off button to turn the spreader off between jobs. The Start/Stop pauses spreading, but the vibrator will stay on. Use Start/Stop for when you need to pause spreading for a short time. Use Blast to momentarily increase the application rate – the spreader will operate at full speed until the button is released.

## Operating Instructions

### Attaching to Vehicle/Adjustable Material Baffles

#### ATTACHING TO VEHICLE

If you are using a TPR-020 insert the hitch into your receiver. Lock with Hitch Pin and Hair Pin. Plug Spreader Harness into Vehicle Harness and you are ready to begin spreading.

If you are using the UBM-175 mount, follow the UBM-175 Installation Instructions, Connect the Spreader Harness to the Vehicle Harness and you are ready to begin spreading.

To attach to your tractor's three-point hitch, simply back up to the spreader frame (requires F51196 on SD-600) and attach the hitch to the spreader. Plug in and begin spreading.

#### ADJUSTABLE MATERIAL Baffles

The Drop Pro is equipped with adjustable material baffles inside the hopper. These baffles restrict the flow of salt to the Distribution Shaft. Leave these baffles at the factory setting until you have run some material through the spreader at different speeds. The Baffles may need adjusted for different materials, or if the Distribution Shaft is getting too much material, due to an easily flowing material.

Use an 1/2" wrench for the bolts.

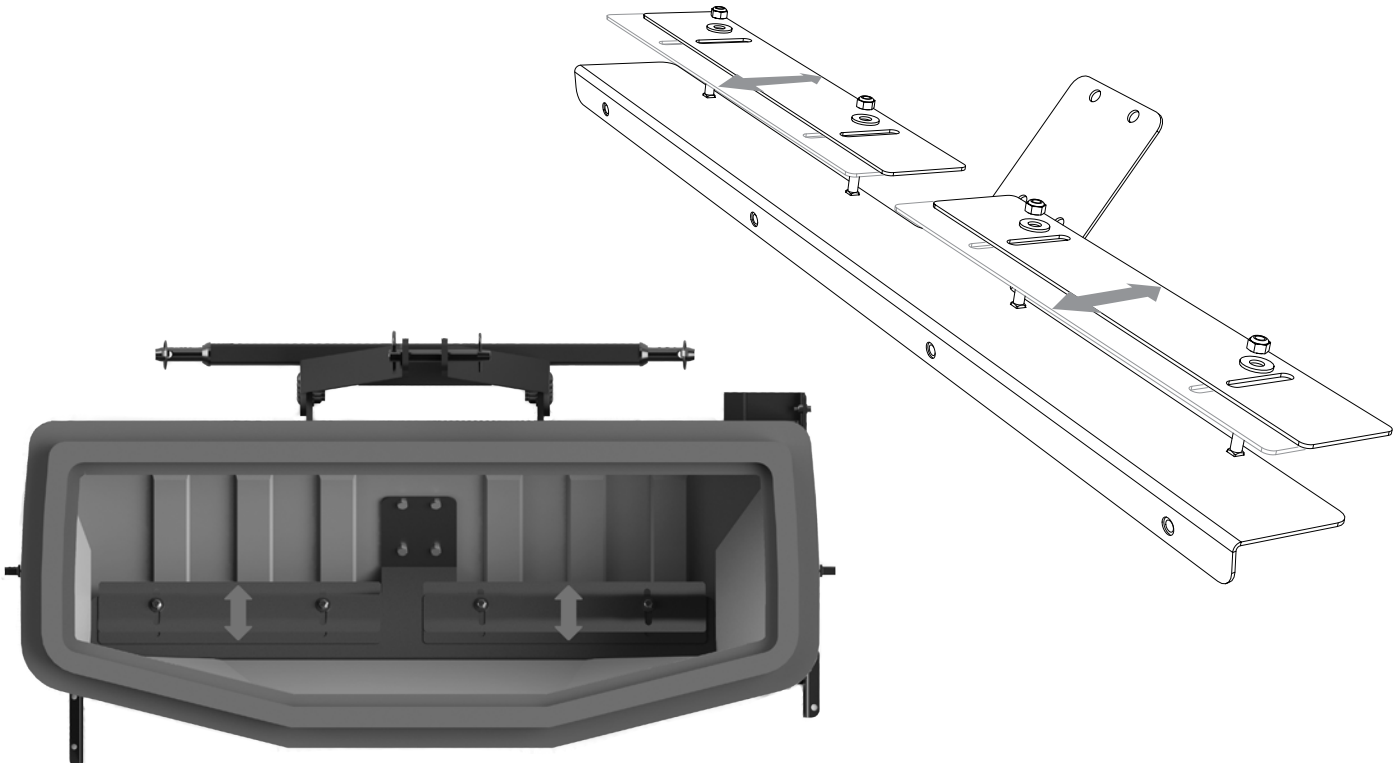

## Maintenance Instructions

### Cleaning/Corrosion Prevention/Storage

---

#### **CLEANING**

To protect your Drop Pro from corrosion and to increase its useful life, clean it after each storm. By cleaning after each storm, salt build-up will be less and the salt will be easier to remove.

After each snow storm:

Run the spreader to empty the hopper.

Turn the spreader control off and unplug the spreader before cleaning. Use water to rinse all of the salt residue away. Pay special attention to tight areas, enclosures and hard-to reach areas where salt build-up is likely to be a problem. Rinse these areas thoroughly. Avoid directly rinsing openings in transmissions/motors, such as where a shaft might come out of the housing. Use a car wash brush to clean salt and grime that is stuck. Consider using a salt-removal product or spraying your spreader with a cleaning solution before rinsing. Rinse all cleaning solutions off thoroughly with water.

Make sure there are no puddles of water on the surface of the spreader and remove water from the bottom of the hopper so the Distribution Shaft isn't frozen when you use your spreader again.

Grease bearings, put dielectric grease on plugs, spray metal parts with a light oil. Avoid getting oil on the plastic – this will cause the plastic to degrade.

---

#### **CORROSION PREVENTION**

Corrosion/Rusting is a chemical reaction caused by presence of moisture, salt, and metal. Preventing any one of these ingredients from coming in contact with any other ingredient will prevent corrosion.

Storing the spreader indoors, cleaning the spreader after each use, lubricating bearings, and spraying oil on the metal will limit corrosion. Use a water displacing oil in tight areas, especially where parts butt against each other.

Light oil applied to metal parts will prevent salt and grime from getting stuck to the frame (making it easier to clean) and will prevent scratched or chipped areas from rusting.

---

#### **STORAGE**

How you store your spreader can have a lot to do with how long it lasts and how well it performs. Store your spreader in a sheltered area, preferably indoors. If it must be stored outside, elevate it on wooden blocks and cover with a tarp; secure the tarp so it won't blow away in the wind. Before putting your spreader away, perform a very thorough cleaning, lubricate bearings, and spray oil on metal parts. Apply a protective plastic conditioner to the hopper and lid to protect them from the elements. Put Dielectric Grease on all plugs and connections prior to storage.

Material Flow		
Fault	Possible Cause	Remedy
Too much material	Spreading Speed too high	Decrease Speed
	Vibrator is on	Turn Vibrator off – Use intermittently
	Adjustable Baffles open too much	Adjust Baffles
Not enough material	Material is very fine	Adjust Baffles
	Spreading Speed too low	Increase Speed
	Material is bridged in hopper	Use Vibrator
No Material is Spreading	Material Baffles closed too much	Adjust Baffles
	Control is off	Turn Control on
	Material is bridged	Turn Vibrator on
	Foreign object in Hopper	Remove Object
	Hopper is Empty	Fill Hopper
	No Power to Motor	Check connections
		Put Dielectric Grease on all Connections
		Check Harnesses for damage
		Contact your dealer
Controller		
Fault	Possible Cause	Remedy
OL	Jammed Material	Clear jam/blockage
	Auger Over-Full	Turn off vibrator (if on)
		Adjust Baffles to restrict flow
	Foreign Object in Hopper	Remove Object
E0	Frozen/Hardened Material	Shovel it out
	Spreader Harness Unplugged	Re-Connect/Dielectric Grease
	Motor Unplugged	Re-Connect/Dielectric Grease
LB	Cut in harness	Check all harness, replace affected harness(es)
	Corroded Connection	Clean/Dielectric Grease
		Replace Connectors
	Loose Connection	Tighten/Dielectric Grease
		Replace
E1	Low Battery (less than 12 volts)	Charge Battery
		Test Battery, Replace if bad
		Test Alternator, Replace if bad
	Wires Crossed	Check Harnesses for bare wires
		Check for loose wires/connections
On/Off Switch Lights, No Display	Controller not connected	Check connections at Control Module
No Display, On/Off Switch does not light up	No Power to Controller	Check for Cuts in Battery Harness
		Test Controller (Contact Dealer)









