

**SEL SERIES ELECTRIC  
TAILGATE SPREADER**



**MAGNUM<sup>TM</sup>**  
**SPREADERS**

## INCLUDED IN THIS MANUAL:

|  |       |
|--|-------|
| Safety Instructions -----                            | 3-5   |
| Control Electric Specifications & Installation ----- | 6     |
| Harness and Wiring Diagram -----                     | 7-9   |
| Trough mounting instructions-----                    | 10-11 |
| Spinner Assembly and Installation -----              | 12-14 |
| Spinner Spread Pattern Instructions -----            | 15-16 |
| Operating Instructions -----                         | 17-18 |
| Recommended Regular Maintenance -----                | 19    |
| Assembly Parts Drawing & Parts List -----            | 21-28 |
| Spinner Assembly Parts Drawing & Parts List -----    | 29-32 |
| Name Plate Information -----                         | 33    |
| Warranty -----                                       | 34    |

# SEL INSTALLATION AND OPERATING INSTRUCTION MANUAL

## SAFETY PRECAUTIONS

The best safety device is a careful operator!



This symbol means **ATTENTION!**

**Become Alert!**

**Your safety is involved!**

**Please read and understand completely before doing!**

**BEFORE PERFORMING MAINTENANCE OPERATIONS, PARK VEHICLE ON LEVEL GROUND. SET PARKING BRAKE, SHUT OFF ALL POWER, AND MAKE SURE ALL MOVEMENT HAS STOPPED. IF BODY IS RAISED, IT MUST BE SECURELY BLOCKED SO IT CANNOT COME DOWN. SUPPORT BLOCKS MUST NOT BE REMOVED UNTIL THERE IS NO DANGER OF ANYONE BEING UNDER BODY WHEN BODY IS LOWERED.**



**Improper use of this equipment can result in serious injury. To reduce this possibility, give complete and undivided attention to the job at hand, and follow these safety precautions.**

### PREPERATION:

Know your controls. Read this instruction manual. Learn how to stop the equipment quickly in an emergency.

Do not allow children to operate machine; nor adults to operate it without proper instructions.

Keep all individuals not involved in the use of the equipment a safe distance away.

A copy of this manual should be available in the cab at all times. A copy may be obtained from your local dealer or download from [www.magnumspreaders.com](http://www.magnumspreaders.com)

### OPERATION:

Do not exceed rated capacities of chassis or hoist.

Observe and shut off all equipment controls before starting engine so equipment will not unintentionally operate when engine is started.

Always check area around machine before engaging or operating controls.

Vehicle should be on a flat surface prior to raising bed. Operation on slippery uneven terrain may result in equipment damage or personal injury.

Know the material you are hauling and plan your haul to avoid "set up" or freezing of the load in the dump body. In the event that a load becomes stuck or frozen in the body, do not abuse, overload, or damage the truck, hoist, or body in efforts to quickly free the load. It may be necessary to thaw indoors to safely remove such a load.

In the event that shoveling or mechanical means are used to free the stuck load, be sure the load is NOT hoisted and the tailgate, if opened, is secured properly before starting this effort. If hoisted, a stuck load, or portion, could release unexpectedly and cause injury to personnel or damage to the body, truck, or surroundings.

Some materials such as mud, or sludge, may shift easily when wet, resulting in increased tendency to overturn the truck on curves, unstable ground, or side slope situations. Reduce load size, speeds, and side slopes, and use care and planning to avoid this potential occurrence.

Unload the body and securely prop and block a raised body before any service, inspection, or repair work is started.

Be sure the PTO is disengaged before traveling. Failure to disengage the PTO from driving the pump/valve when in transit may allow the dump body to rise unintentionally. This may lead to loss of vehicle control, accidental injury and/or property damage.

Lift points are provided to safely lift body assembly. Never lift or handle loaded body, empty material prior to handling the body.

Always wear relatively tight and belted clothing when operating equipment. Loose jackets, shirts sleeves or other loose clothing should not be worn because of the danger of catching them in moving parts or controls.

Stop and inspect equipment if unusual movement, sounds, or noises are observed. Repair damage before restarting and operating the equipment.

Disengage power to all operating equipment: (1) before leaving operator's position, (2) before making any repairs or adjustments, or (3) when not in use.

Take all possible precautions when leaving the equipment unattended; such as disengaging the hydraulic system, shifting vehicle out of gear, setting parking brake, shutting off engine and removing key. Never leave raised body unattended.

## NOTICE!

Your spreader is equipped with a safety interlock device. This device must be disconnected before the spreader trough bottom door and the spreader trough top cover can be opened exposing the auger. This device positively disconnects all electric power from the auger drive motor to prevent accidental bodily injury due to contact with a turning auger.



This decal appears on the left end, or the right end of the spreader trough. It cautions all to observe general safety procedures when operating this equipment.

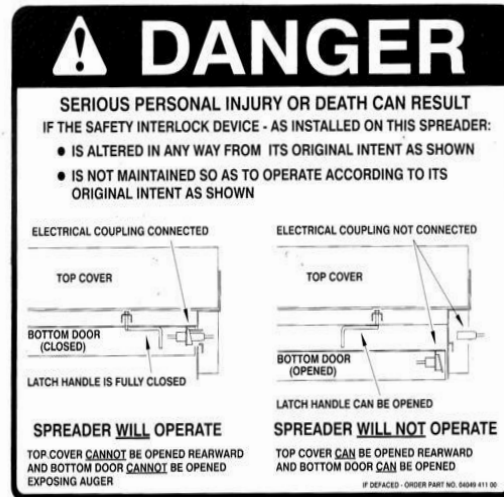

This decal appears on the back of the spreader cover plate at the right end of the spreader. It alerts all to the danger associated with the improper use of the Safety Interlock Device.



This decal appears on the back of the spreader trough cover plate. It alerts all to the danger of being caught in the dropout opening or from the top of the spreader trough where serious personal injury could result.



This decal appears near the spinner assembly on the back of the spreader trough cover plate. It alerts all to the danger of being struck by material being spread by the spinner assembly which could result in serious personal injury.

# SEL INSTALLATION AND OPERATING INSTRUCTION MANUAL

## SAFETY DECAL LOCATIONS

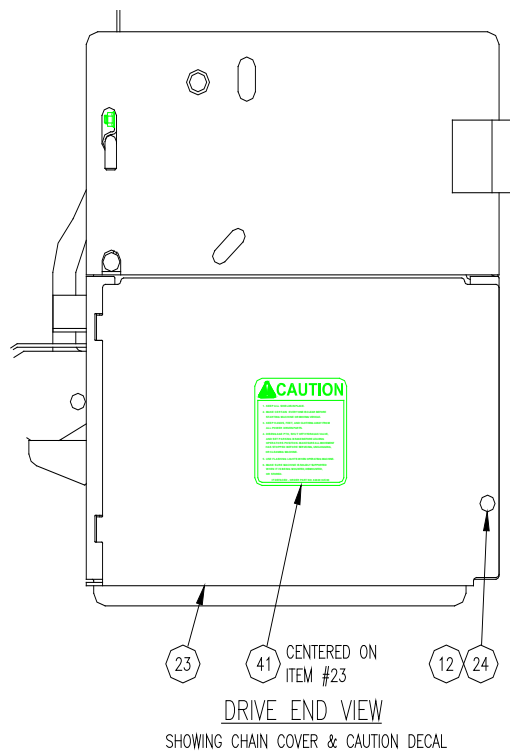
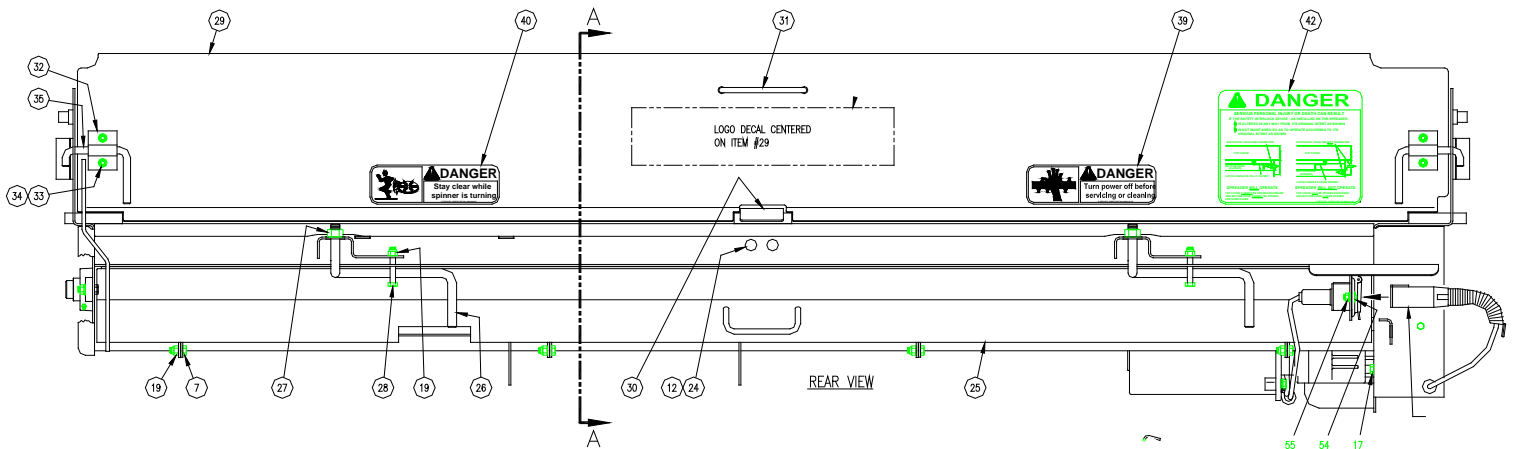

| ITEM | PRODUCT | QTY | DESCRIPTION                          |
|------|---------|-----|--------------------------------------|
| 39   | 62515   | 1   | DECAL, DANGER (AUGER) (9 X 2 3/4")   |
| 40   | 62006   | 1   | DECAL, DANGER (SPINNER) (9 X 2 3/4") |
| 41   | 62007   | 1   | DECAL, CAUTION (4 1/4 X 4 ")         |
| 42   | 64055   | 1   | DECAL, SAFETY INTERLOCK ELEC.        |

## ELECTRIC CONTROL SPECIFICATIONS AND INSTALLATION ELECTRIC CONTROL PANEL 63962 W/ SYSTEM SPECIFICATIONS

**SPECIFICATIONS:**

- UNIT TYPE.....DUAL VARIABLE SPEED CONTROLLER
- OPERATING VOLTAGE.....12V DC
- DUTY.....CONTINUOUS ALL SETTINGS
- CAPABILITY.....EACH CIRCUIT TO CONTROL 1/2 HP (MINIMUM) DC MOTOR
- INITIAL STARTUP.....GO STRAIGHT TO "BLAST" MODE FOR SEVERAL SECONDS;  
RETURN TO EXISTING DIAL SETTINGS
- OVERLOAD PROTECTION.....80 AMPS (FOR EITHER CIRCUIT, OR TOTAL)
- CONTROLS.....KNOB STYLE DIALS & ROCKER SWITCHES

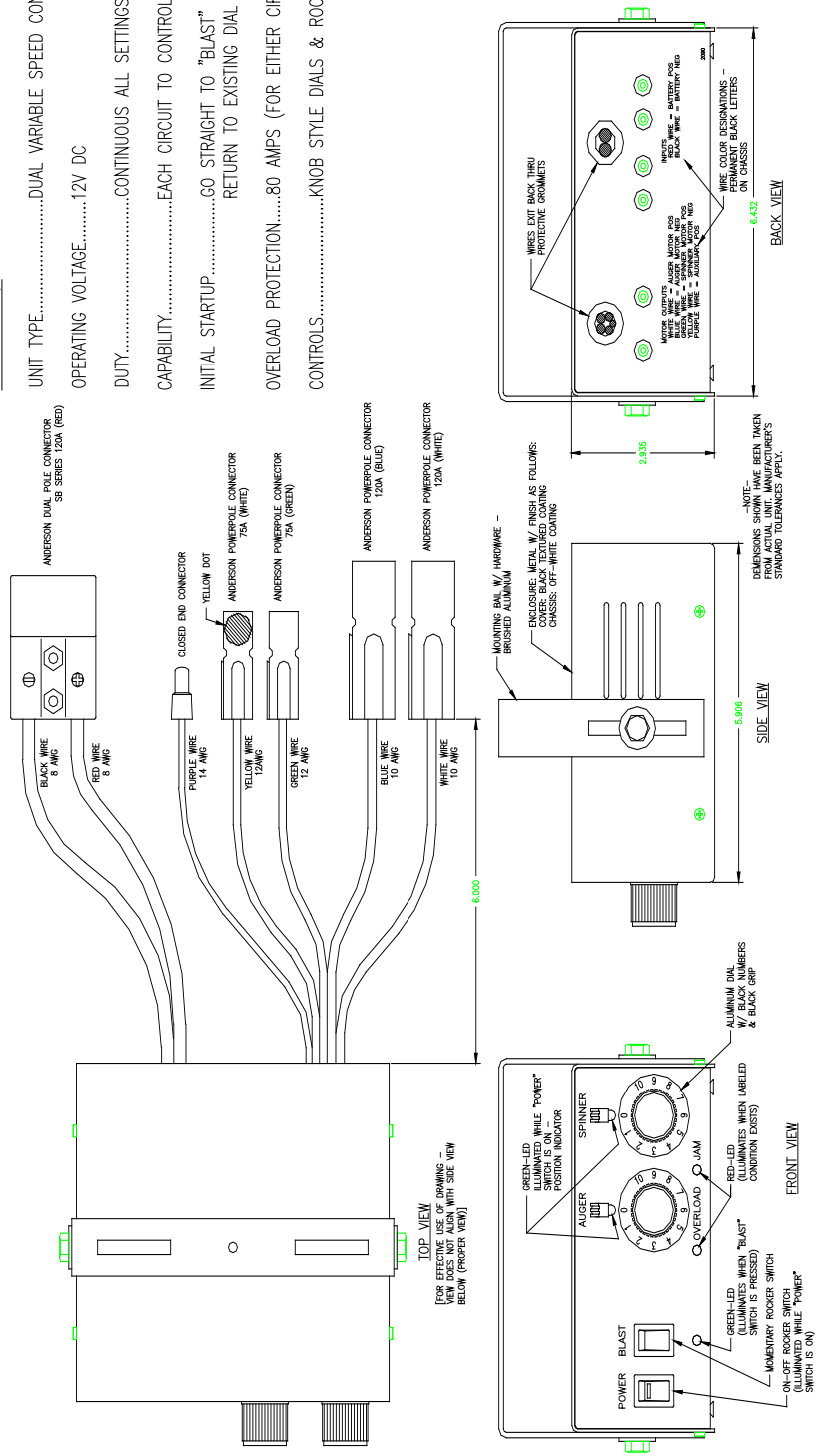

# SEL INSTALLATION AND OPERATING INSTRUCTION MANUAL

## ELECTRIC CONTROL INSTALLATION (Continued)

### ELECTRIC WIRING HARNESS

63963

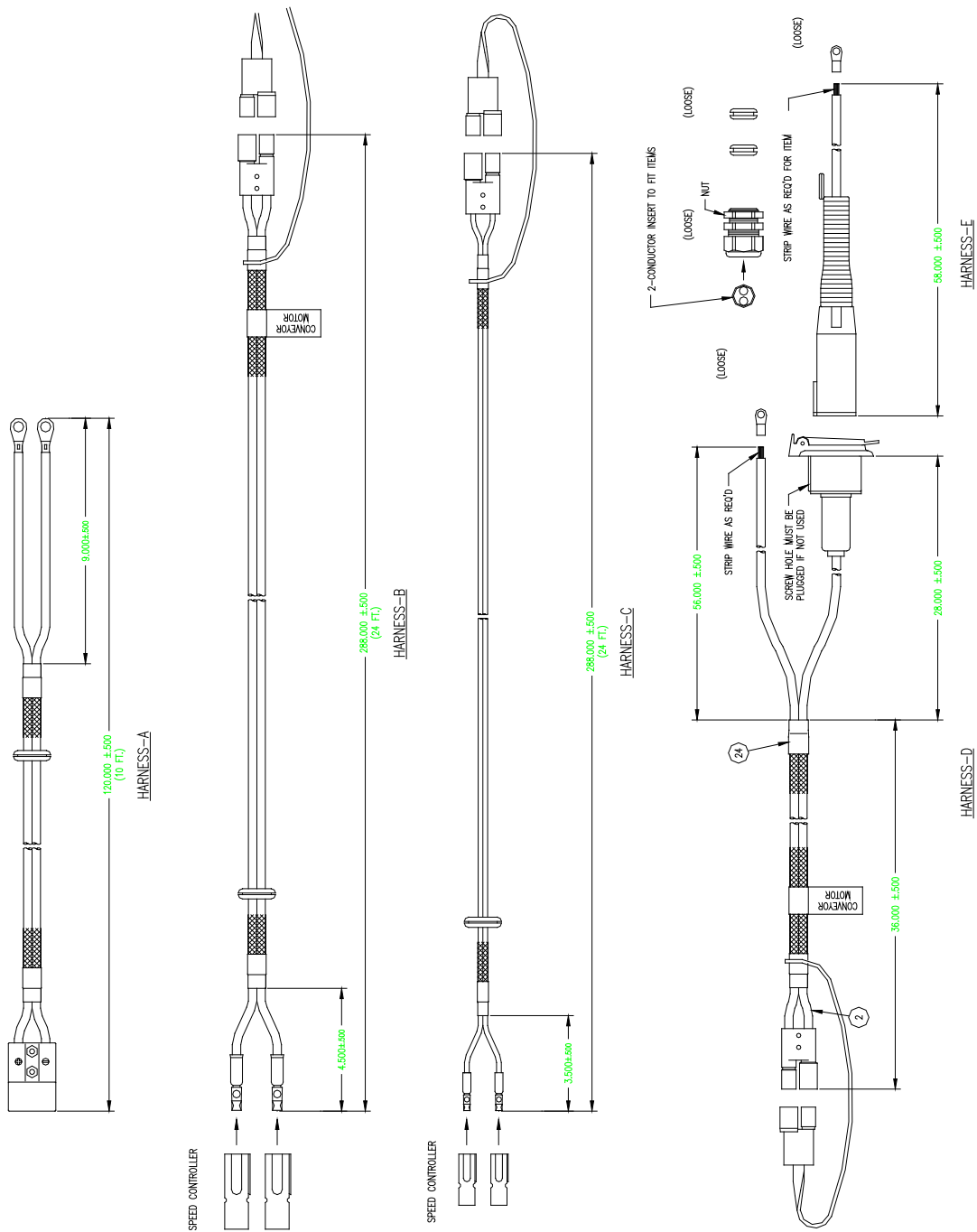

**DRIVE END VIEW**  
**WIRING HARNESS ROUTING**  
**64019 (CS TROUGH ASSY)**  
**64020 (SS TROUGH ASSY)**  
**64021 (CS CD TROUGH ASSY)**  
**64022 (SS CD TROUGH ASSY)**

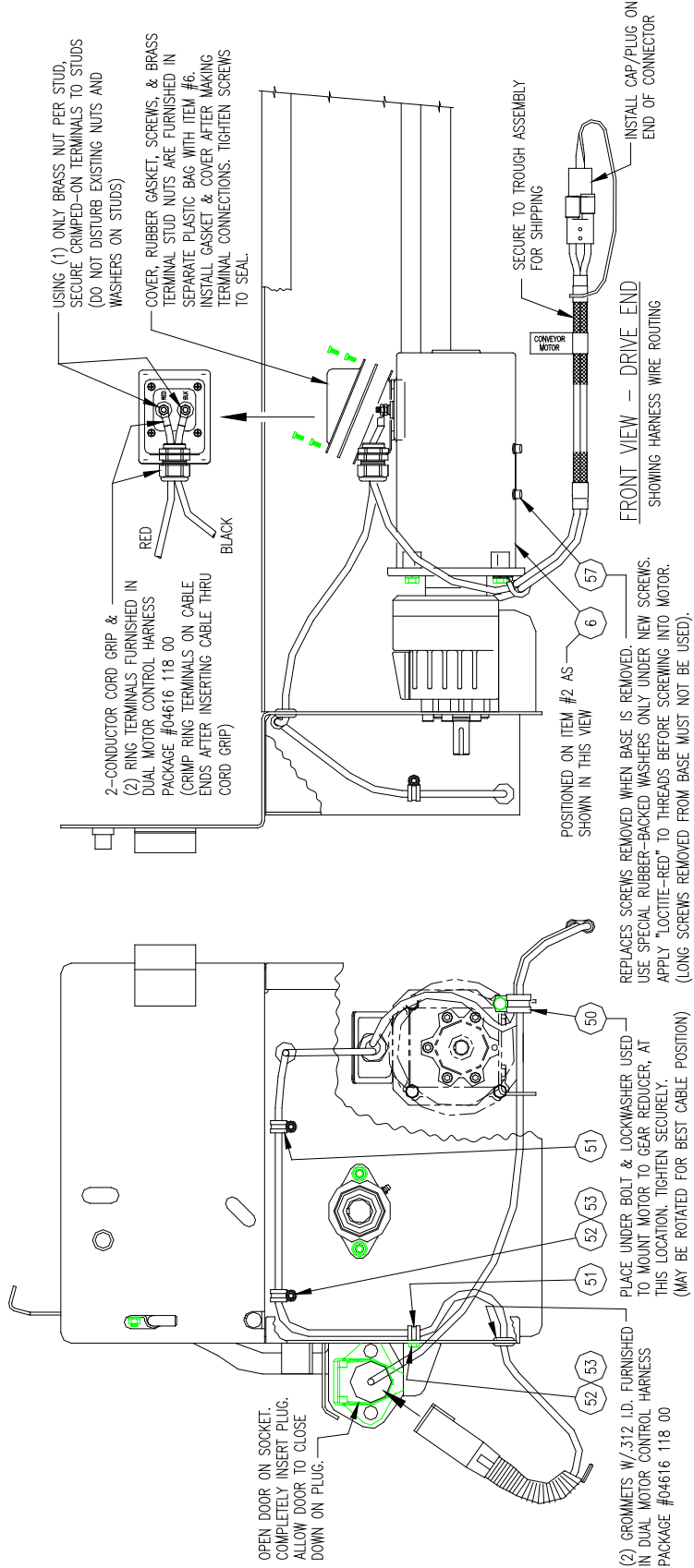

# SEL INSTALLATION AND OPERATING INSTRUCTION MANUAL

## PARTS LIST CONT'D

**64019 (CS TROUGH ASSY)**

**64020 (SS TROUGH ASSY)**

**64021 (CS CD TROUGH ASSY)**

**64022 (SS CD TROUGH ASSY)**

| ITEM  | PRODUCT | QTY | DESCRIPTION                     |
|-------|---------|-----|---------------------------------|
| 6     | 64015   | 1   | MOTOR, 12 V 1650RPM 60A 1/2 HP  |
| 50    | 64023   | 1   | CLAMP, CUSHIONED 3/4" WIDE 1/2" |
| 51    | 63245   | 3   | CLAMP, CUSHIONED 3/8" LOOP SS   |
| 52 CS | 20003   | 3   | BOLT, 1/4-20 X 3/4" HH G5 ZP    |
| SS    | 62189   | 3   | BOLT, 1/4-20 X 3/4" HH SS       |
| 53 CS | 62187   | 3   | NUT, 5/16-18 SER FLANGE ZP      |
| SS    | 62690   | 3   | NUT, 5/16-18 SER FLANGE SS      |
| 57    | 64024   | 4   | SCREW, M6--1.0 X 10 SCH SS      |

# NOTES

TROUGH MOUNTING INSTRUCTIONS

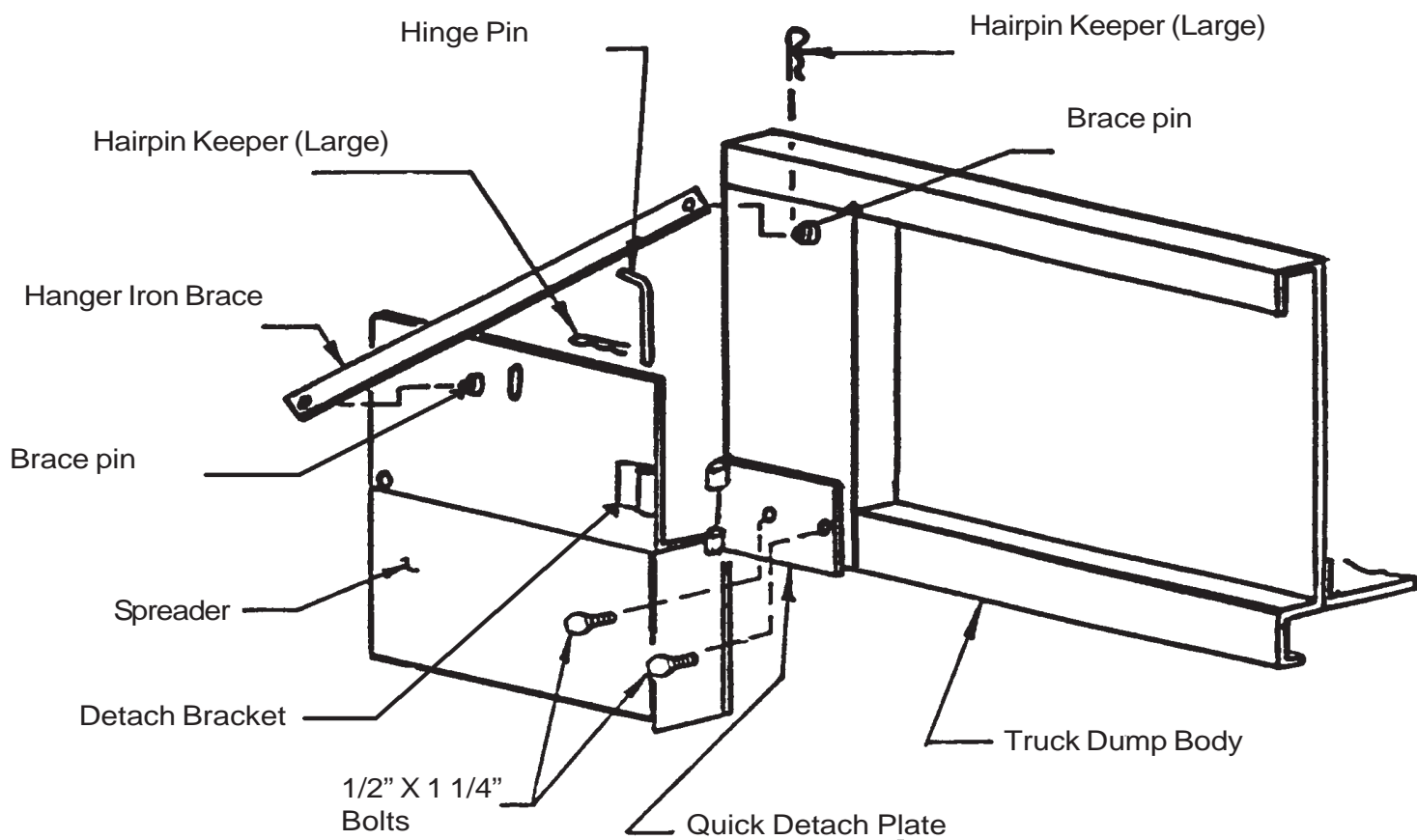

## TROUGH MOUNTING INSTRUCTIONS

(Continued)

### GENERAL:

This spreader is designed to mount rigidly on the rear of the truck dump body, below the tailgate, and supported by brackets bolted to the rub rails of the dump body. Instructional drawing is included in this manual to show the details on page 11.

### DANGER

Support spreader and other heavy components solidly when positioning for mounting on truck dump body.

### IMPORTANT:

On occasion, due to improper handling during shipment or storage, the vertical ends of the trough get bent in or out slightly. Be sure these are square and true before installation. Once installed, the mounting brackets should prevent further deformation.

1. Position the spreader under the dump body tailgate with the auger drive housing to the right side of the truck. The trough lip on the forward side of the spreader should be as close as possible to the cross member under the floor of the dump body.

The tailgate of the dump body should lay down horizontally over the spreader, yet the spreader must be mounted up under the tailgate as high as possible.

2. Pin quick detach plates to spreader detach brackets.
3. Position quick detach plates against dump body cornerposts and clamp in a level position. Weld adequately to support loaded spreader trough. If bolting, is desired, drill (2) holes for 1/2" bolts simultaneously through bracket, cornerpost and bolt solidly.
4. Position hanger iron brace on brace pin located on spreader endplates.
5. Locate brace pins on dump body cornerposts approximately as shown using braces for exact positioning. (Braces may require bending for proper fit.)
6. Weld brace pins solidly to dump body, and retain braces at each end with hairpin keepers.
7. Carefully remove temporary spreader positioning apparatus.
8. If there is a gap between the trough lip and the dump body rear cross member, a "spillboard" of about 3/16" x 2" steel may be welded or bolted to the forward lip of the spreader to form a seal under the dump body floor. It may have to be notched or cut to fit around tailgate latches or other obstructions on the rear of the dump body.

# SEL INSTALLATION AND OPERATING INSTRUCTION MANUAL

## INSTALLATION OF SPINNER ASSEMBLY ON “SEL” SERIES SPREADERS

 **DANGER** SUPPORT SPINNER ASSEMBLY SOLIDLY WHEN MOUNTING ON SPREADER.

---

### **SPINNER ASSEMBLY PROCEDURE:**

1. Attach spinner disc to hub with 5/16” x 1 1/2” bolts, flatwashers and flange nuts.
2. Apply anti-seize compound to spinner motor shaft.
3. Mount spinner disc/hub assembly on spinner motor shaft.
4. Secure disc/hub assembly to motor shaft with proper size hardware (provided). Bolt should engage threads in motor shaft a minimum of 3/8” when bolt is tight.
5. Attach spinner frame assembly to spinner extension mounting bracket with (4) 3/8” X 1” bolts and flange nuts.
  - a. Appropriate spinner height depends on truck frame ground clearance. A shorter spinner height for light and medium duty trucks with contractor style bodies, a taller spinner height for heavy duty trucks with full size dump bodies.
6. While holding lock collar in middle notch of spinner extension mounting bracket, slide spinner hinge rod through both the mounting bracket and lock collar.
7. Pin spinner carriage bracket to the trough and bottom door. Insert lynch pins

### **MOUNTING PROCEDURES:**

TRUCK SHOULD BE ON LEVEL SURFACE.

1. Install spinner assembly on spreader by sliding the hinge rod into the mounting tabs on bottom door. Insert (2) keeper pins into hinge rod. Center and lock spinner assembly between mounting tabs.
2. Raise and lower dump body to check spinner ground clearances. Adjust spinner height if needed. Repeat step if adjustments are made.

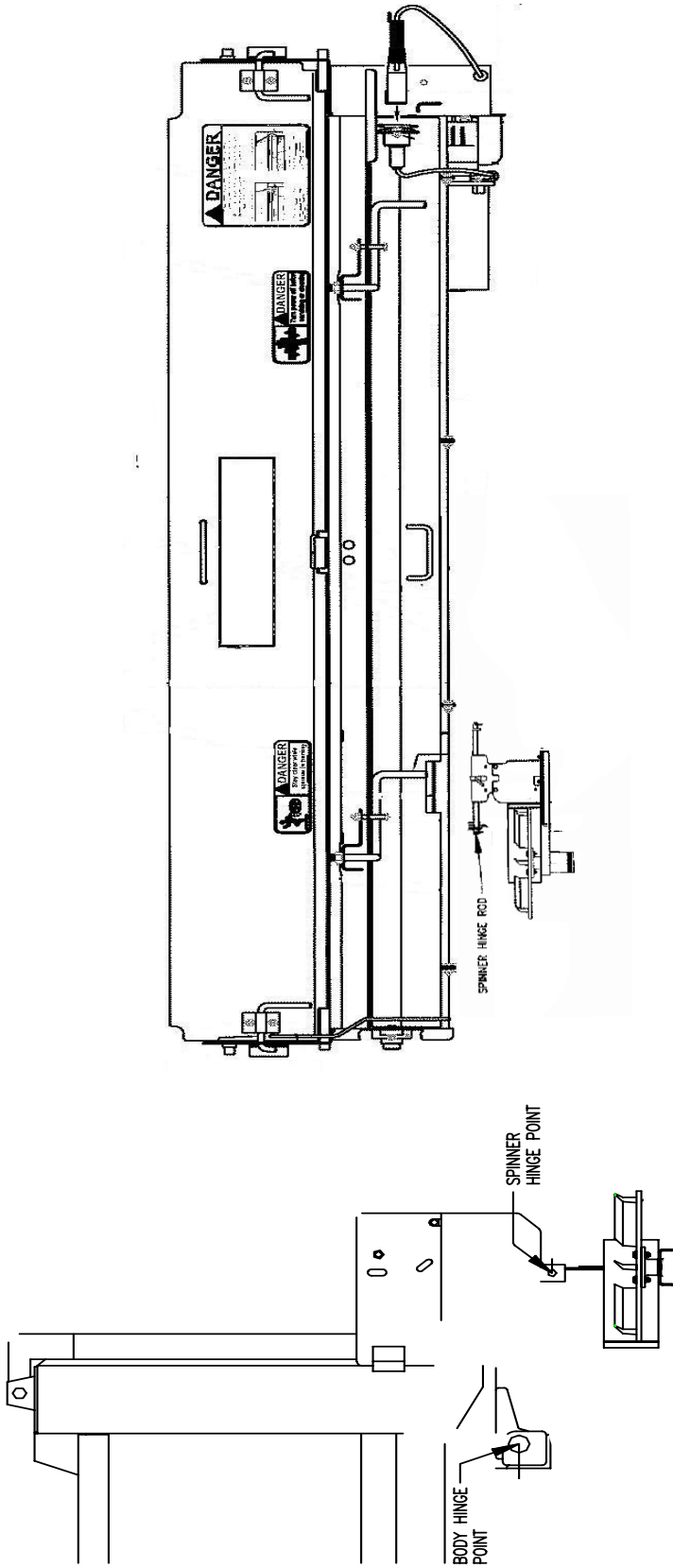

This diagram to used as refer-  
ence only

LEFT HAND (CCW) SPINNER ASSEMBLY  
S SFRIFS SPRFANFR

## ADJUSTING SPINNER FOR DESIRED SPREAD PATTERN



### DANGER!

Serious personal injury can result from being caught in a turning spinner. Stay clear and keep all others clear when spinner is turning.

Serious personal injury can result if hit by flying particles being thrown by a turning spinner.

Stand back, and keep all others back at least 50 feet while spinner is turning. **DO NOT ASSUME that particles cannot be thrown by a turning spinner just because material is not being dropped onto the spinner; particles that have been sticking to the spinner may suddenly come loose and be thrown causing possible injury.**

In general, for the most commonly desired spread patterns, the material drop zone should be **over forward half** and **within outside edge of disc**. See below and next page. Adjusting the specific location where material falls on the forward half of the spinner disc is very important. This allows the greatest portion of the material to be placed on the road surface in the three most commonly desired locations:  
 1. To the left of the vehicle. 2. To the left and rear of the vehicle. 3. To the rear and right of the vehicle.

The spinner shield which is positioned approximately at the right forward quadrant of the spinner disc, is intended to restrict "stray" material to the spinner area and to aid in a more defined spread pattern.

Once the desired spread pattern has been obtained, increasing the spinner speed by opening the spinner control knob will give a wider spread pattern, and closing the spinner control knob will give a narrower spread pattern.

It should be noted that the spread pattern width will vary as the dump body is raised and lowered during spreading operations. This is due to the spinner becoming closer to the road surface as the body is raised, and farther away from the road surface as the body is lowered. A higher spinner assembly above the road surface will give a wider spread pattern, and a lower spinner assembly above the road surface will give a narrower spread pattern. When establishing spread pattern width, raise the body to the dump angle normally used during spreading operations, and have the spinner control knob at the setting normally used during spreading operations.

Sliding the spinner to intermediate positions from those shown below and on the following page will give variations of spread patterns to those shown. After establishing the desired spread pattern, it is suggested that the spinner position on the hinge rod, the dump body angle, and the valve spinner control setting be recorded for future use.

**IMPORTANT!** After making final adjustments, the spinner assembly must always be locked in position using the provided locking mechanism.

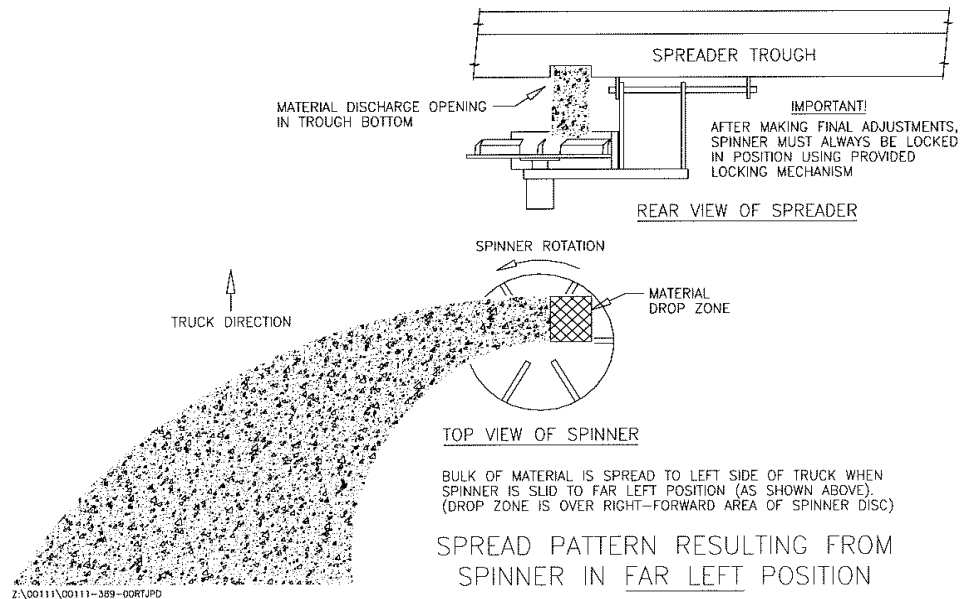

## Spread pattern adjustment, cont'd

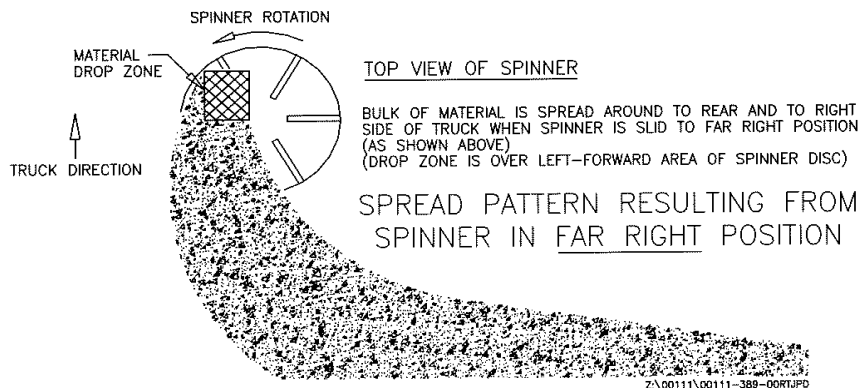
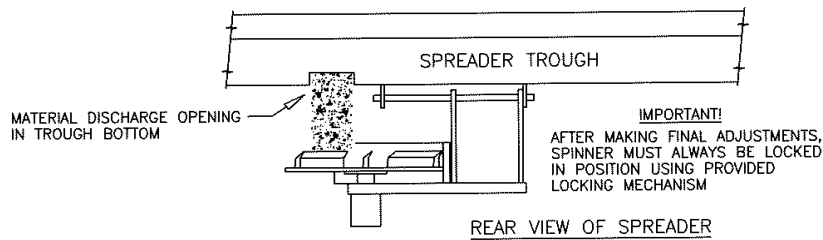
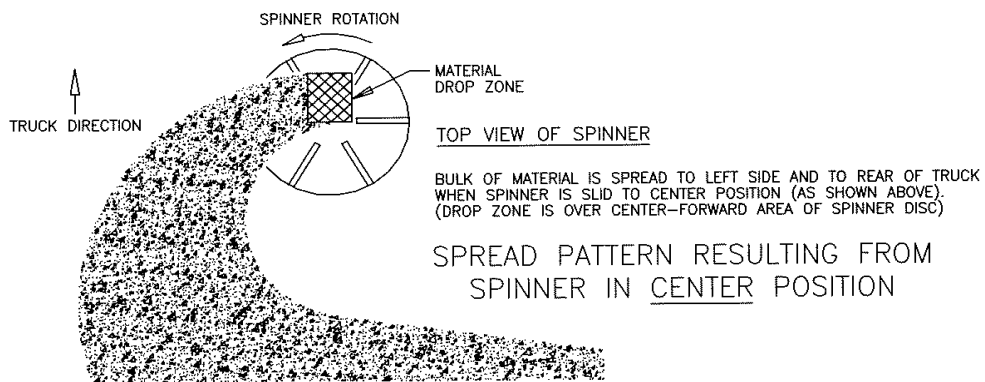
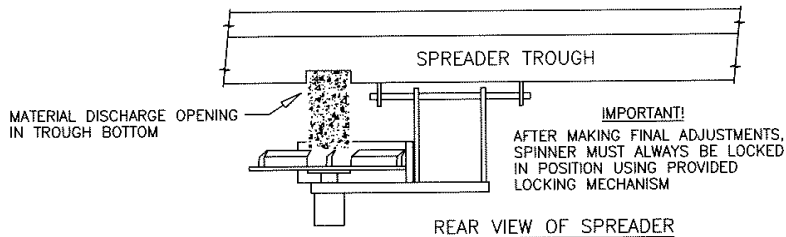



### **DANGER**

1. WHEN STARTING UP NEW EQUIPMENT, BE SURE EVERYONE IS STANDING CLEAR, WATCH FOR ANYTHING THAT MAY REQUIRE SHUTTING SYSTEM DOWN. EQUIPMENT MUST BE STARTED UP SLOWLY AND WATCHED FROM A SAFE DISTANCE. WATCH FOR ANYTHING THAT MAY BE HITTING SOMETHING THAT IT SHOULD NOT BE HITTING, AND LISTEN FOR SOUNDS THAT ARE ABNORMAL. CORRECT ANYTHING THAT IS ABNORMAL BEFORE CONTINUING USE OF THE EQUIPMENT.
2. BEFORE INSTALLATION, MAINTENANCE, CLEANING, OR REMOVAL OF SPREADER, ALL ELECTRICAL CONNECTIONS MUST BE DISCONNECTED

#### **INITIAL START UP:**

This spreader is equipped with a electrical safety interlock device designed to interrupt electrical flow to the auger motor when disconnected. The spreader is shipped with the interlock device in the disconnected position and must be connected for operating the spreader.

1. Connect electrical harnesses to safety interlock, spreader and spinner.
2. Keep auger and spinner knobs on controller to zero position.
3. Push power switch to "ON" position.
4. Examine auger and spinner to see if they are functioning properly. (They will be operating slowly.)  
(Left hand mounted spinner should turn in CCW rotation as viewed from above spinner.,  
Auger should turn in direction which makes auger fliting appear to move towards trough dropout opening.)
5. Open control knobs to other positions and check to see if spinner and auger operate faster as knobs are opened, and slower as knobs are closed.
6. Open knobs to other positions and check to see if spinner and auger operate faster as knobs are adjusted.
7. Shut power switch to off

## OPERATING INSTRUCTIONS

(Continued)

### PREPARING SPREADER FOR USE:

1. Position spreader cover plate vertically and secure with latches.
2. With dump body empty, unlatch dump body tailgate from bottom and open as wide as possible but not bearing against cover plate, set the stop (or spread) chains.
3. Loosen spinner lock and slide spinner assembly to far left and retighten lock. (Position for spreading three or four lane highway from right lane.)
4. Put spreading material in dump body and raise dump body to fill spreader trough.
5. Lower dump body to safe position.
6. Press controller power switch to "ON" position. Spread small amount of material to determine placement of material at various spinner and auger speeds with spinner in this far left position.
7. Press controller switch to "OFF" position and shut off truck engine.
8. Loosen spinner lock and slide spinner assembly to far right and retighten lock. (Position for spreading behind truck and to extreme right covering up to four lanes from left lane.)
9. Start truck engine.
10. Press controller switch to "ON" position. Spread small amount of material to determine placement of material at various spinner and auger speeds with spinner in this far right position.
11. It should now be visible that various spread patterns may be obtained by placing spinner at various positions from left to right, and by changing spinner speeds on valve.

### OPERATING SPREADER:

1. For operating electrical system, follow same procedures as for preparing spreader for use.
2. Any speed knob setting changes may be made while truck is in motion.
3. Spinner and auger may be stopped at the same time, without changing their valve settings, by pressing power switch to "OFF" position.
4. For normal use of dump truck, cover plate may be laid flat over spreader trough and locked in place. Dump body tailgate may be opened from top or bottom.
5. When using truck for normal hauling and dumping, it is recommended that electrical safety interlock be disconnected. Push dust cap onto disconnect.
6. Refer to safety interlock danger decal on trough cover plate for proper use of safety interlock.
7. To avoid spinner damage, spinner may be removed when truck is used for extensive hauling. Protect electric disconnects with appropriate plugs and caps.

### **DANGER**

**SERIOUS PERSONAL INJURY CAN RESULT FROM BEING CAUGHT IN A TURNING AUGER, A TURNING SPINNER, OR OTHER OPERATING TRUCK EQUIPMENT. BEFORE PERFORMING MAINTENANCE OPERATIONS, PARK VEHICLE ON LEVEL GROUND. SET PARKING BRAKE, SHUT OFF ALL POWER, AND SHUT OFF TRUCK ENGINE. ALWAYS REPLACE SHIELDS AND COVERS WHEN MAINTENANCE IS COMPLETE.**

1. Clean electrical plugs before taking apart or connecting.
2. Protect electrical plugs while in use and after taking apart with dust caps or other suitable protection.
3. Auger bearing requires periodic greasing every 15 hours of use and more frequent greasing during periods of greater use.
4. Greasing spinner hinge rod at support pivot points is suggested.
5. Hosing down and cleaning spreader after each use, and repainting or oiling after each season will greatly prolong spreader life. To open bottom door and top cover, disconnect electrical safety interlock and pivot around to end of spreader.
6. Spreader trough should be completely emptied after each use during severe cold weather to prevent material from freezing around auger.

**PARTS LISTING**

**TOP VIEW SHOWN WITHOUT TOP COVER  
AND HOLD DOWN CLIPS  
64019 (CS TROUGH ASSY)  
64020 (SS TROUGH ASSY)  
64021 (CS CD TROUGH ASSY)  
64022 (SS CD TROUGH ASSY)**

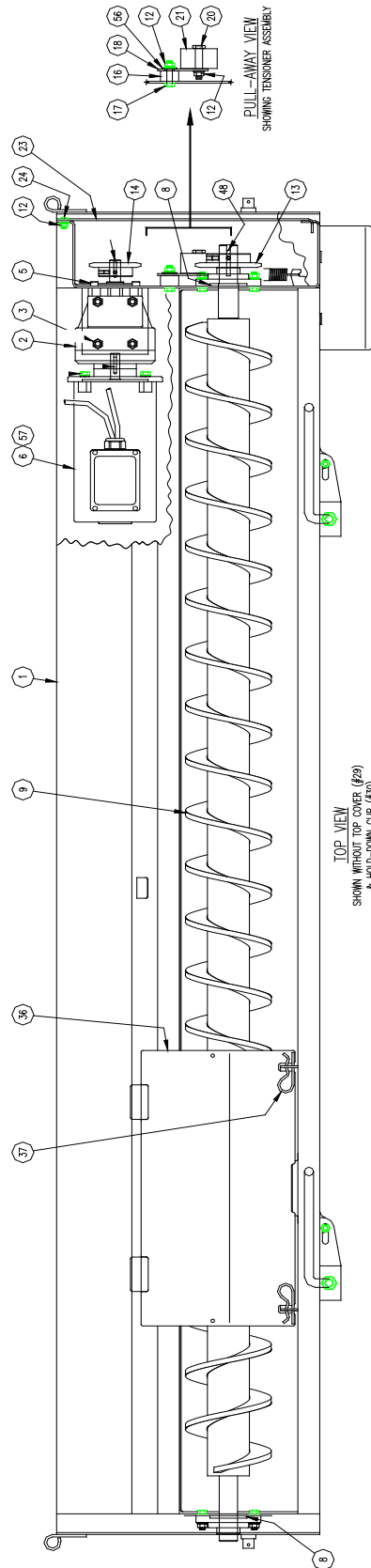

# SEL INSTALLATION AND OPERATING INSTRUCTION MANUAL

## PARTS LIST

**64019 (CS TROUGH ASSY)**

**64020 (SS TROUGH ASSY)**

**64021 (CS CD TROUGH ASSY)**

**64022 (SS CD TROUGH ASSY)**

| ITEM   | PART NUMBER | QTY | DESCRIPTION                               |
|--------|-------------|-----|---|
| 1 CS   | 64025       | 1   | WELD, TROUGH, 10G CS                      |
| CS C/D | 64026       | 1   | WELD, TROUGH, 10 GA CS CENTER DROP        |
| SS     | 64027       | 1   | WELD, TROUGH 10 G S2                      |
| SS C/D | 64028       | 1   | WELD, TROUGH, 10 GA S2 CENTER DROP        |
| 2      | 64029       | 1   | REDUCER, GEAR 29.4:1                      |
| 3      | 64030       | 4   | BOLT, M10-1.5 X 20 SCH SS                 |
| 5      | 63993       | 5   | SCREW, M8-1.25 X 20 SCH SS                |
| 6      | 64015       | 1   | MOTOR, 12 V 1650 RPM 60 A 1/2 HP          |
| 8      | 62480       | 1   | WASHER, FELT 1 1/4" ID X 2 1/2" OD        |
| 9      | 63051       | 1   | WELD, AUGER, SA (2 1/2" TUBE)             |
|        | 64031       | 1   | WELD, AUGER, SA (2 1/2" TUBE) CENTER DROP |
| 12 CS  | 62611       | 9   | NUT, 3/8-16 SER FLANGE ZP                 |
| SS     | 62743       | 9   | NUT, 3/8-16 SER FLANGE SS                 |
| 13     | 64032       | 1   | SPROCKET, 50BL21-1 1/4" BORE              |
| 14     | 64033       | 1   | SPROCKET, 50BL16-3/4" BORE                |
| 16     | 64034       | 1   | BUSHING, TENSIONER STANDOFF S3            |
| 17 CS  | 20051       | 1   | BOLT, 3/8-16 X 1 1/2" HH G5 ZP            |
| SS     | 64035       | 1   | BOLT, 3/8-16 1 1/2" HH SS                 |
| 18 CS  | 64037       | 1   | PLATE, WHEEL TENSIONER 10G CS             |
| SS     | 64037       | 1   | PLATE, WHEEL TENSIONER 10G S2             |
| 20     | 64038       | 1   | BOLT, SHOULDER 1/2 X 1 1/2" HH            |
| 21     | 64039       | 1   | ROLLER, THNSIONER UHMW                    |
| 23 CS  | 64040       | 1   | COVER, CHAIN 10G CS                       |
| SS     | 64041       | 1   | COVER, CHAIN 10G S2                       |
| 24 CS  | 63994       | 3   | BOLT, 3/8-16 X 3/4" CA G5 ZP              |
| SS     | 62746       | 3   | BOLT, 3/8-16 X 3/4" CA SS                 |
| 36 CS  | 64042       | 1   | COVER, ANTI-FLOW 10G CS                   |
| SS     | 64043       | 1   | COVER, ANTI-FLOW 10G S2                   |
| 37 CS  | 61233       | 2   | KEEPER, HAIRPIN LARGE                     |
| SS     | 63193       | 2   | KEEPER, HAIRPIN LARGE SS                  |
| 48     | 60421       | 1   | KEY, 1/4: SQ. X 1 1/4"                    |
| 56 CS  | 64044       | 1   | FLATWASHER, 3/8" U.S.S. ZP                |
| SS     | 63565       | 1   | FLATWASHER, 3/8" U.S.S. SS                |
| 57     | 64024       | 4   | SCREW, M6-1.0 X 10 SCH SS                 |

**REAR VIEW**  
**64019 (CS TROUGH ASSY)**  
**64020 (SS TROUGH ASSY)**  
**64021 (CS CD TROUGH ASSY)**  
**64022 (SS CD TROUGH ASSY)**

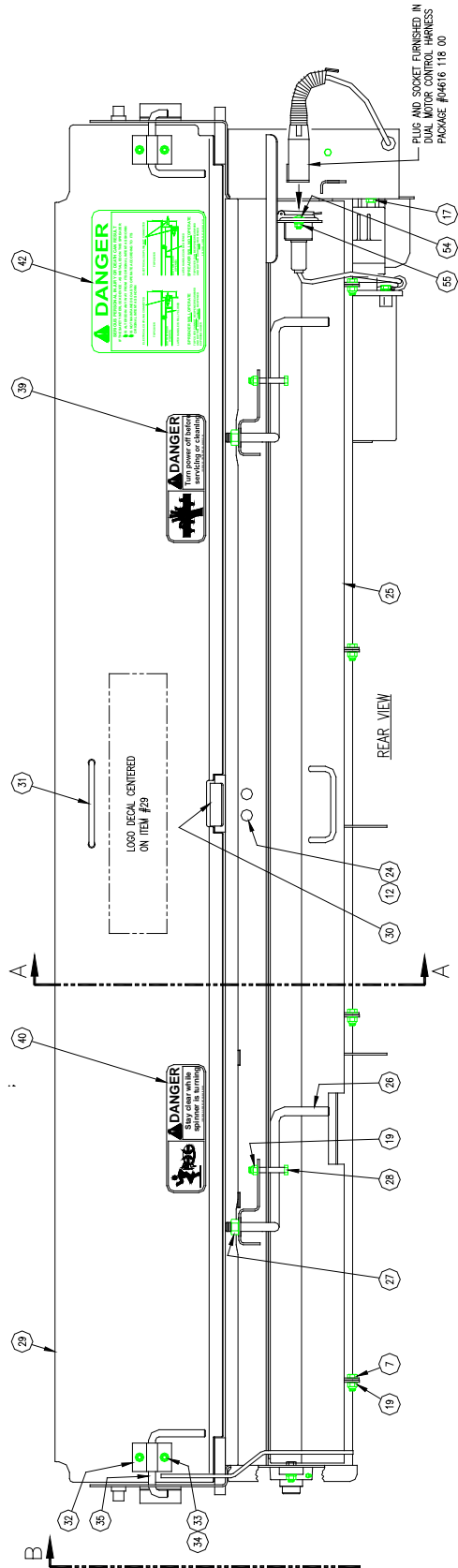

# SEL INSTALLATION AND OPERATING INSTRUCTION MANUAL

## PARTS LIST CONT'D

**64019 (CS TROUGH ASSY)**

**64020 (SS TROUGH ASSY)**

**64021 (CS CD TROUGH ASSY)**

**64022 (SS CD TROUGH ASSY)**

| ITEM   | PART NUMBER | QTY. | DESCRIPTIONS                          |
|--------|-------------|------|---------------------------------------|
| 7 CS   | 20049       | 4    | BOLT, 3/8-16 X 1 HH G5 ZP             |
| SS     | 62697       | 4    | BOLT, 3/8-16 X 1 HH SS                |
| 12 CS  | 62611       | 9    | NUT, 3/8-16 SER FLANGE ZP             |
| SS     | 62743       | 9    | NUT, 3/8-16 SER FLANGE SS             |
| 17 CS  | 20051       | 1    | BOLT, 3/8-16 X 1 1/5" HH G5 ZP        |
| SS     | 64035       | 1    | BOLT, 3/8-16 X 1 1/2" HH SS           |
| 19 CS  | 20305       | 8    | LOCKNUT, 3/8-16 NI ZP                 |
| SS     | 63348       | 8    | LOCKNUT, 3/8-16 NI SS                 |
| 24 CS  | 63994       | 3    | BOLT, 3/8-16 X 3/4" CA G5 ZP          |
| SS     | 62746       | 3    | BOLT, 3/8-16 X 3/4" CA SS             |
| 25 CS  | 64045       | 1    | WELD, BOTTOM DOOR 10 G CS             |
| CS C/D | 64046       | 1    | WELD, BOTTOM DOOR, 10G CD CENTER DROP |
| SS     | 64047       | 1    | WELD, BOTTOM DOOR 10G SS              |
| SS C/D | 64048       | 1    | WELD, BOTTOM DOOR 10G SS CENTER DROP  |
| 26     | 64003       | 2    | LATCH, BOTTOM DOOR CS                 |
|        | 64004       | 2    | LATCH, BOTTOM DOOR S3                 |
| 27 CS  | 63279       | 2    | LOCKNUT, 5/8-11 TOP LOCK ZP           |
| SS     | 63425       | 2    | LOCKNUT, 5/8-11 TOP LOCK SS           |
| 28 CS  | 20068       | 2    | BOLT, 3/8-16 X 2 1/2" HH G5 ZP        |
| SS     | 63198       | 2    | BOLT, 3/8-16 X 2 1/2" HH SS           |
| 29 CS  | 64049       | 1    | WELD, TOP COVER 10G CS                |
| SS     | 64050       | 1    | WELD, TOP COVER 10G S2                |
| 30 CS  | 64051       | 1    | CLIP, HOLD-DOWN 10 G CS               |
| SS     | 64052       | 1    | CLIP, HOLD-DOWN 10 G S2               |
| 31 CS  | 64053       | 1    | HANDLE, LIFT CS                       |
| SS     | 64054       | 1    | HANDLE, LIFT S3                       |
| 32     | 63280       | 2    | BRACKET, S2                           |
| 33     | 63283       | 4    | BOLT, 5/16-18 X 5/8" CA SS            |
| 34     | 63310       | 4    | NUT, 5/16-18 SER FLANGE SS            |
| 35 CS  | 62443       | 2    | FORMING, HANDLE, ZP                   |
| SS     | 62731       | 2    | HANDLE, SS                            |
| 39     | 62515       | 1    | DECAL, DANGER (AUGER)                 |
| 40     | 62006       | 1    | DECAL, DANGER (SPINNER)               |
| 42     | 64018       | 1    | DECAL, SAFETY INTERLOCK ELECTRIC      |
| 54 CS  | 63305       | 2    | BOLT, 5/16-18 X 3/4" CA G5 ZP         |
| SS     | 62640       | 2    | BOLT, 5/16-18 X 3/4" CA SS            |
| 55     | 63304       | 2    | NUT, 5/16-18 X 3/4" CA G5 ZP          |
|        | 63310       | 2    | NUT, 5/16-18 X 3/4" CA SS             |

**CROSS SECTIONAL VIEW  
(REAR VIEW SECTION A-A)  
END PLATE VIEW**  
**64019 (CS TROUGH ASSY)**  
**64020 (SS TROUGH ASSY)**  
**64021 (CS CD TROUGH ASSY)**  
**64022 (SS CD TROUGH ASSY)**

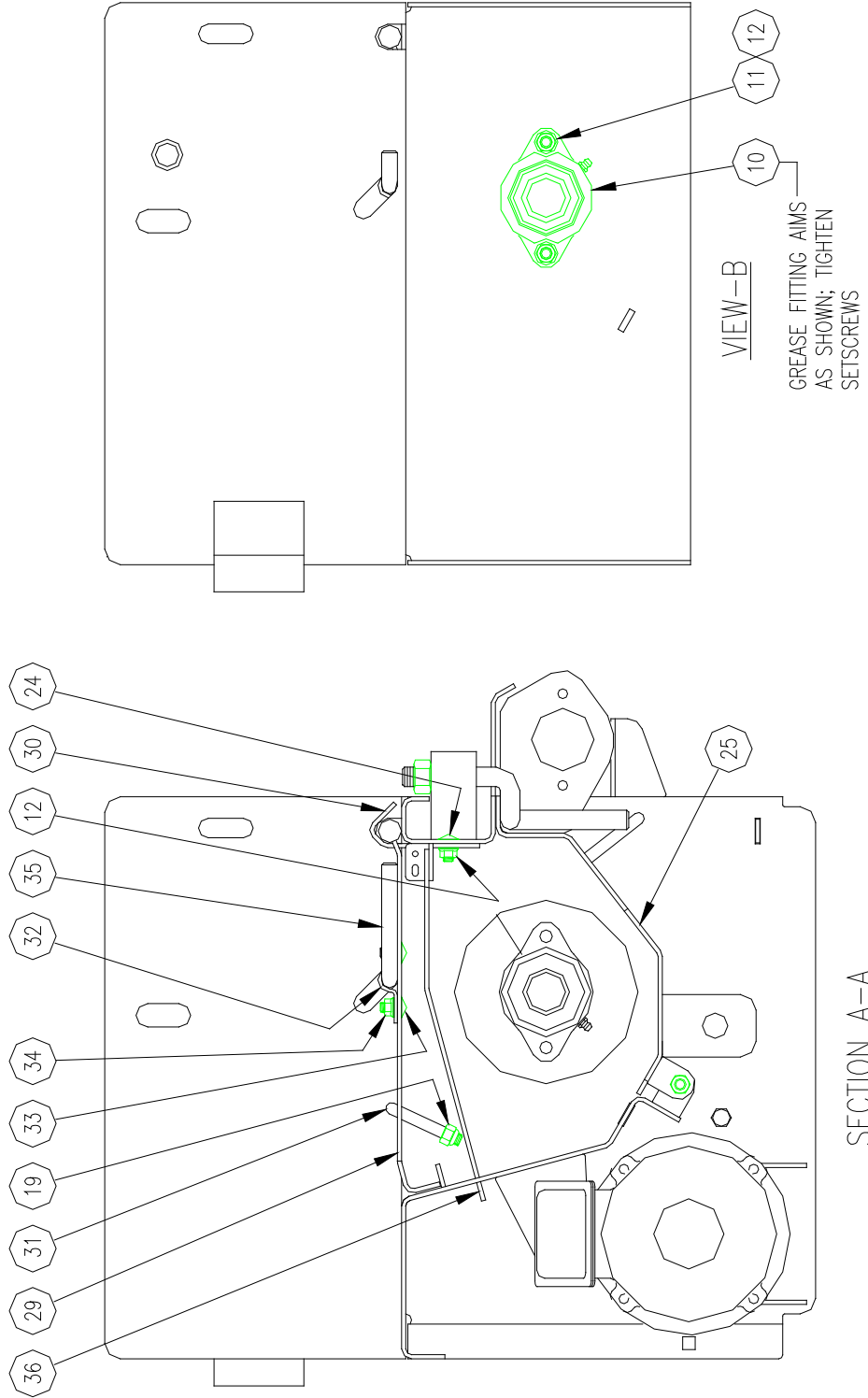

# SEL INSTALLATION AND OPERATING INSTRUCTION MANUAL

## PARTS LIST CONT'D

**64019 (CS TROUGH ASSY)**

**64020 (SS TROUGH ASSY)**

**64021 (CS CD TROUGH ASSY)**

**64022 (SS CD TROUGH ASSY)**

| ITEM  | PART NUMBER | QTY | DESCRIPTION                    |
|-------|-------------|-----|--------------------------------|
| 10    | 61163       | 2   | BEARING, 1 1/4"                |
| 11 CS | 20066       | 4   | BOLT, 3/8-16 Z 1 1/4" HH G5 ZP |
| SS    | 62695       | 4   | BOLT, 3/8-16 X 1 1/4" HH SS    |
| 12 CS | 62611       | 9   | NUT, 3/8-16 SER FLANGE ZP      |
| SS    | 62743       | 9   | NUT, 3/8-16 SER FLANGE SS      |
| 19 CS | 20305       | 8   | LOCKNUT, 3/8-16 NI ZP          |
| SS    | 62638       | 8   | LOCKNUT, 3/8-16 NI SS          |
| 24 CS | 63394       | 3   | BOLT, 3/8-16 X 3/4" CA G5 ZP   |
| SS    | 62746       | 3   | BOLT, 3/8-16 X 3/4" CA SS      |
| 29 CS | 64049       | 1   | WELD, TOP COVER 10G CS         |
| SS    | 64050       | 1   | WELD, TOP COVER 10G S2         |
| 30 CS | 64051       | 1   | CLIP, HOLD-DOWN 10 G CS        |
| SS    | 64052       | 1   | CLIP, HOLD-DOWN 10 G S2        |
| 31 CS | 64053       | 1   | HANDLE, LIFT CS                |
| SS    | 64052       | 1   | HANDLE, LIFT S3                |
| 32    | 63280       | 2   | BRACKET, S2                    |
| 33    | 63283       | 4   | BOLT, 5/16-18 X 5/8" CA SS     |
| 34    | 63310       | 4   | NUT, 5/16-18 SER FLANGE SS     |
| 35 CS | 62443       | 2   | FORMING, HANDLE, ZP            |
| SS    | 62731       | 2   | HANDLE, SS                     |
| 36 CS | 64042       | 1   | COVER, ANTI-FLOW 10 G CS       |
| SS    | 64043       | 1   | COVER, ANTI-FLOW 10G S2        |

# SEL INSTALLATION AND OPERATING INSTRUCTION MANUAL

## DRIVE END VIEW

64019 (CS TROUGH ASSY)

64020 (SS TROUGH ASSY)

64021 (CS CD TROUGH ASSY)

64022 (SS CD TROUGH ASSY)

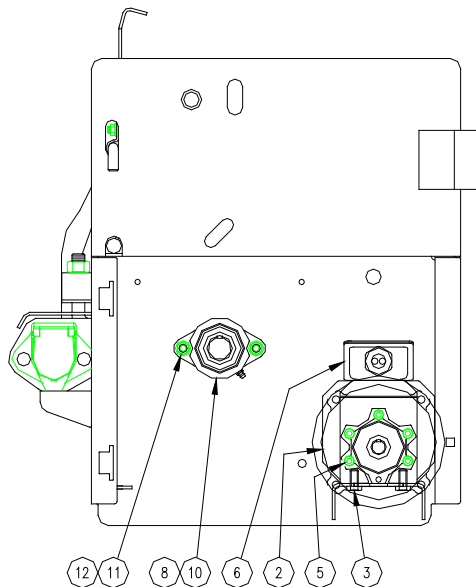

GREASE FITTING AIMS AS SHOWN; TIGHTEN SETSCREWS  
**DRIVE END VIEW**  
 SHOWN WITHOUT SPROCKETS, ROLLER CHAIN, SPRING, & TENSIONER PARTS

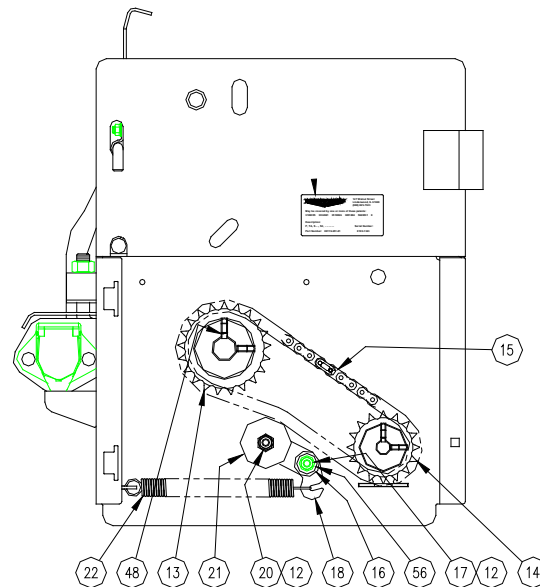

**DRIVE END VIEW**  
 SHOWN WITH SPROCKETS, ROLLER CHAIN, SPRING, & TENSIONER PARTS

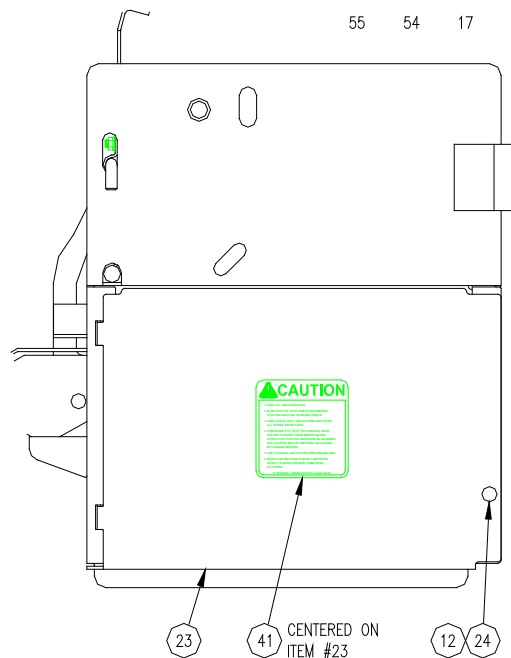

**DRIVE END VIEW**  
 SHOWING CHAIN COVER & CAUTION DECAL

# SEL INSTALLATION AND OPERATING INSTRUCTION MANUAL

## PARTS LIST CONT'D

**64019 (CS TROUGH ASSY)**  
**64020 (SS TROUGH ASSY)**  
**64021 (CS CD TROUGH ASSY)**  
**64022 (SS CD TROUGH ASSY)**

| ITEM  | PRODUCT | QTY | DESCRIPTION                        |
|-------|---------|-----|------------------------------------|
| 2     | 64029   | 1   | REDUCER, GEAR 29.4:1               |
| 3     | 64030   | 4   | BOLT, M10-1.5 X 20 SCH SS          |
| 5     | 63993   | 5   | SCREW, M8-1.25 X 20 SCH SS         |
| 6     | 64015   | 1   | MOTOR, 12 V 1650 RPM 60 A 1/2 HP   |
| 8     | 62480   | 1   | WASHER, FELT 1 1/4" ID X 2 1/2" OD |
| 10    | 61163   | 2   | BEARING, 1 1/4"                    |
| 11 CS | 20066   | 4   | BOLT, 3/8-16 Z 1 1/4" HH G5 Z      |
| SS    | 62695   | 4   | BOLT, 3/8-16 X 1 1/4" HH SS        |
| 12 CS | 62611   | 9   | NUT, 3/8-16 SER FLANGE ZP          |
| SS    | 62743   | 9   | NUT, 3/8-16 SER FLANGE SS          |
| 13    | 64032   | 1   | SPROCKET, 50BL21-1 1/4" BORE       |
| 14    | 64033   | 1   | SPROCKET, 50BL16-3/4" BORE         |
| 15    | 64056   | 1   | CHAIN, ROLLER #50-48 PITCH W/C     |
| 16    | 64034   | 1   | BUSHING, TENSIONER STANDOFF S3     |
| 17 CS | 20051   | 1   | BOLT, 3/8-16 X 1 1/5" HH G5 ZP     |
| SS    | 64035   | 1   | BOLT, 3/8-16 X 1 1/2" HH SS        |
| 18 CS | 64036   | 1   | PLATE, WHEEL TENSIONER 10G CS      |
| SS    | 64037   | 1   | PLATE, WHEEL TENSIONER 10G S2      |
| 20    | 64038   | 1   | BOLT, SHOULDER 1/2 X 1 1/2" HH     |
| 21    | 64039   | 1   | ROLLER, TENSIONER UHMW             |
| 22    | 64057   | 1   | SPRING, EXTENSION 6"               |
| 23 CS | 64040   | 1   | COVER, CHAIN 10G CS                |
| SS    | 64041   | 1   | COVER, CHAIN 10G S2                |
| 24 CS | 63994   | 3   | BOLT, 3/8-16 X 3/4" CA G5 ZP       |
| SS    | 62746   | 3   | BOLT, 3/8-16 X 3/4" CA SS          |
| 41    | 62007   | 1   | DECAL, CAUTION                     |
| 48    | 60421   | 1   | KEY, 1/4: SQ. X 1 1/4"             |
| 56 CS | 64035   | 1   | FLAT WASHER, 3/8" U.S.S. ZP        |
| SS    | 63565   | 1   | FLAT WASHER, 3/8" U.S.S. SS        |

Assembled Spinner Image

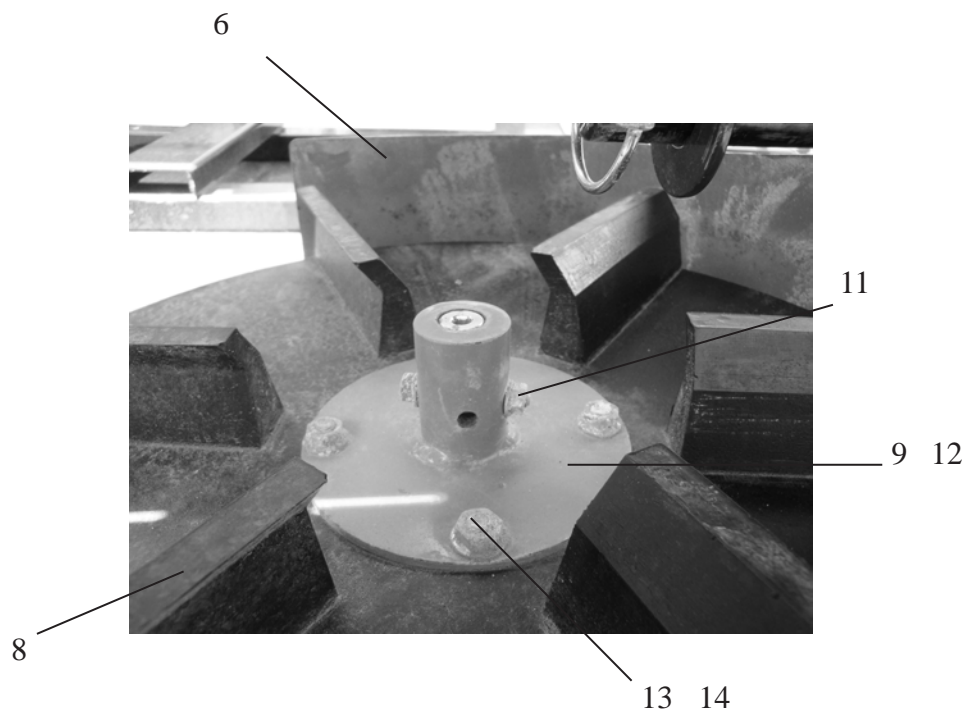
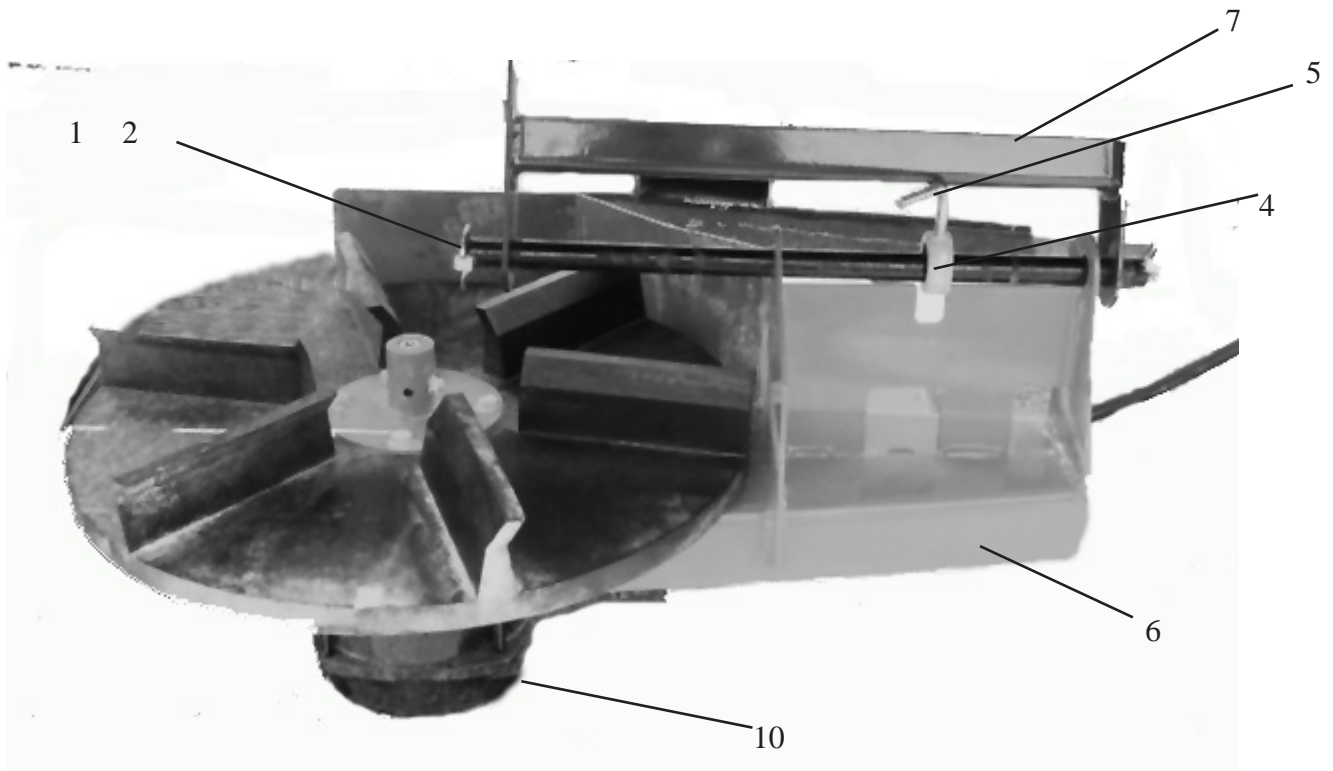

# SEL INSTALLATION AND OPERATING INSTRUCTION MANUAL

## Assembled Spinner Image Parts Listing

| ITEM | PRODUCT | QTY | DESCRIPTION                     |
|------|---------|-----|---------------------------------|
| 1    | 63271   | 2   | ROD, HINGE, S3                  |
| 2    | 22083   | 4   | PIN, LYNCH                      |
| NS   | 63447   | 1   | ROD, CARRIAGE SUPPORT S3        |
| 4    | 62769   | 1   | COLLAR, SET 1"                  |
| 5    | 62459   | 1   | LOCK, SPINNER, S3               |
| 6 CS | 64009   | 1   | WELD, SPINNER FRAME 10G CS      |
| SS   | 64010   | 1   | WELD, SPINNER FRAME 10G SS      |
| 7 CS | 64011   | 1   | WELD, SPINNER CARRIAGE, 10 G CS |
| SS   | 64012   | 1   | WELD, SPINNER CARRIAGE, 10G SS  |
| 8    | 64013   | 1   | DISC, POY 18" 1.62 BORE CCW     |
| 9 CS | 64014   | 1   | WELD, SPINNER HUB CS            |
| 10   | 64015   | 1   | MOTOR, 12V 1650rpm 60A 1/2 HP   |
| 11   | 64016   | 1   | BOLT, M6-1.0 X 40 mm HH SS      |
| 12   | 64017   | 1   | LOCKNUT M6-1.0 TOP LOCK SS      |
| 13   | 63268   | 4   | BOLT, 5/16 - 18 X 1 1/4" HH SS  |
| 14   | 62743   | 5   | NUT, 5/16 SER FLANGE SS         |
| NS   | 62695   | 4   | BOLT, 3/8-16 X 1 1/4" HH SS     |
| NS   | 22230   | 4   | FLATWASHER, 3/8" U.S.S. SS      |
| NS   | 62743   | 4   | NUT, 3/8-16 SER FLANGE SS       |

# SEL INSTALLATION AND OPERATING INSTRUCTION MANUAL

## CARRIAGE MOUNTING EXPLODED VIEW

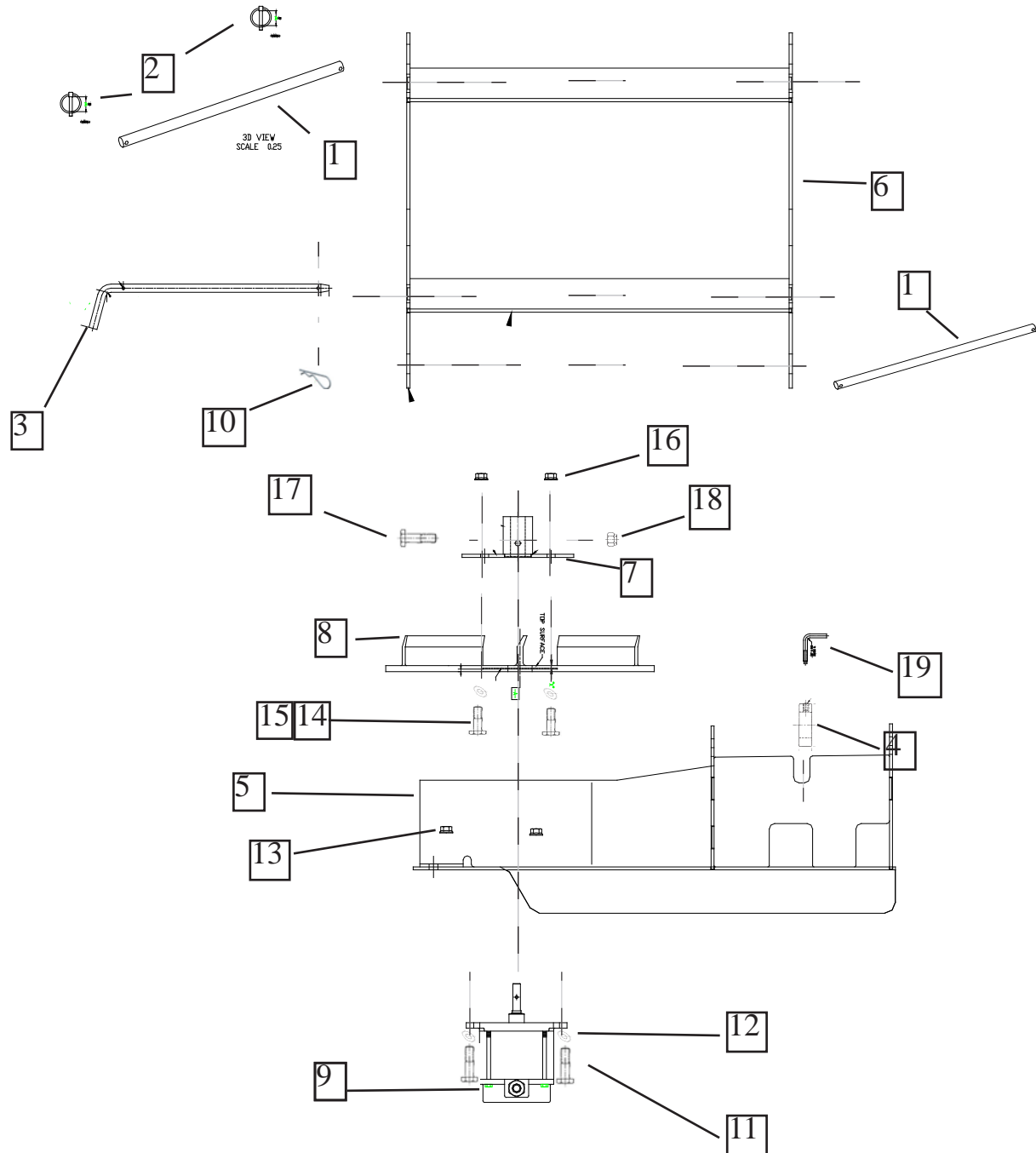

**SEL INSTALLATION AND OPERATING INSTRUCTION MANUAL**  
**FRONT MOUNTED SPINNER CARRIAGE**  
**ASSEMBLY PARTS LIST**

| ITEM | PRODUCT  | QTY | DESCRIPTION                     |
|------|----------|-----|---------------------------------|
| 1    | 63271    | 2   | ROD, HINGE, S3                  |
| 2    | 22083    | 4   | PIN, LYNCH                      |
| 3    | 63447    | 1   | ROD, CARRIAGE SUPPORT S3        |
| 4    | 62769    | 1   | COLLAR, SET 1"                  |
| 5    | CS 64009 | 1   | WELD, SPINNER FRAME 10G CS      |
|      | SS 64010 | 1   | WELD, SPINNER FRAME 10G SS      |
| 6    | CS 64011 | 1   | WELD, SPINNER CARRIAGE, 10 G CS |
|      | SS 64012 | 1   | WELD, SPINNER CARRIAGE, 10G SS  |
| 7    | 64013    | 1   | DISC, POY 18" 1.62 BORE CCW     |
| 8    | CS 64014 | 1   | WELD, SPINNER HUB CS            |
| 9    | 64015    | 1   | MOTOR, 12V 1650rpm 60A 1/2 HP   |
| 10   | 63193    | 1   | KEEPER, HAIRPIN LARGE, SS       |
| 11   | 62695    | 4   | BOLT, 3/8-16 X 1 1/4" HH SS     |
| 12   | 22230    | 4   | FLAT WASHER, 3/8" U.S.S. SS     |
| 13   | 62743    | 4   | NUT, 3/8-16 SER FLANGE SS       |
| 14   | 63268    | 4   | BOLT 5/16-18 X 1/1/4" HH SS     |
| 15   | 63173    | 5   | FLATWASHER 5/16 U.S.S. SS       |
| 16   | 63310    | 5   | NUT 5/16-18 SER FLANGE SS       |
| 17   | 64016    | 1   | BOLT, M6-1.0 X 40 mm HH SS      |
| 18   | 64017    | 1   | LOCKNUT, M6-1.0 TOP LOCK SS     |
| 19   | 62459    | 1   | LOCK, SPINNER, S3               |
| NS   | 62273    | 1   | BOLT 5/16-18 1 1/2" HH SS       |

## NAME PLATE INFORMATION

### EXPLANATION OF SERIAL NUMBER DECAL

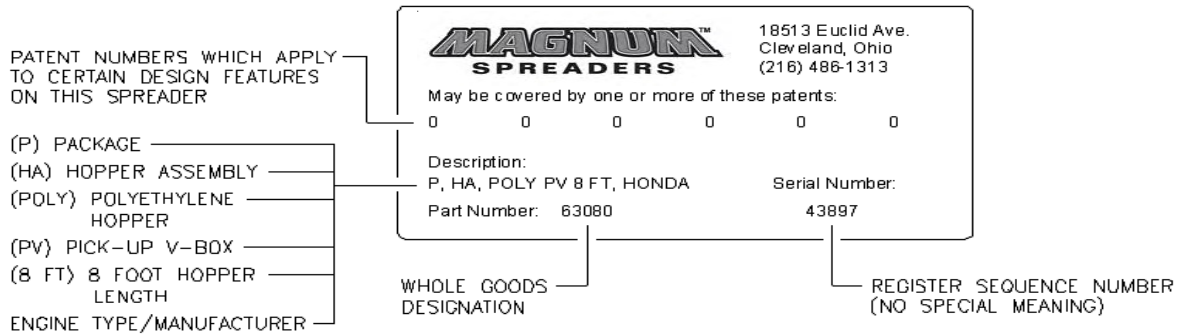

## TWO YEAR WARRANTY

### TWO YEAR WARRANTY

Magnum Spreader promises to the consumer to repair, or at our option to replace any part of this Magnum Spreader, accessory (other than noted below) except expendable parts such as pins, Spreader fins, and other normal wear items, which proves to be defective in workmanship or material under normal use for a period of two year's from the date of delivery to the original purchaser. During the two year's, Magnum Spreader will provide, through its Distributor / Sub-Distributor network, all labor or parts necessary to correct such defects free of charge. Faulty parts will be repaired or replaced by the Distributor / Sub-Distributor where that particular piece of equipment was purchased. Any cost incurred in returning the product to the Distributor / Sub-Distributor is the responsibility of the consumer.

### EXCLUSIONS

IN NO EVENT SHALL MAGNUM SPREADER BE LIABLE FOR SPECIAL, INCIDENTAL OR CONSEQUENTIAL DAMAGES OR FOR DAMAGES RESULTING FROM LACK OF NECESSARY MAINTENANCE, FROM MISUSE, ABUSE, ACTS OF GOD, ALTERATION OF ANY PRODUCT, OR FROM USE OF PARTS NOT SUPPLIED BY MAGNUM SPREADER. USE OF THE MAGNUM SPREADER FOR ANY PURPOSE OTHER THAN SPREADING MATERIALS AS INTENDED BY MAGNUM SPREADER, IS ONE EXAMPLE OF AN ABUSE AND MISUSE OF THE PRODUCT.

### WARRANTY SERVICE

In order to obtain service under this warranty, the consumer must return this product to the Distributor / Sub-Distributor from whom the product was purchased or to any authorized Magnum Spreader Distributor / Sub-Distributor, transportation and freight charges prepaid. Only Magnum Spreader Distributors / Sub-Distributors are authorized to perform the obligations under these warranties. For the address and telephone number of the Distributor / Sub-Distributor nearest you, check the telephone directory or you may write to the warrantor at the address below.

### GENERAL

It is the responsibility of the consumer to establish the warranty period by verifying the original delivery date. A bill of sale, canceled check or some other appropriate payment record may be kept for that purpose. For this warranty to be effective, the consumer must Register the product on-line at [www.magnumspreaders.com](http://www.magnumspreaders.com). No person is authorized to change this warranty or to create any warranty other than that set forth herein. This warranty gives you specific legal rights and you may also have other rights which vary from state to state.

**In order to validate this warranty, please go to our web site [www.magnumspreaders.com](http://www.magnumspreaders.com) to register your new Magnum Spreader.**

Magnum Spreader reserves the right, under its continuing product improvement program, to change construction or design details, specifications and prices without notice or without incurring any obligation.

Magnum Spreader  
18513 Euclid Ave. • Cleveland, Ohio 44112-1084  
Phone 485-1313 (Area Code 216)  
[www.magnumspreaders.com](http://www.magnumspreaders.com)

© 2007 Printed in the U.S.A.

# NOTES



MAGNUM SPREADERS  
18513 EUCLID AVE.  
CLEVELAND, OHIO 44112-1084

PHONE: (216)486-1313

website: [www.magnumspreaders.com](http://www.magnumspreaders.com)

**IMPORTANT  
INFORMATION  
ENCLOSED**