

PARTS & INSTALLATION INSTRUCTIONS MAGNUM S400P SPREADER

PARTS LIST

Item	Part No.	Qty.	Description	Item	Part No.	Qty.	Description
	36010	1	MINI SPREADER COMPLETE		36244	1	• Speed Control Assembly
	36386	1	• Spreader Assembly	21		1	•• Speed Control
1	36394	1	•• Hopper - Black	22		1	•• Mounting Bracket
2	36426	1	•• Hopper Cover - Black	23		2	•• Machine Screw, Rd Hd 8-32 x 1"
3	36384	1	•• Frame Weldment	24		4	•• Flatwasher #8
4	36428	1	•• Spinner Band Poly	25		2	•• Hex Nut 8-32
5	20049	1	•• Bolt H 3/8-16 x 1" Gr. 2		36404	1	• Reese Hitch Carton
6	20314	1	•• Locknut 3/8	26	36387	1	•• Reese Hitch Weld
7	20353	1	•• Flatwasher 3/8		36405	1	•• Hardware Bag
8	20006	4	•• Bolt H 1/4 - 20 x 1-1/4" Gr. 2	27	20097	4	••• Bolt H 1/2-13 x 2"
9	20351	4	•• Flatwasher 1/4	28	20307	4	••• Locknut 1/2-13
10	20312	4	•• Locknut 1/4	29	11101	1	••• Hinge Pin
	08729	1	Motor Kit - Service	30	22083	1	••• Linch pin
11	36402	1	••• Motor 12V D.C.		36403	1	• Carton - Miscellaneous Parts
	36401	1	••• Template	31	36240	1	•• Socket Assy. w/Mtg. Plate
	08730	1	••• Hardware Bag	32	36248	1	••• Dummy Plug
12	20029	4	•••• Bolt H 5/16 - 18 x 1-1/2" Gr.2			1	••• Machine Screw, Rd Hd 8-32
13	20313	4	•••• Washer 5/16			1	••• #8 Lockwasher
14	20352	4	•••• Locknut 5/16-18			1	••• Hex Nut 8-32
	36165	1	Spinner - Auger Assembly	33	36241	1	•• Plug Assembly
15	36151	1	••• Auger Weldment	34	36242	1	•• Wire, Red 222"
16	36152	1	••• Spinner Hub Weldment	35	36229	1	•• Wire, Blue 36"
17	21834	1	••• Set Screw 3/8-24 x 3/8 Cup Pt.	36	36247	1	•• Wire, Red 96"
	08757	1	Spinner Kit (Poly)				• Parts indented are included in carton, bag or assembly under which they are indented.
18	36414	1	••• Spinner Plate (Poly)				
19	20005	3	••• Bolt H 1/4 - 20 x 1" Gr. 2				
20	20303	3	••• Locknut 1/4 Esna				

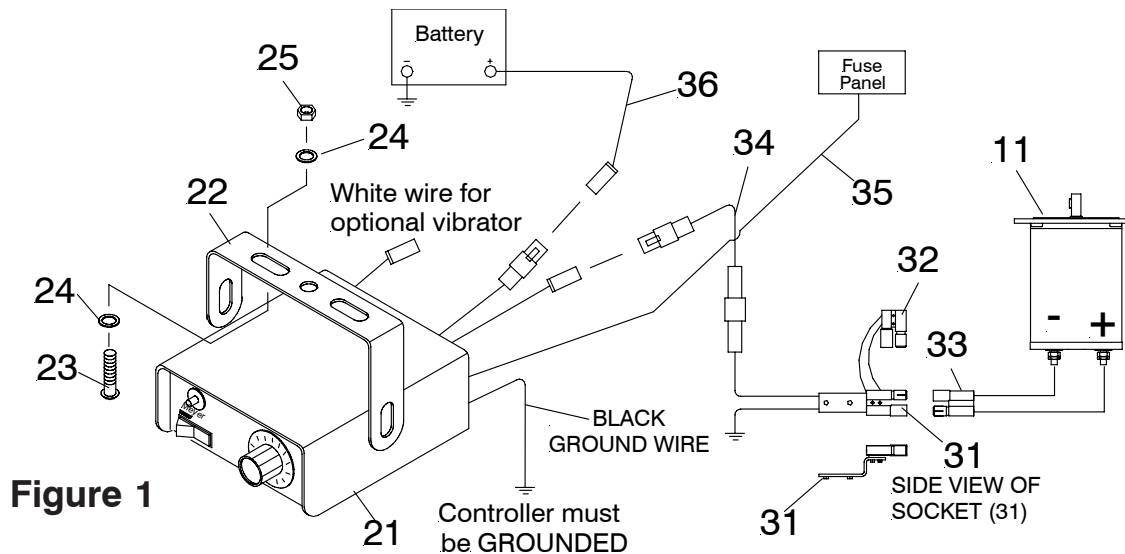

Magnum Spreader reserves the right, under its continuing product improvement program, to change construction or design details, specifications and prices without notice or without incurring any obligation.

Magnum Spreader
18513 Euclid Ave. • Cleveland, Ohio 44112-1084
Phone 486-1313 (Area Code 216)
www.magnumspreaders.com

GENERAL INFORMATION

CAUTION: Always disconnect battery before beginning installation.

Check contents against the parts list to determine all are correct and included, and also to familiarize yourself with them.

Locknuts are furnished. **DO NOT tighten bolts and nuts until** installation is complete (unless otherwise specified), then be sure to tighten all attaching parts per specified torque chart.

When ordering parts, furnish Part No., Name and Description.

INSTALLATION INSTRUCTIONS

- A. Assemble Reese Hitch (26) to Frame Weldment (3) using 1/2-13 x 2" Bolt (27) and 1/2-13 Locknut (28).
- B. Slide Spreader Assembly into Reese receiver hitch on vehicle and insert Hinge Pin (29) through corresponding hole on receiver and Hitch Weldment (26). Secure Hinge Pin with Linch Pin (30).
- C. Tighten all bolts to their required torque using the chart below.
- D. ELECTRICAL INSTALLATION. Refer to Figure 1.

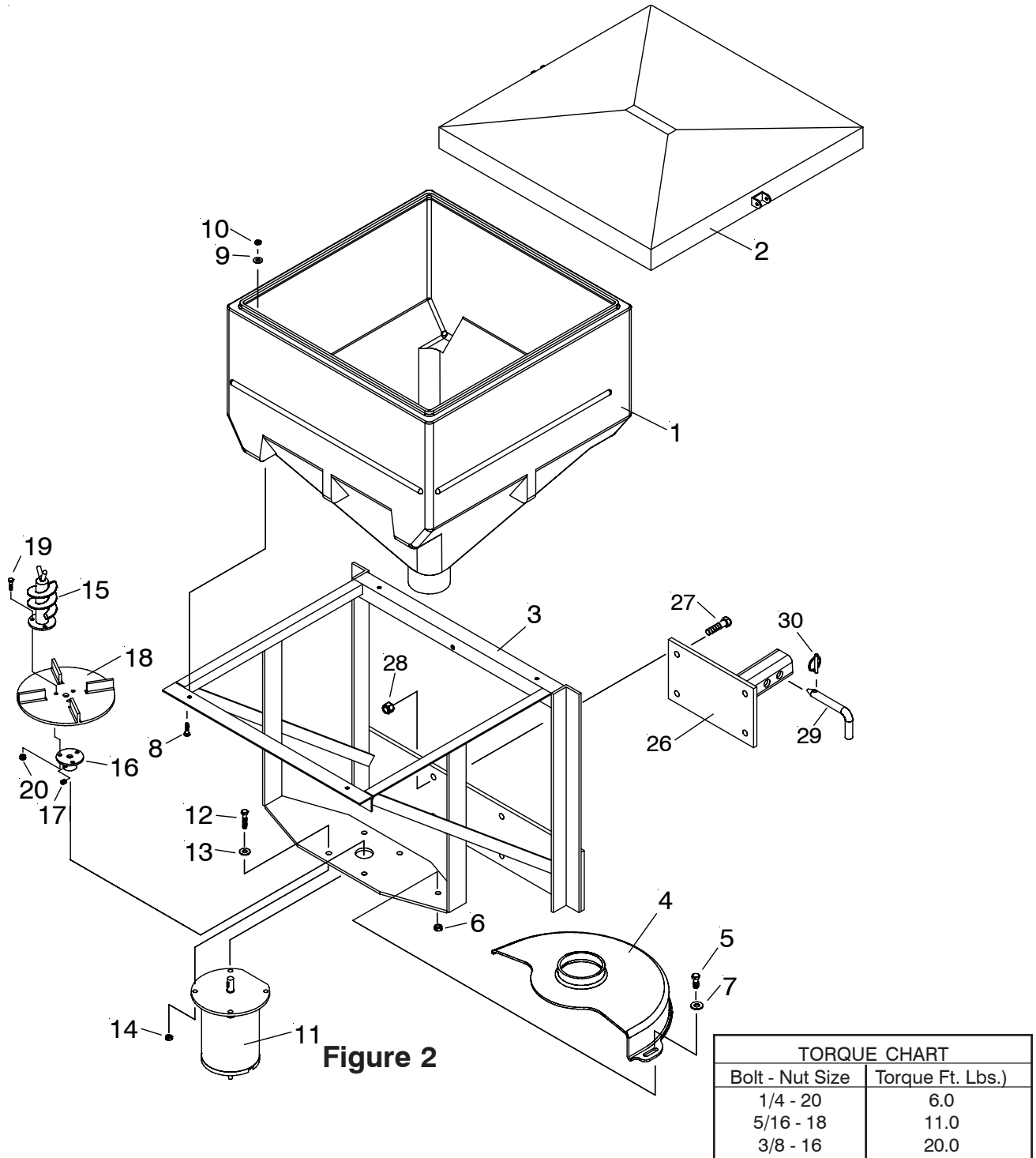

Magnum Spreader assumes no responsibility for installations not made in accordance with these instructions.

CAUTION

READ THIS! . . . Serious damage to Speed Control will result if the following precautions are not followed:

- 1] Do not install Speed Control until all other wiring is installed and Motor is test-run.
- 2] Be certain to connect red wire to (+) terminal of Motor. Connecting to (-) terminal will burn up Speed Control. Tape this (+) connection so it cannot accidentally be grounded.
- 3] After wires are in place, but before connecting Speed Control, connect a jumper wire from the red wire (34) to the red wire (36). The motor should run, indicating proper grounding and wire installation. Remove jumper wire.
- 4] After the Motor has successfully been test run, the Speed Control can be installed. Do not allow the red wire from the control to accidentally contact any grounded object, including the control case itself.

Failure to follow these precautions could cause the red (output) wire from the Speed Control to make contact with ground, causing the transistor to burn up. Any grounding or shorting of the red (output) wire which results in a burned transistor is **not** covered by warranty.

1. Choose a location for the speed control (21) that is convenient for the driver, noting whether mounting bracket will be attached to the top or bottom of speed control (21). Attach mounting bracket (22) to vehicle using Round Head Machine Screws (23), flatwashers (24), and hex nut (25). Make certain speed control (21) is grounded by attaching ground wire to a good vehicle ground.
2. Route the blue wire (35) from the speed control location to the vehicle fuse panel and attach to a switched terminal on the panel. This terminal must only be "hot" when the ignition switch is "on." **DO NOT** attach blue wire to speed control at this time.
3. Attach the eyelet end of the 96" red wire (36) to the positive terminal of the battery and route the plug end to the location of the speed control. **DO NOT attach to** speed control at this time.
4. Take the 222" red wire (34) and route the large rubber plug end to the rear of the truck, securely tying to vehicle frame. Be certain wire is clear of any sharp or moving objects or the vehicle's exhaust system.

CAUTION: Some vehicles are designed to operate with exhaust temperatures as high as 1800 F. This can easily damage any wires which are routed too closely or allowed to come in contact with any portion of the exhaust system. Be certain all wires are securely installed away from the exhaust system.

5. Attach the socket (31) to vehicle bumper or other solid mounting point using #8-32 x 1" screws, lockwashers and #8-32 locknuts. Be certain the motor leads will not be strained when the plug (33) is attached. Plug the 222" red wire (34) into the socket. Secure black wire from socket to a good grounding point on vehicle frame. Clean all rust or undercoating from this area.
6. Attach red wire from motor plug (33) to positive (+) terminal of motor. Tape this connection! Attach black wire to negative (-) terminal of motor. Push plug (33) into the socket (31). If spreader is removed, protect the socket (31) using dummy plug (32).
7. Perform the motor run test as described in paragraphs 3 and 4 of the "Caution" above. If the motor operates the 36" blue wire (35), 222" red wire (34) and 96" red wire (36) can be attached to their respective terminals on the speed control (21).

E. OPERATION OF MINI SPREADER

1. Fill Hopper with #1 Rock Salt or Calcium Chloride from bags. **Do not use bulk material.**

CAUTION: When filling Hopper, make certain there are no large objects contained in the material which could cause the Auger Spinner to bind and stop operation of the Spreader Motor. If this should happen, the circuit breaker becomes overloaded and will automatically break the circuit. Allow the Motor to cool and clear the Auger before pushing the reset button.

2. It is recommended to check for free rotation of the Auger Spinner before operating the Spreader due to possible buildup of material between the Auger and neck of the Hopper.

F. MAINTENANCE INSTRUCTIONS

Maintenance requirements for the Spreader during the winter season are relatively simple. Periodically inspect for loose bolts and nuts. Inspect for improper ground, broken wires, frayed or cracked wire insulation. Replace as necessary.

To keep maintenance to a minimum, the following cautions are suggested:

1. Do not attempt to clear Auger or Spinner or to perform any other maintenance or repair work on this Spreader unless the ignition switch is in the "OFF" position.
2. Salt must be loose and free from lumps and must be kept dry.
3. Empty Hopper after each use and hose the Spreader off.
4. When the Spreader is no longer being used, remove it from the tailgate. Remove any rust or corrosion from the metal parts, then prime the paint. It is recommended to detach 96" red wire (36) to prevent activation when not required. Store Spreader in a suitable location and attach dummy plug (32) to socket (31) to protect from corrosion.