

This Manual Must Be Read Before Operating The Equipment

# Owner / Operator's Manual

# SNOWEX<sup>®</sup>

## Spreaders for Snow & Ice Control

FOR MODELS

SR-110 Wireless Accurate Flow

SR-210 Wireless Multi-Purpose

**New Plug & Perform Technology  
Easy As 1-2-3 Installation**

**State of The Art Wireless Control  
Simple Push Button Operation**



**TRYNE<sup>®</sup>**  
INTERNATIONAL

Warren, Michigan 48089  
800-837-0159

CUSTOMER COPY

Protected by the following patents, #6,089,478, #6,088,865, #Des.425,915  
and other pending U.S. and foreign patent applications.

This Page Intentionally Left Blank

# Box Inventory



Model # SR-110 / SR-210

## SR-110 Box Contents



**G** SEE KEY FOB ILLUSTRATION TO THE RIGHT

ITEM	DESCRIPTION	QTY
A)	Spinner Drive Assembly	1
B)	Hopper	1
C)	Gate Deck/Hopper Support	1
D)	Hardware Pack	1
E)	Receiver Mount	1
F)	Hopper Support Tube	1
G)	Key Fob Transmitter	1



## SR-210 Box Contents



**G** SEE KEY FOB ILLUSTRATION TO THE RIGHT

ITEM	DESCRIPTION	QTY
A)	Spinner Drive Assembly	1
B)	Hopper	1
C)	Lower Hopper Support	1
D)	Hardware Pack	1
E)	Receiver Mount	1
F)	Hopper Support Tube	1
G)	Key Fob Transmitter	1



# STOP

1. Verify that your vehicle has a 7-way RV style trailer plug on vehicle.
2. If your vehicle is equipped with the proper plug continue to pages 5 and 6 for more specific information on your vehicle application.
3. Once you have activated your trailer plug and have verified power is present you can continue with the installation.
4. If you do not have power, consult your vehicle owner's manual trailering section for more information. If this does not resolve your problem, contact your nearest auto/truck dealer or trailer hitch installation center.
5. If your vehicle is not equipped with a 7-way trailer plug, you may purchase a custom harness from Trynex International. The part number is D-6068 and can be shipped direct to your location. Please contact Trynex International customer service at the number listed below.

**\*\* NOTE \*\* You Must Only Use 7-Way RV Style Plug For Power.**

# ATTENTION

Have a question or missing parts? Call the number below

**SnowEx Customer Service**  
**(800) 837-0159**

Monday through Friday 8:00 AM to 4:30 PM EST

# Vehicle Application List

Model # SR-110 / SR-210

MAKE	MODEL	YEAR	FACTORY PLUG AVAILABLE?	AFTERMARKET PLUG REQUIRED	FACTORY PLUG	AFTERMARKET PLUG
Chevrolet	Colorado	04 & Newer	Yes	NA	See Note *(1)	NA
Chevrolet	Blazer S-Series	05 & Prior	NA	Yes	NA	See Note **(2)
Chevrolet	Blazer K-Series	94 & Prior	NA	Yes	NA	See Note **(2)
Chevrolet	S-10	04 & Prior	NA	Yes	NA	See Note **(2)
Chevrolet	K-1500 - K-3500	99 & Prior	NA	Yes	NA	See Note **(2)
Chevrolet	Silverado	99 & Prior	Yes	NA	See Note *(1)	NA
Chevrolet	Suburban	02 & Prior	NA	Yes	NA	See Note **(2)
Chevrolet	Suburban	02 & Newer	Yes	NA	See Note *(1)	NA
Chevrolet	Express	02 & Newer	Yes	NA	See Note *(1)	NA
Chevrolet	Tahoe	02 & Newer	Yes	NA	See Note *(1)	NA
Chevrolet	Trailblazer	02 & Current	Yes	NA	See Note *(1)	NA
Chevrolet	G-Series Van	02 & Prior	NA	Yes	NA	See Note **(2)
Dodge	Dakota	02 & Prior	NA	Yes	NA	See Note **(2)
Dodge	Dakota	02 & Newer	Yes	NA	Nothing Required	NA
Dodge	Durango	02 & Prior	NA	Yes	NA	See Note **(2)
Dodge	Durango	02 & Newer	Yes	NA	Nothing Required	NA
Dodge	Nitro	07 & Newer	NA	Yes	NA	See Note **(2)
Dodge	Van B-Series	02 & Prior	NA	Yes	NA	See Note **(2)
Dodge	Ram Van	02 & Newer	Yes	NA	Nothing Required	NA
Dodge	Ram Pick-Up	02 & Previous	NA	Yes	NA	See Note **(2)
Dodge	Ram Pick-Up	02 & Newer	Yes	NA	Nothing Required	NA
Ford	Escape	01 & Newer	NA	Yes	NA	See Note **(2)
Ford	Expedition	97 & Newer	Yes	NA	See Note **(3)	NA
Ford	Excursion	00 & Newer	Yes	NA	See Note **(3)	NA
Ford	Explorer	02 & Prior	NA	Yes	NA	See Note **(2)
Ford	Explorer	02 & Newer	Yes	NA	See Note **(3)	NA
Ford	F-150 Pick-up	02 & Prior	NA	Yes	NA	See Note **(2)
Ford	F-150 Pick-Up	02 & Newer	Yes	NA	See Note **(3)	NA
Ford	F-250 & F-350	02 & Prior	NA	Yes	NA	See Note **(2)
Ford	F-250 & F-350	02 & Newer	Yes	NA	See Note **(3)	NA
GMC	Canyon	04 & Newer	Yes	NA	See Note *(1)	NA
GMC	S-15 Sonoma	04 & Prior	NA	Yes	NA	See Note **(2)
GMC	Blazer S-Series	05 & Prior	NA	Yes	NA	See Note **(2)
GMC	Blazer K-Series	94 & Prior	NA	Yes	NA	See Note **(2)
GMC	Envoy	02 & Current	Yes	NA	See Note *(1)	NA
GMC	K-1500 - K-3500	99 & Prior	NA	Yes	NA	See Note **(2)
GMC	Sierra	99 - Current	Yes	NA	See Note *(1)	NA
GMC	Yukon	02 & Prior	NA	Yes	NA	See Note **(2)

**Factory Plug Note \*(1)** Locate red wire under power distribution box and hook the eyelet to the AUX stud on front of the power distribution box. Verify that the 30 AMP mega fuse is installed for the trailer fuse slot. Refer to the vehicle owner's manual for fuse location.

**Aftermarket Plug Note \*\*(2)** If vehicle is equipped with 7-way plug, verify pin #4 has a 12 volt power source and pin #1 has a common ground source. See included diagram. Consult your local trailer hitch installer for more information. If vehicle is not equipped with a 7-way plug, please contact your nearest hitch dealer.

**Factory Plug Note \*\*(3)** Ford vehicles with factory 7-Wire plug, install provided 30 AMP fuse into the trailer to battery charge circuit. Install provided 30 AMP relay into the trailer tow battery charge circuit. Refer to the owner's manual for fuse and relay information.

# Vehicle Application List Continued



## Model # SR-110 / SR-210

MAKE	MODEL	YEAR	FACTORY PLUG AVAILABLE?	AFTERMARKET PLUG REQUIRED	FACTORY PLUG	AFTERMARKET PLUG
GMC	Yukon	02 & Current	Yes	NA	See Note *(1) Pg 19	NA
GMC	Savana	02 & Current	Yes	NA	See Note *(1) Pg 19	NA
GMC	G-Series Van	02 & Current	NA	Yes	NA	See Note **(2) Pg 19
Hummer	H2	03 & Current	Yes	NA	NA	See Note ****(4)
Hummer	H2 Sut	06 - Current	Yes	NA	NA	See Note ****(4)
Hummer	H3	06 - Current	Yes	NA	Nothing Required	NA
Hummer	H3 T	06 - Current	Yes	NA	Nothing Required	NA
Jeep	Cherokee	All	NA	Yes	NA	See Note *(1) Pg 19
Jeep	Grand Cherokee	04 & Prior	NA	Yes	NA	See Note *(1) Pg19
Jeep	Grand Cherokee	04 & Newer	Yes	NA	Nothing Required	NA
Jeep	Commander	06 - Current	Yes	NA	Nothing Required	NA
Jeep	Compass	All	NA	Yes	NA	See Note *(1) Pg 19
Jeep	Liberty	All	NA	Yes	NA	See Note *(1) Pg 19
Jeep	Patriot	All	NA	Yes	NA	See Note *(1) Pg 19
Jeep	Wrangler	All	NA	Yes	NA	See Note *(1) Pg 19
Isuzu	Rodeo	All	NA	Yes	NA	See Note *(1) Pg 19
Isuzu	Pick-Up	All	NA	Yes	NA	See Note **(2) Pg 19
Honda	Ridgeline	All	NA	Yes	NA	See Note **(2) Pg 19
Toyota	Full Size Pick-Up	02 - Current	Yes	NA	See Note ***** (5)	NA
Toyota	Tacoma	02 - Current	Yes	NA	See Note ***** (5)	NA
Toyota	4-Runner	02 - Current	Yes	NA	See Note ***** (5)	NA
Toyota	Highlander	02 - Current	Yes	NA	See Note ***** (5)	NA
Toyota	Land Cruiser	00 - Current	Yes	NA	See Note ***** (5)	NA
Toyota	Tundra	00 - Current	Yes	NA	See Note ***** (5)	NA
Nissan	Pick-Up	All	NA	Yes	NA	See Note **(2) Pg 19
Nissan	Titan	04 - Current	Yes	NA	See Note ***** (5)	NA
Nissan	Frontier	All	NA	Yes	NA	See Note **(2) Pg 19
Nissan	Pathfinder	All	NA	Yes	NA	See Note **(2) Pg 19
Nissan	X-Treme	All	NA	Yes	NA	See Note **(2) Pg 19
Nissan	Armada	All	NA	Yes	NA	See Note **(2) Pg 19
Nissan	Raider	All	NA	Yes	NA	See Note **(2) Pg 19
Mercury	Mountainer	02 - Current	Yes	NA	See Note *** (3) Pg 19	NA

**Factory Plug Note \*\*\*\* (4)** Hummer H2 and H3 SUT with factory 7-wire plug. Remove power distribution box cover and remove RED B+ plastic plug and install supplied 30 AMP fuse into this slot. Refer to owner's manual for further instruction.

**Aftermarket Plug Note \*\*\*\*\* (5)** Full size trucks with factory installed 7-wire plug. Refer to owner's manual for hook-up of trailer battery charge circuit. Hook-up to verify that the factory plug (see included diagram) pin#4 has a 12 volt power source and pin #1 has a common ground source.

# Assembly Instructions

Model # SR-110 (refer to diagram on page 1-10)

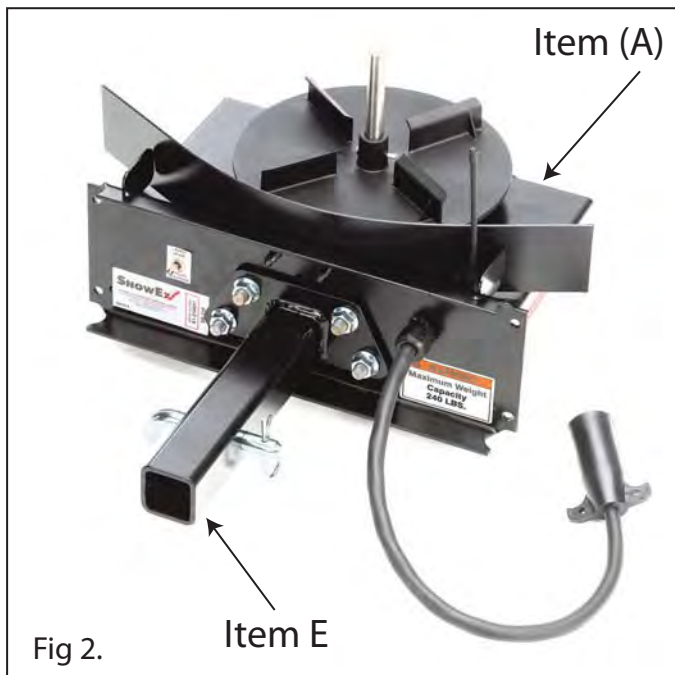
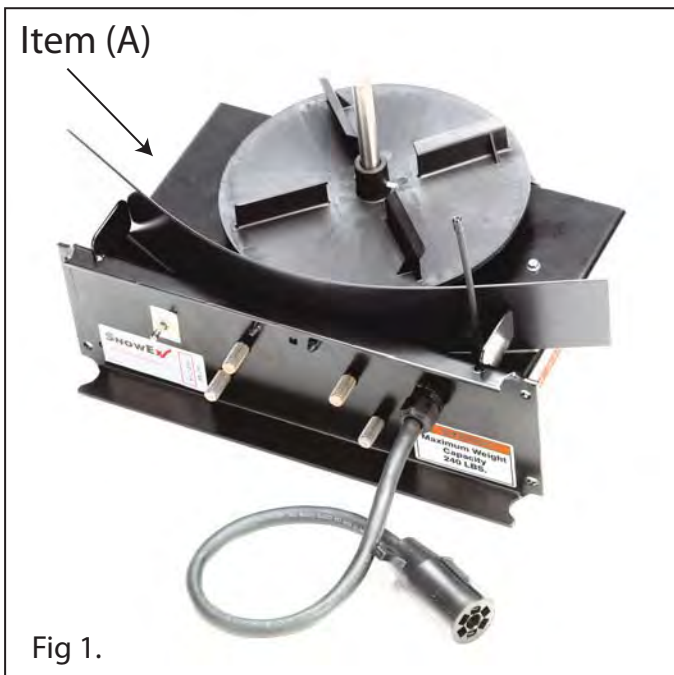

**Step 1:** Place item (A) on level working surface as shown in figure 1.

**Step 2:** Mount item (E) to item (A) as shown in figure 2. Using (4) 1/2" lock nuts and tighten securely in place with 3/4" socket or wrench to 75 Foot pounds.

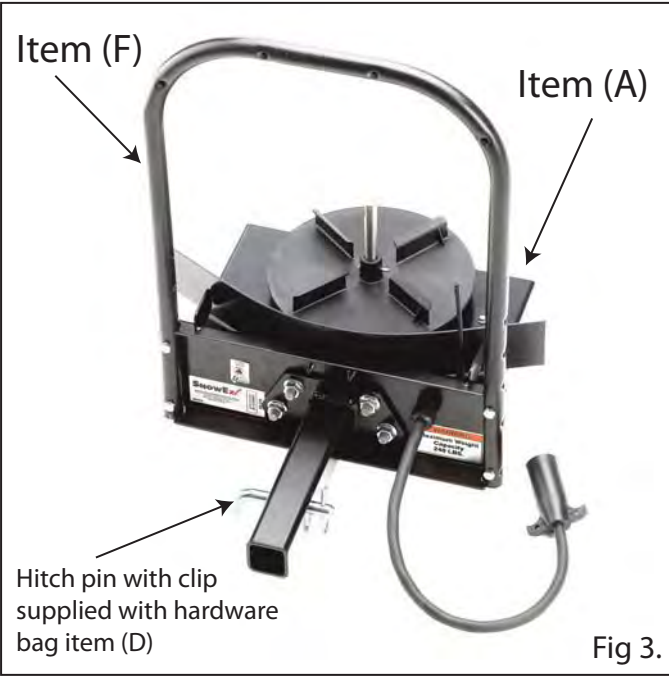

**Step 3:** Mount item (F) to item (A) as shown in figure 3. Using (4) 5/16" hex bolts and (4) 5/16" lock nuts and tighten securely in place with 1/2" socket or wrench to 18 foot pounds.

# Assembly Instructions

Model # SR-110 (refer to diagram on page 1-10)

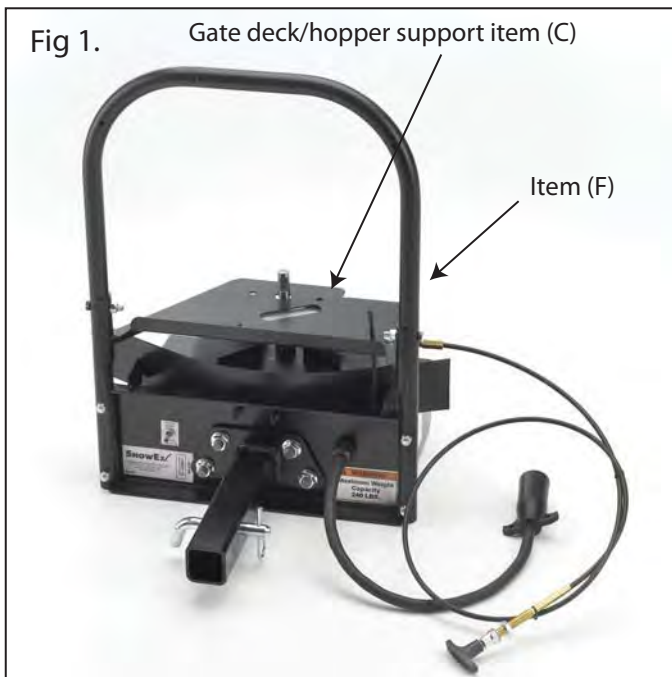

**Step 4:** Install item (C) to item (F) as shown in figure 1. Using (2) 5/16" hex bolts and (2) 5/16" lock nuts supplied in hardware bag item (D). Tighten securely in place with 1/2" socket or wrench to 18 foot pounds.



**Step 5:** Mount item (B) to item (F) as shown in figure 2. Using (4) 5/16" hex bolts, (4) fender washers and (4) 5/16" lock nuts supplied in hardware bag item (D). Fender washers must be installed inside the hopper to provide proper support as shown in figure 2. Tighten securely in place with 1/2" socket or wrench to 18 foot pounds.

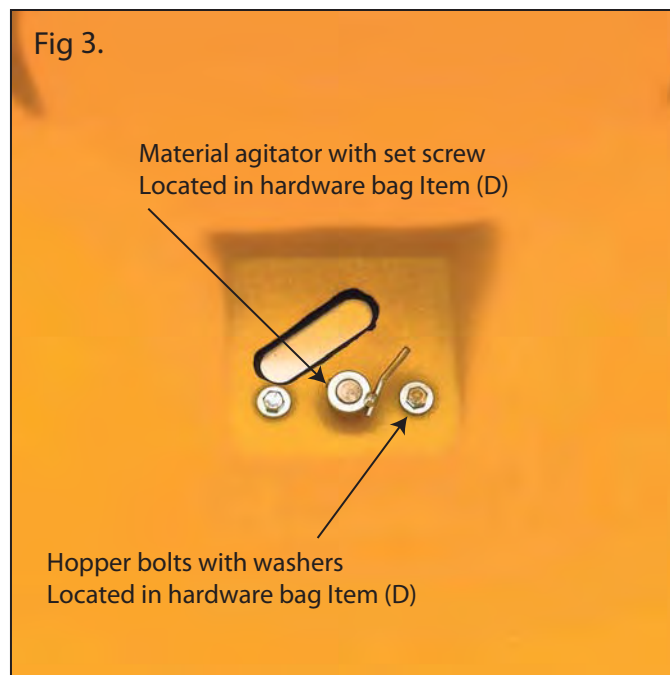

**Step 6:** Mount item (B) to item (C) using (2) 5/6" hex bolts and (2) washers supplied in hardware bag item (D). Tighten securely in place with 1/2" socket or wrench to 18 foot pounds. Mount material agitator by placing it on the upper part of the transmission shaft. Line up set screw with upper flat and tighten with a 5/32" allen wrench. Be sure to put agitation finger so that it is facing upward as shown in fig 3.



# Assembly Instructions

Model # SR-110 (refer to diagram on page 1-10)

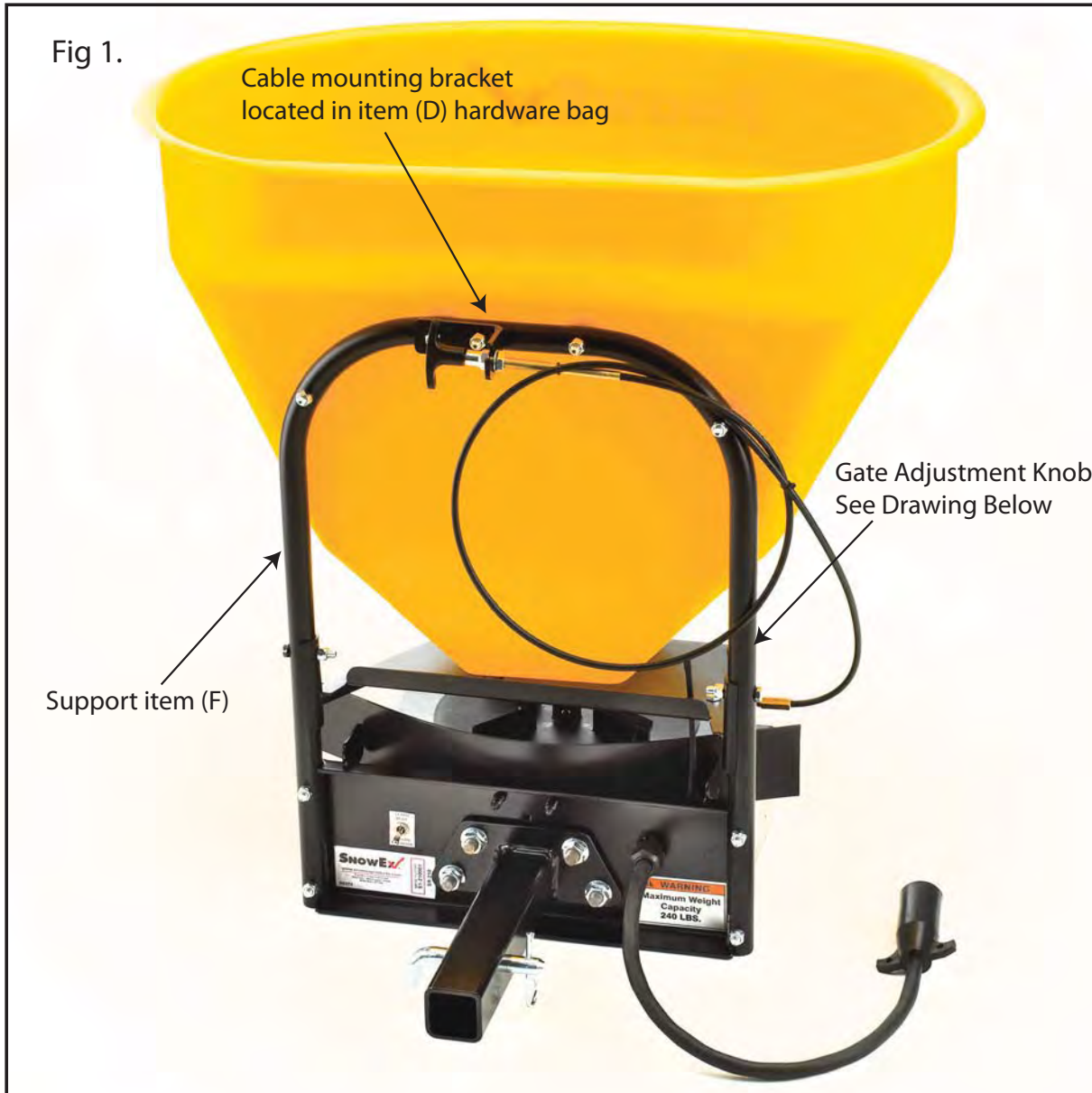

**Step 7:** Mount control bracket to item (F) using existing hopper mounting hardware as shown in figure 1. Cable should be looped as shown in figure 1 if mounted to this way. When mounting in a remote location, be sure to leave a large radius in cable so it will not bind or kink. You can also mount the control bracket on a vehicle using (2) 5/16" hex bolts and (2) 5/16" lock nuts supplied in item (D) hardware bag.

**Step 8:** Material flow can be adjusted with moving the locking knob forward or backward to increase or decrease the amount of material to be applied to an area.

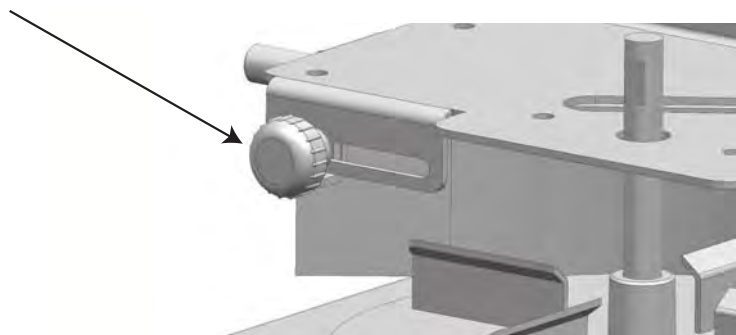

# Parts Breakdown

Model #SR-110

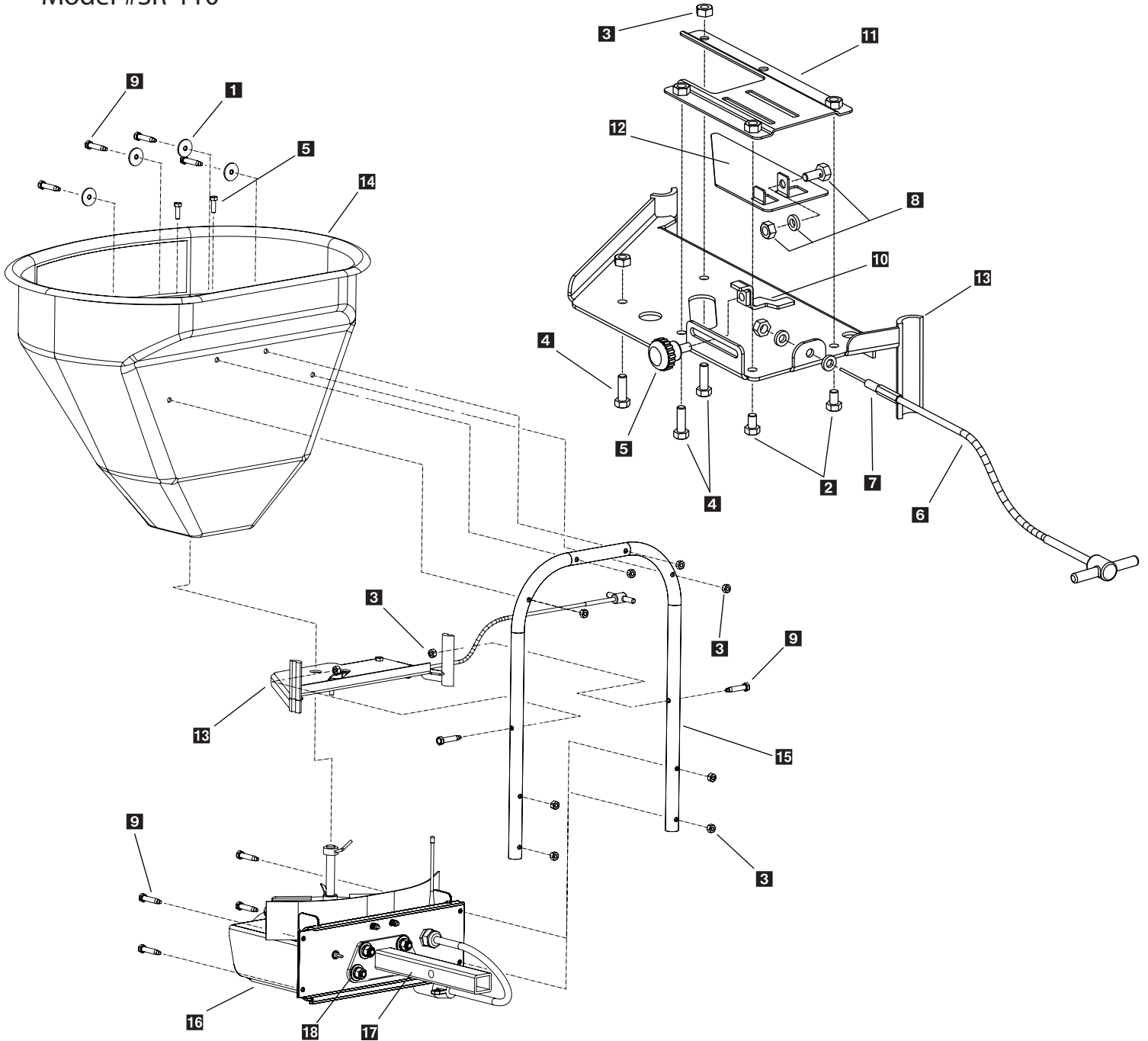

Key	Part No.	Description	Qty.	Key	Part No.	Description	Qty.
1	D 6081	5/16" Fender Washer	4	11	D 6704	Seeder Gate Track	1
2	D 6133	5/16" - 18 x 1/2" Hex Bolt	2	12	D 6705	Seeder Gate Slide	1
3	D 6138	5/16" Locknut	14	13	D 6077	Seeder 400 Gate Deck	1
4	D 6166	5/16" - 18 x 1" Hex Bolt	3	14	D 6753	2.7 Cu/Ft Seeder Hopper Yellow	1
5	D 6302	Gate Knob	1	15	D 6065	Hopper Tube Support	1
6	D 6072	T-Handle Cable - 5'	1	16	D 6063	Transmission Weldment	1
7	D 6305	Bulkhead Cable Fitting Assembly	1	17	D 6062	Light Duty Receiver Hitch	1
8	D 6308	5/16" - 16 x 3/4" Bolt Assy. w/Hole	1	18	D 5535	1/2" Serrated Flange Nut	4
9	D 6462	5/16" - 18 x 1-3/4" HHCS	12				
10	D 6703	Gate Indicator / Stop	1				

# Complete Drive Assembly Parts Breakdown

Model # SR-110

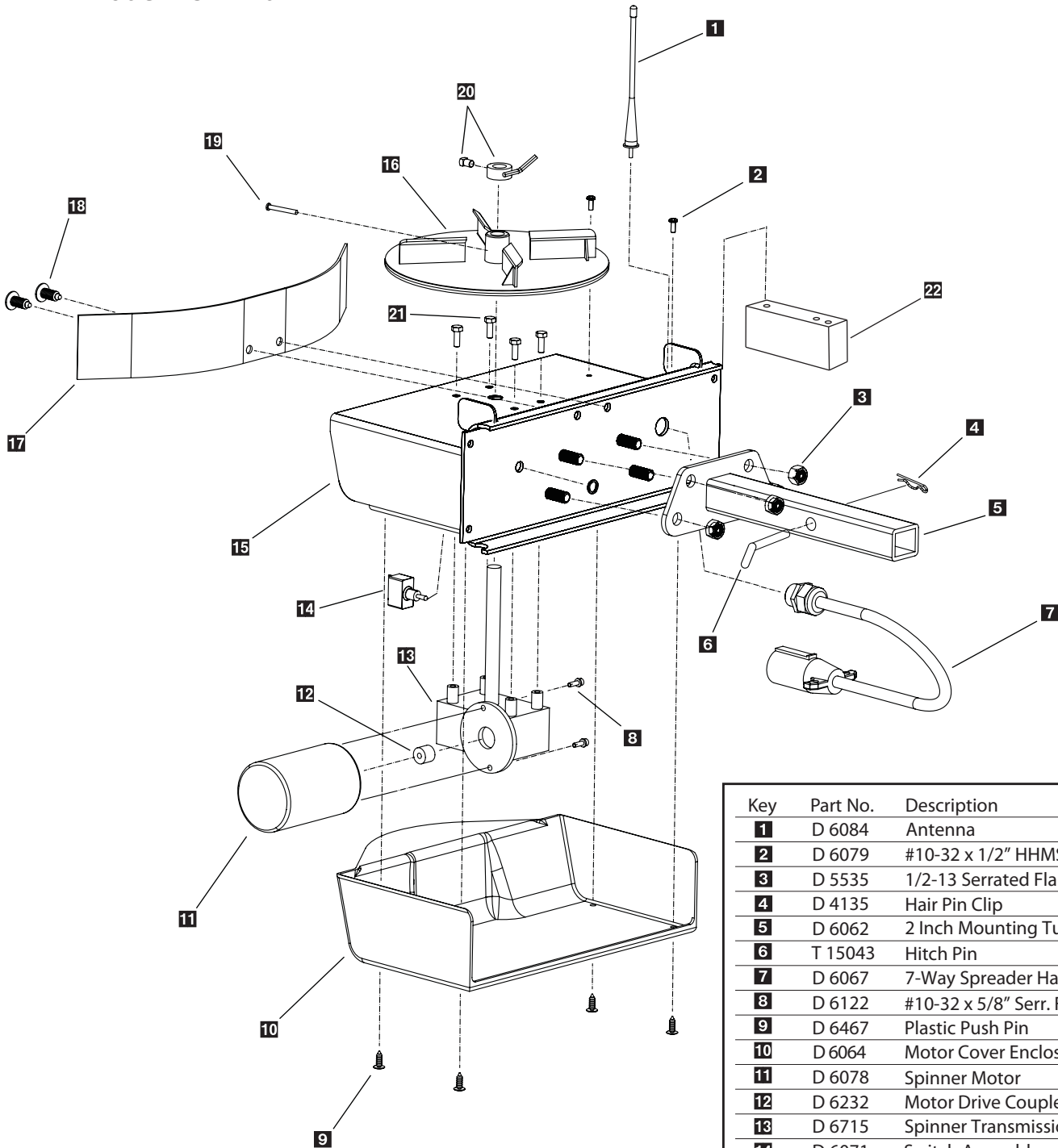

A 4005 Complete Drive Assembly

Key	Part No.	Description	Qty.
1	D 6084	Antenna	1
2	D 6079	#10-32 x 1/2" HHMS W/Washer	2
3	D 5535	1/2-13 Serrated Flange Nut	4
4	D 4135	Hair Pin Clip	1
5	D 6062	2 Inch Mounting Tube Weldment	1
6	T 15043	Hitch Pin	1
7	D 6067	7-Way Spreader Harness	1
8	D 6122	#10-32 x 5/8" Serr. Flng.Bolt	2
9	D 6467	Plastic Push Pin	4
10	D 6064	Motor Cover Enclosure	1
11	D 6078	Spinner Motor	1
12	D 6232	Motor Drive Coupler	1
13	D 6715	Spinner Transmission	1
14	D 6071	Switch Assembly	1
15	D 6063	Spinner Drive Enclosure	1
16	D 6750	Plastic Spinner	1
17	D 6110	Material Deflector	1
18	D 6463	Plastic Push Pin	2
19	D 6398	Spinner Detent Pin	1
20	D 6405	Material Agitator	1
21	D 6131	1/4-20 x 1/2" Hex Bolt SS	4
22	D 6061	Wireless Receiver	1

# Assembly Instructions

Model # SR-210 (refer to diagram on page 1-15)



**Step 1:** Place item (A) on level working surface as shown in figure 1.

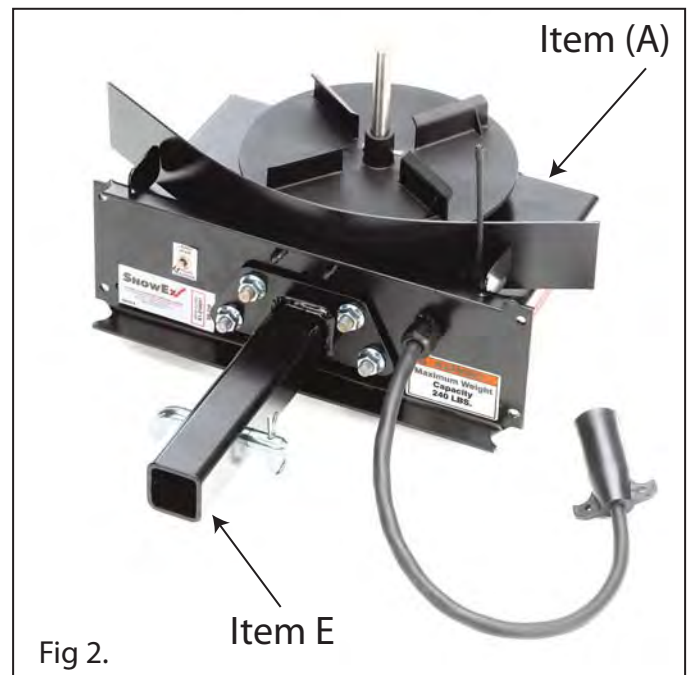

**Step 2:** Mount item (E) to item (A) as shown in figure 2. Using (4) 1/2" lock nuts and tighten securely in place with 3/4" socket or wrench to 75 foot pounds.

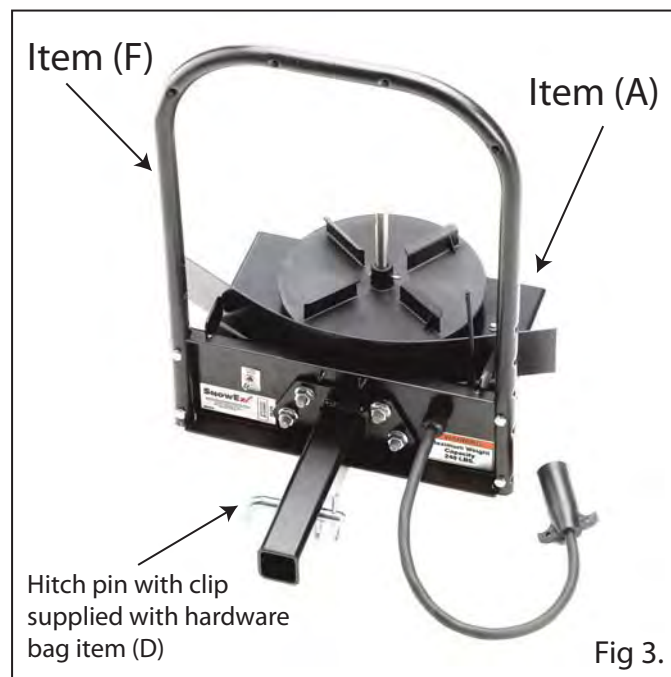

**Step 3:** Mount item (F) to item (A) as shown in figure 3. Using (4) 5/16" hex bolts and (4) 5/16" lock nuts and tighten securely in place with 1/2" socket to 18 foot pounds.

# Assembly Instructions

Model # SR-210 (refer to diagram on page 1-15)

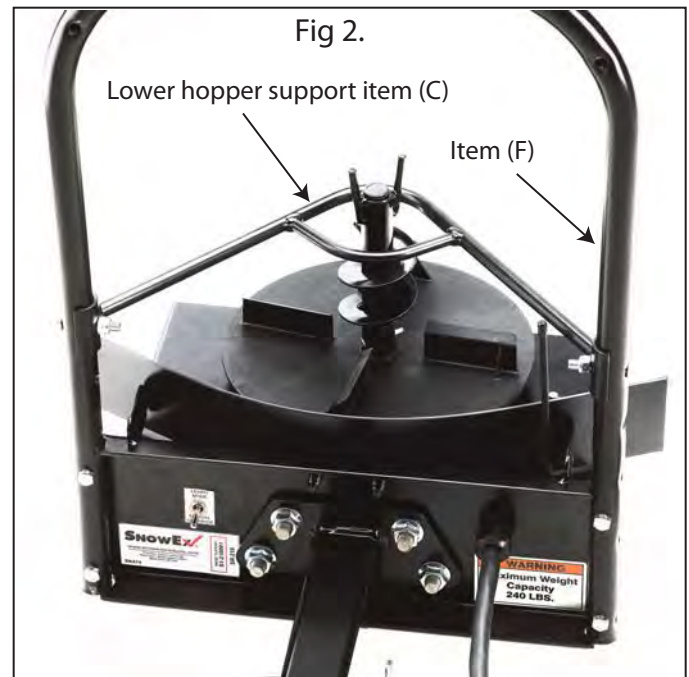

**Step 4:** Place auger on transmission shaft so that the set screw hole lines up with the upper flat on shaft as shown in figure 1. Thread set screw into hole until it makes contact with the flat on the transmission shaft. Make sure the set screw is set to the upper part of the flat. Complete tightening the set screw into place with a 5/32" allen wrench.

**Step 5:** Mount item (C) to item (F) as shown in figure 2. Using (2) 5/16" hex bolts and (2) 5/16" lock nuts supplied in hardware bag item (D). Tighten securely in place with 1/2" socket or wrench to 18 foot pounds.

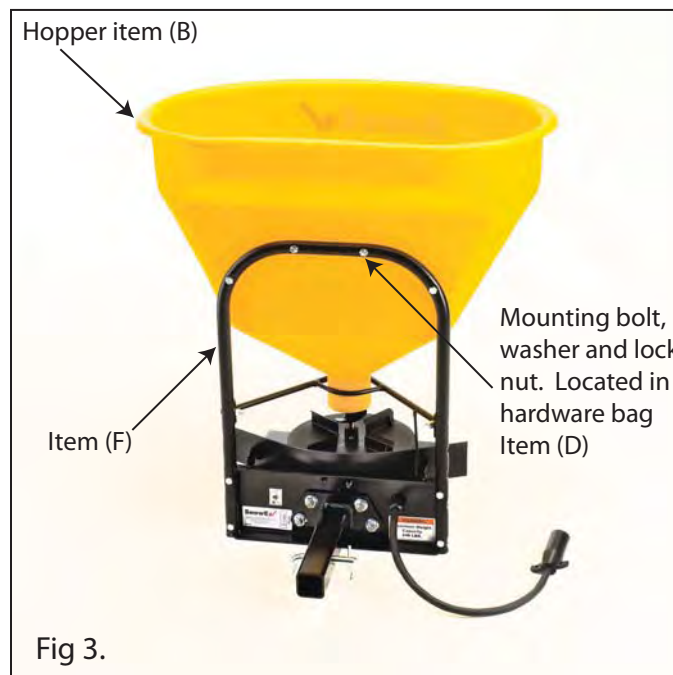

**Step 6:** Mount item (B) to item (F) using (4) 5/16" hex bolts, fender washers and 5/16" lock nuts supplied in hardware bag item (D). Fender washers must be installed on **inside** of hopper to provide proper support. Tighten securely in place with 1/2" socket or wrench to 18 foot pounds. See page 1-7 figure 2 for more information on how to properly install hopper.

# Assembly Instructions

Model # SR-210 (refer to diagram on page 1-15)



# Parts Breakdown

Model # SR-210

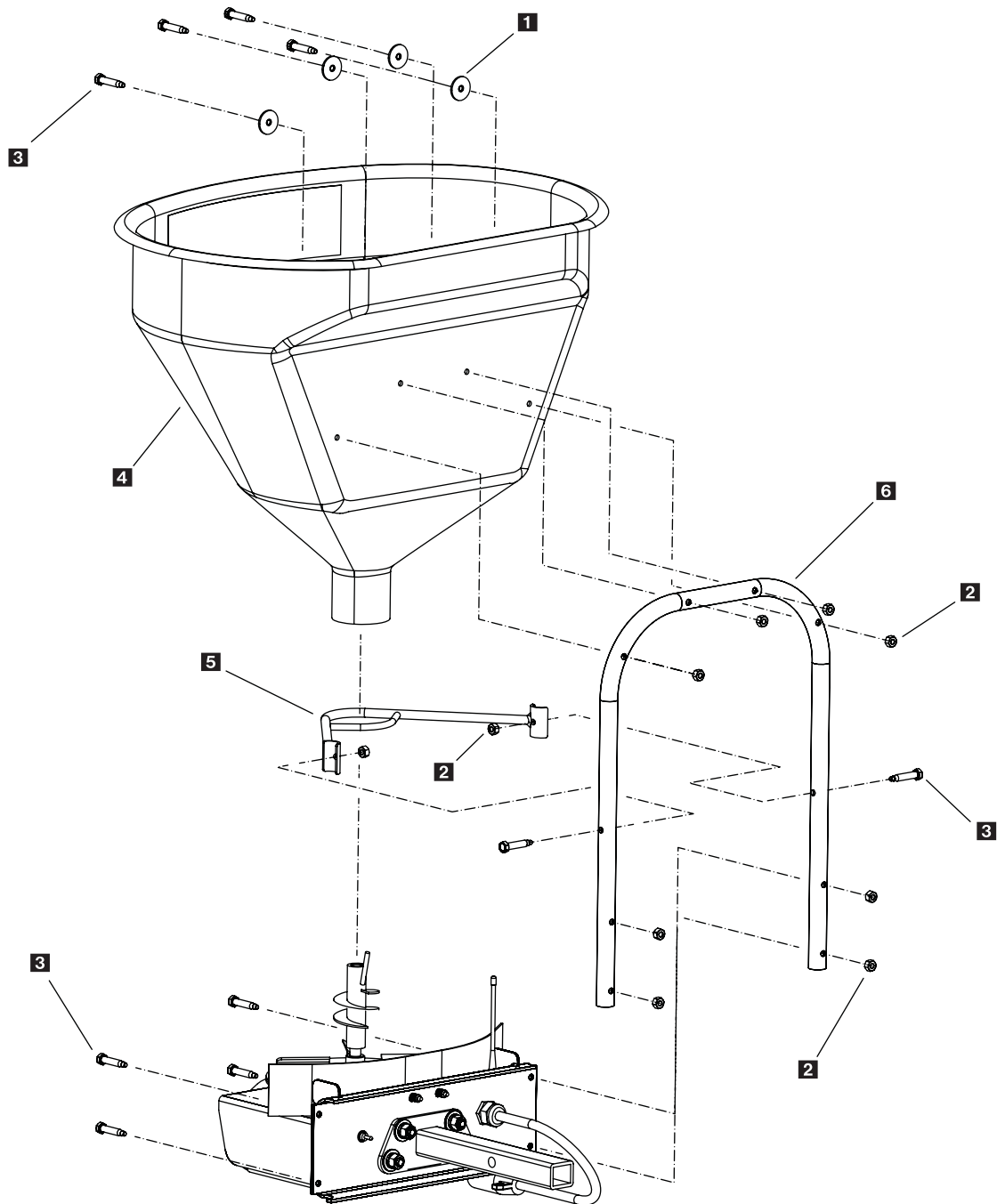

Key	Part No.	Description	Qty.
<b>1</b>	D 6081	3/8" Fender Washer	4
<b>2</b>	D 6138	5/16" Locknut	10
<b>3</b>	D 6462	5/16" - 18 x 1-3/4" HHCS	10
<b>4</b>	D 6754	2.7 cu/ft Salter Hopper Yellow	1
<b>5</b>	D 6066	Hopper Throat Support	1
<b>6</b>	D 6065	Main Tube Support	1

# Complete Drive Assembly Parts Breakdown

Model # SR-210

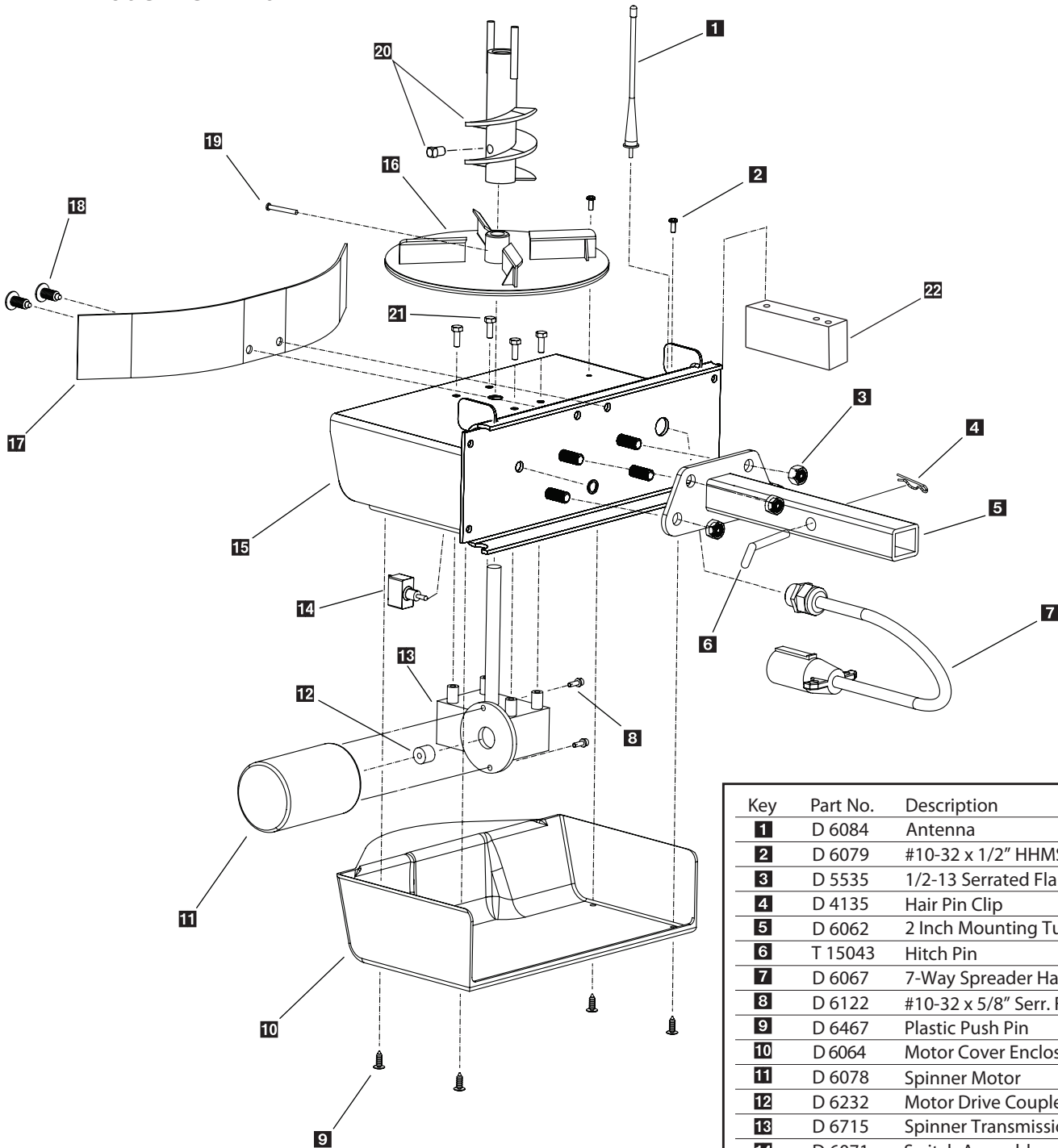

A 4005 Complete Drive Assembly

Key	Part No.	Description	Qty.
1	D 6084	Antenna	1
2	D 6079	#10-32 x 1/2" HHMS W/Washer	2
3	D 5535	1/2-13 Serrated Flange Nut	4
4	D 4135	Hair Pin Clip	1
5	D 6062	2 Inch Mounting Tube Weldment	1
6	T 15043	Hitch Pin	1
7	D 6067	7-Way Spreader Harness	1
8	D 6122	#10-32 x 5/8" Serr. Flng.Bolt	2
9	D 6467	Plastic Push Pin	4
10	D 6064	Motor Cover Enclosure	1
11	D 6078	Spinner Motor	1
12	D 6232	Motor Drive Coupler	1
13	D 6715	Spinner Transmission	1
14	D 6071	Switch Assembly	1
15	D 6063	Spinner Drive Enclosure	1
16	D 6750	Plastic Spinner	1
17	D 6110	Material Deflector	1
18	D 6463	Plastic Push Pin	2
19	D 6398	Spinner Detent Pin	1
20	D 6075	Material Auger	1
21	D 6131	1/4-20 x 1/2" Hex Bolt SS	4
22	D 6061	Wireless Receiver	1



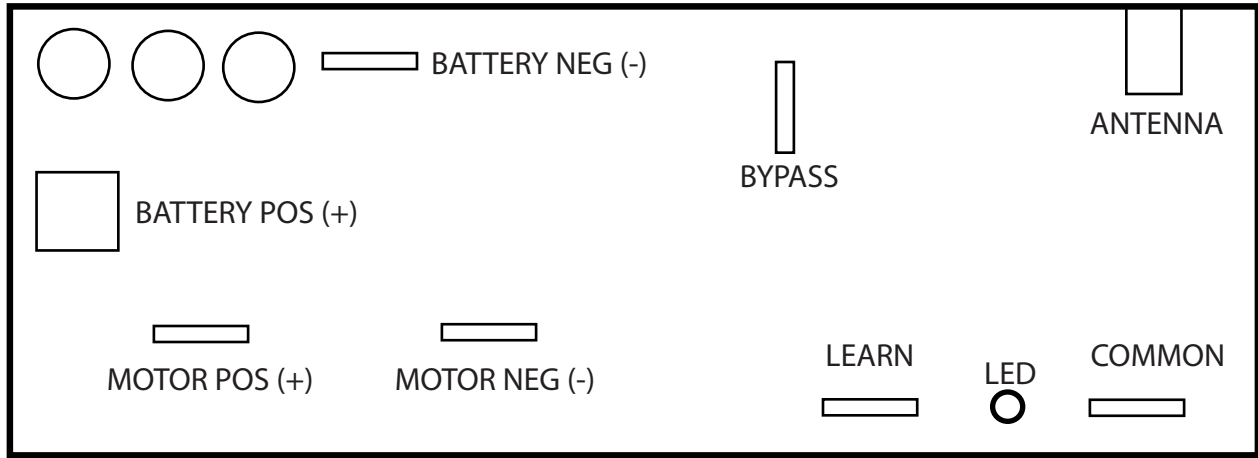

Wireless Receiver Connections

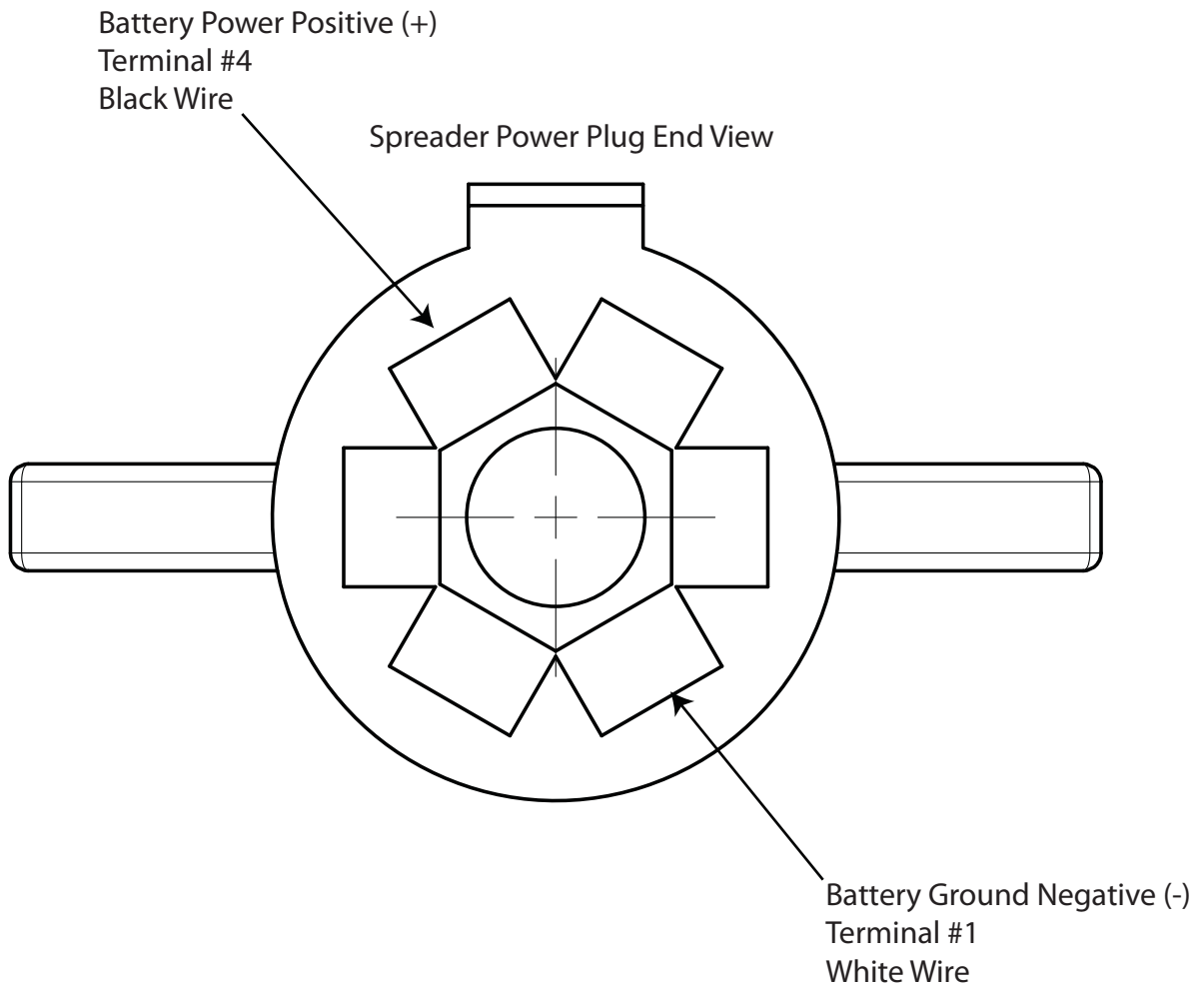

# Key Fob Programming / Bypass Function

Model # SR-110 / SR-210

## Programming a New Key Fob Transmitter

Apply power to the spreader unit (Spreader plugged into the 7 -way connector and typically vehicle running.) Press the Learn / Bypass switch to the Learn position for 2 seconds and release. Move clear of the spreader and keep hands and feet away from the spreader. Press and hold the 50% button on the key fob transmitter to be learned until the spreader starts. (It may take up to 30 seconds for the key fob to be learned.) Release the 50% button and press the Off button on the keyfob. The keyfob has now been programmed.

If the spreader does not start within 30 seconds then release the 50% button on the key fob transmitter, wait for at least 20 seconds, and try the process again. Make sure power is actually arriving at the spreader.

## Erasing All Learned Remotes

Apply power to the spreader unit (Spreader plugged into the 7 -way connector and typically vehicle running.) Press the Learn / Bypass switch to the learn position for 15 seconds and release. The spreader has erased ALL learned remotes. A key fob transmitter will have to be learned before the spreader will operate.

## Placing the Spreader in Bypass

Remove power from the spreader unit and place the Learn / Bypass switch in the Bypass position. When power is next applied to the spreader unit, it will operate in Bypass mode and start at the 100% speed. The remote key fob will be locked-out. Moving the Learn / Bypass switch out of the Bypass position will stop the spreader if it is operating in Bypass mode. However, the remote key fob will remain locked-out until power is removed from the spreader unit. Bypass mode can only be activated by a power-off to power-on transition while the Learn / Bypass switch is in the Bypass position. The bypass position is ignored when the spreader unit is operating in the normal, key fob remote, mode.



Learning/Bypass Mode  
Switch Operation

Learning Mode (Up)  
Momentary.

Normal Operation (Center)  
On.

Bypass Mode (Down)  
On.

# General Information

## Model # SR-110 / SR-210

CONGRATULATIONS!

The spreader you have purchased is an example of snow and ice control technology at its finest! Your spreader's self-contained design is a trademark of all Snowex products. Here's why...

**SIMPLICITY:** Fewer moving parts manufactured of higher quality means minimal maintenance for your SnowEx spreader.

**RELIABILITY:** High impact linear low density polyethylene hopper, state-of-the-art electronic wireless speed control, custom engineered powder coated frame, maximum torque 12 volt motor coupled to a custom engineered transmission found only on SnowEx products.

**VERSATILITY:** Multi-use capabilities allows spreading of a variety of materials for snow and ice control.

**WARRANTY:** Best in the industry, hands down! 2 years standard and now 5 year extended (optional).

The benefits you are about to recognize are that of time, money and effort. We welcome you to the world of Snowex Performance.

Please fill out the warranty card with all the necessary information to validate it. This will also give us a record so that any safety or service information can be communicated to you. **You can also log onto our website and fill out your warranty form at ([www.snowexproducts.com](http://www.snowexproducts.com)).** Go to the warranty section of the web page and follow prompts to the proper form. Upon completion, we will send a free how to guide on how to earn more cash in the snow and ice control industry.

## Registration

Record the following information in this manual for quick reference. You can also log onto our website and fill out your warranty form at ([www.snowexproducts.com](http://www.snowexproducts.com)). Go to the warranty section of the web page and follow prompts to the proper form. Upon completion, we will send a free "How To" guide on how to earn more cash in the snow and ice control industry.

Spreader Model Number \_\_\_\_\_

Spreader Serial Number \_\_\_\_\_ Controller Serial Number \_\_\_\_\_

Date of Purchase \_\_\_\_\_

Dealer Where Purchased \_\_\_\_\_

When ordering parts, the above information is necessary. This will help to insure that you receive the correct parts. Below is a diagram of the ID tag. This tag on the spreader is located on the frame



# Safety Introduction

Model # SR-110 / SR-210

This manual has been designed for your help. It will assist you and instruct you on the proper set-up, installation and use of this spreader. Refer to the table of contents for an outline of this manual.

We require that you read and understand the contents of this manual completely (especially all safety information) before attempting any procedure contained herein. Extra copies of Owner/Operator Manuals can be purchased at your Snowex Dealer.



THIS SIGN SHOULD ALERT YOU:

The Society of Automotive Engineers has adopted this SAFETY ALERT SYMBOL to pinpoint characteristics that, if NOT carefully followed, can create a safety hazard. When you see this symbol in this manual or on the machine itself, BE ALERT! Your personal safety and the safety of others is involved.

Defined below are the SAFETY ALERT messages and how they will appear in this manual:



**DANGER**

(RED)

Information that, if not carefully followed, can cause death!



**WARNING**

(ORANGE)

Information that, if not carefully followed, can cause serious personal injury or death!



**CAUTION**

(YELLOW)

Information that, if not carefully followed, can cause minor injury or damage to equipment.



Before attempting any procedure in this book, these safety instructions must be read and understood by all workers who have any part in the preparation or use of this equipment.

For your safety, warning and information decals have been placed on this product to remind the operator of safety precautions. If anything happens to mark or destroy the decals, please request new ones from Snowex.



Remember, most accidents are preventable and caused by human error. Exercising of care and precautions must be observed to prevent the possibility of injury to operator or others!



Never operate equipment when under the influence of alcohol, drugs, or medication that might alter your judgment and/or reaction time.



Before working with the spreader, secure all loose fitting clothing and unrestrained hair.



Always wear safety glasses with side shields when working metal against metal. Failure to do this could result in serious injury to the eyes.



Never allow children to operate or climb on equipment.  
Never weld or grind on equipment without having a fire extinguisher available.  
Always check areas to be spread to be sure no hazardous conditions or substances are in the area.  
Always inspect unit for defects: broken, worn or bent parts, weakened areas on spreader or mount.



Always shut off vehicle and power source before attempting to attach or detach or service spreader unit. Be sure vehicle/power source is properly braked or chocked.



Always make sure personnel are clear of areas of danger when using equipment.



Always keep hands, feet, and clothing away from power-driven parts.



Remember, it is the owner's responsibility to communicate information on safe usage and proper maintenance of all equipment.



**WARNING**

Never exceed 45 m.p.h. when loaded spreader is attached to vehicle. Braking distances may be increased and handling characteristics may be impaired at speeds above 45 m.p.h.



**CAUTION**

Never use wet materials, or materials with foreign debris with any of these spreaders. These units are designed to handle dry, clean, free-flowing material. Note: Can not spread water softener salt.



**CAUTION**

Never leave material in hopper for long periods of time. Be aware that all ice melters are hygroscopic and will attract atmospheric moisture and harden up.



**WARNING**

Always inspect pins and latches whenever attaching or detaching spreader, and before traveling.



**WARNING**

Inspect the unit periodically for defects. Parts that are broken, missing, or worn out must be replaced immediately. The unit or any part of it can not be altered without prior written permission from the manufacturer.



**CAUTION**

If your vehicle is equipped with a tow package, please refer to enclosed charts and diagram for proper installation. Failure to follow these instructions will seriously damage the unit and or the vehicle. Once installed and plugged in verify that the unit works before loading with material. This will make it easier to diagnose any problems that may occur.



**CAUTION**

Any wiring should be done by a certified professional to prevent any damage to the vehicle's wiring or electronic systems.

Examples of warning decals to indicate operational awareness.



D 6544



D 6548



D 6335

# Wireless General Information



## Model # SR-110 / SR-210

This device complies with Part 15 of the FCC rules.

Operation of this device is subject to the following two conditions.

- (1) This device may not cause harmful interference, and
- (2) This device must accept any interference received, including interference that may cause undesired operation.

This equipment has been tested and found to comply with the limits for a Class B digital device, pursuant to Part 15 of the FCC Rules. These limits are designed to provide reasonable protection against harmful interference in a residential installation. This equipment generates, uses and can radiate radio frequency energy and, if not installed and used in accordance with the instructions, may cause harmful interference to radio communications. However, there is no guarantee that interference will not occur in a particular installation. If this equipment does cause harmful interference to radio or television reception, which can be determined by turning the equipment off and on, the user is encouraged to try to correct the interference by one or more of the following measures:

Reorient or relocate the receiving antenna.

Increase the separation between the equipment and receiver.

Connect the equipment into an outlet on a circuit different from that to which the receiver is connected.

Consult the dealer or an experienced radio/TV technician for help.

This equipment has been certified to comply with the limits for a Class B computing device, pursuant to FCC Rules. In order to maintain compliance with FCC regulations, shielded cables must be used with this equipment. Operation with non-approved equipment or unshielded cables is likely to result in interference to radio or TV reception. The user is cautioned that changes and modifications made to the equipment without the approval of the manufacturer could void the user's authority to operate this equipment.

The actual size decals below must be located on the spreader to comply with FCC Rules.

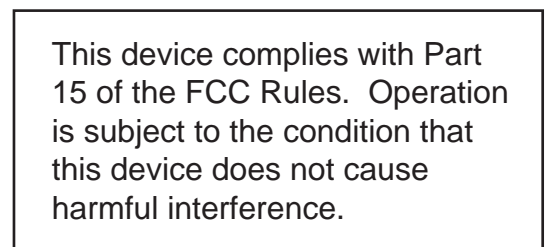
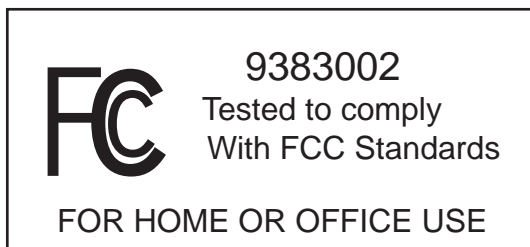

# Spreader Maintenance and Operation



## Model # SR-110 / SR-210

- WARNING – When servicing is necessary, perform it in a protected area. Do not use power tools in rain or snow because of danger of electrical shock or injury. Keep area well lit. Use proper tools. Keep the area of service clean to help avoid accidents.
- WARNING – Disconnect electricity to spreader before servicing.
- CAUTION – There are no serviceable parts in the motor/transmission assembly. Any attempt to service will void warranty.
- CAUTION – When replacing parts, use only original manufacturer's parts. Failure to do so will void warranty.
- Use dielectric grease on all electrical connections to prevent corrosion at the beginning and end of the season and each time power plugs are disconnected.
- Wash unit after each use to prevent material build-up and corrosion.
- CAUTION – When pressure washing motor enclosure area, stay at least 36" away from motor enclosure and antenna.
- Paint or oil all bare metal surfaces at the end of the season.
- If motor cover is removed for any reason, use silicone sealant to ensure weather proofing of enclosure.
- After first use, tighten all nuts and bolts on spreader and mount.
- Apply a small amount of oil on gate cable to prevent corrosion and maximize the cable life.
- CAUTION – Spinner motor is not designed for continuous duty. Allow motor to cool between long cycle times.

### PREPARATION

CAUTION –Sweep area clear of foreign objects or obstacles that could cause personal injury. Keep other persons, children, or animals out of the area to be spread.

### SPREADER LOADING

WARNING –Do not overload vehicle. Use chart below to calculate weight of material. Weights of material are an average for dry materials.

<u>Material</u>	<u>Weight Per Cubic Ft.</u>
Rock Salt	35-40 lbs.

- Be sure to comply with manufacturer's maximum gross vehicle weight ratings.
- Warning– Never leave materials in hopper for long periods of time as salt is hygroscopic and will attract atmospheric moisture and harden up.

**SR 110 - Use Only Ice Melter Type Materials For Spreading.**

**SR 210 - Use Only Bag Type Salt Materials For Spreading.**

### SPREADING TIPS

- Never exceed 10 m.p.h. when spreading.
- For a wider pass, increase spinner speed.
- Never operate spreader near pedestrians.
- Spread ice melters with the storm to prevent unmanageable levels of ice.
- Calculate spread pattern when near vegetation.



# Troubleshooting

Model # SR-110 / SR-210

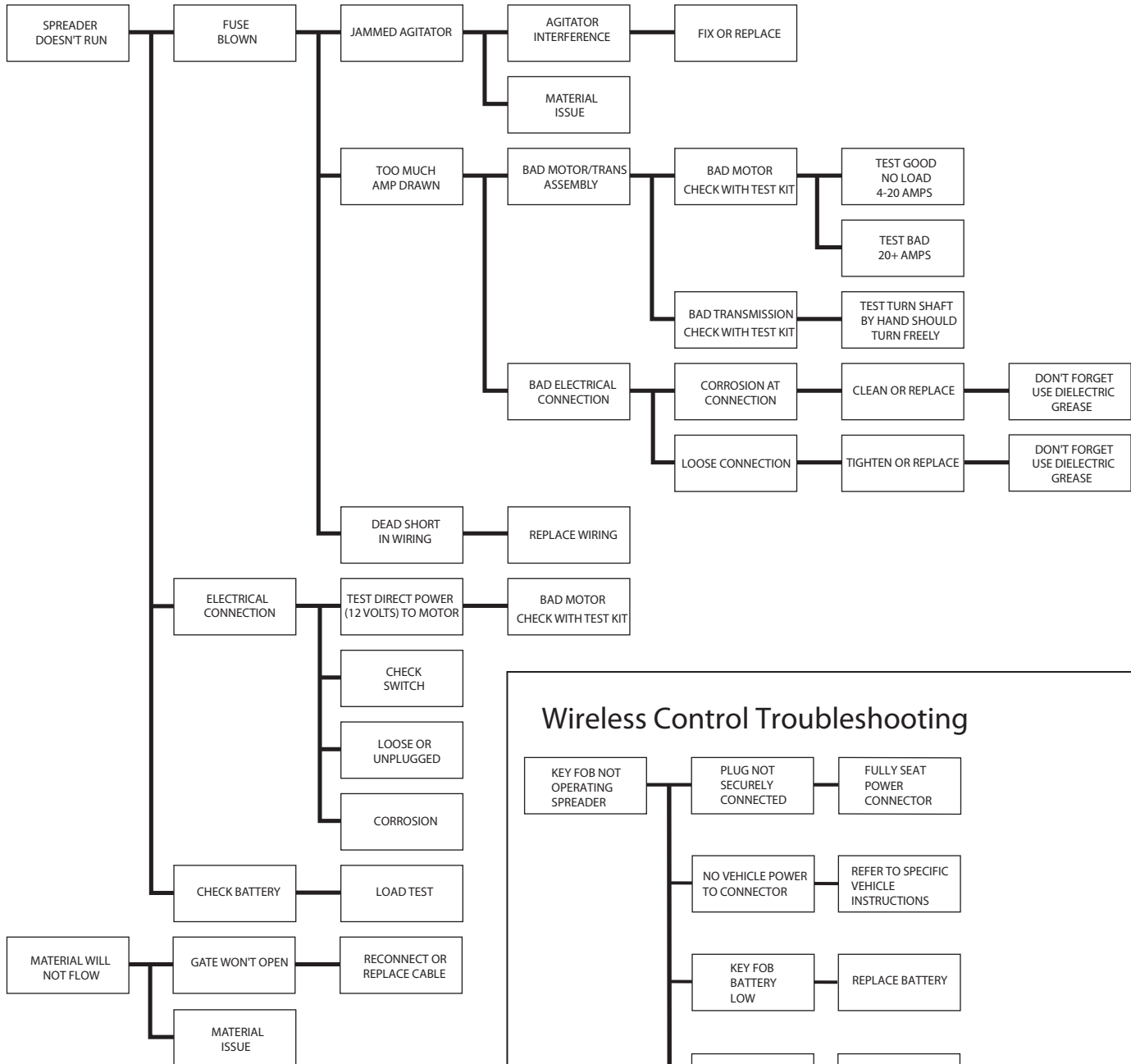

## Wireless Control Troubleshooting

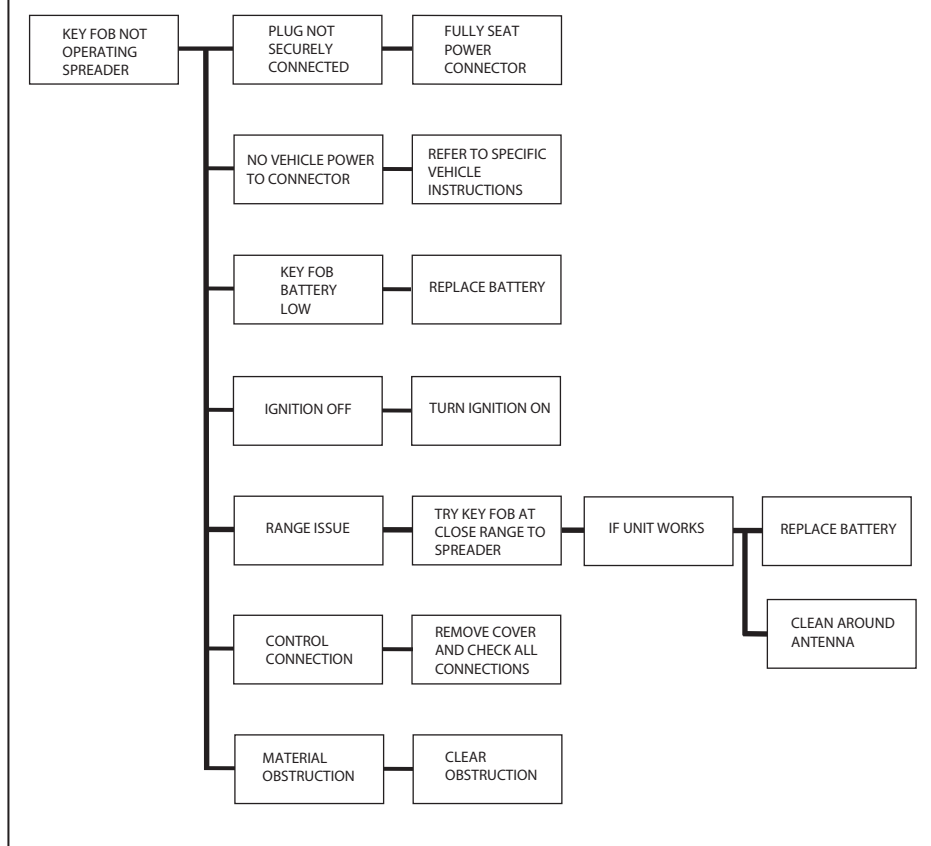

# Available Optional Accessories

Model # SR-110 / SR-210

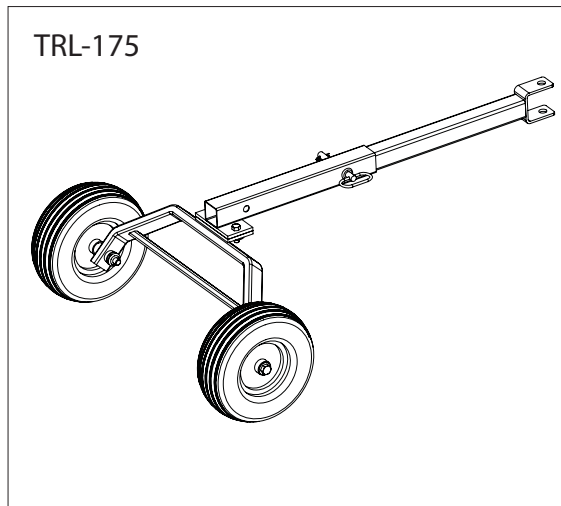

TRAILER MOUNT

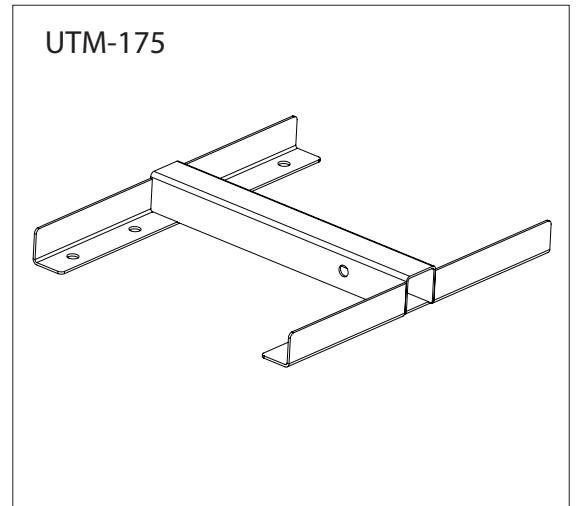

UTILITY MOUNT

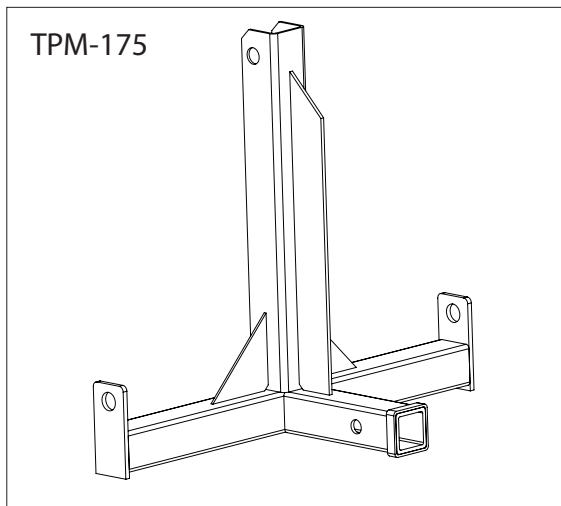

THREE POINT MOUNT

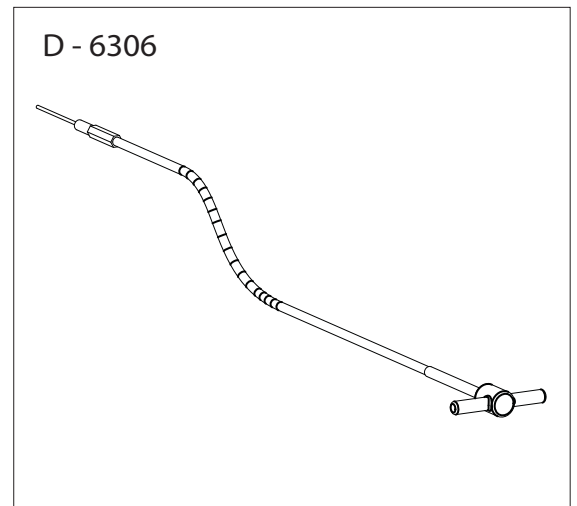

20' CABLE EXTENSION

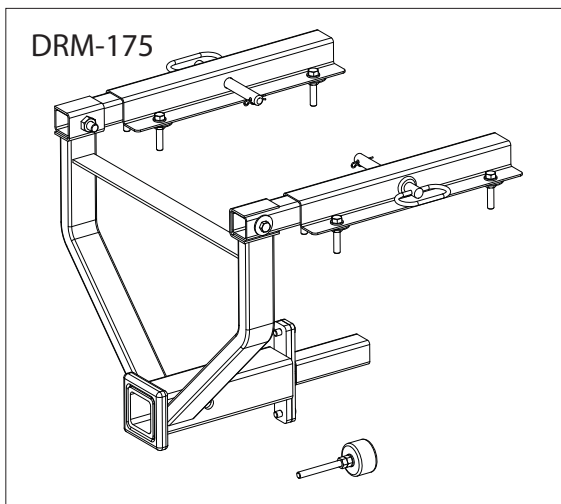

DROP UTILITY MOUNT

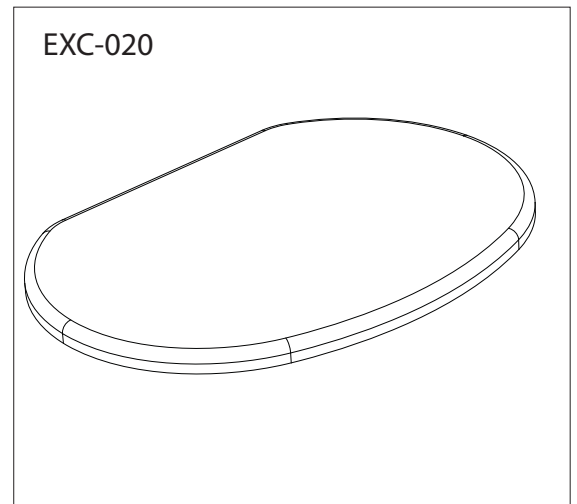

HOPPER COVER

## Limited Warranty

Snowex products are warranted for a period of two years from the date of purchase against defects in material or workmanship under normal use and service, subject to limitations detailed below. Warranty period of two years begins on the date of purchase by the original retail user.

The WARRANTY REGISTRATION CARD must be returned to the manufacturer for this warranty to become effective. This warranty applies to the original retail purchaser only. This warranty does not cover damages caused by improper installation, misuse, lack of proper maintenance, alterations or repairs made by anyone other than authorized Snowex dealers or Snowex personnel. Due to the corrosive properties of the materials dispensed by spreaders, Trynex does not warrant against damage caused by corrosion. Warranty claims by the user must be made to the dealer from where the product was purchased, unless otherwise authorized by Snowex. Snowex reserves the right to determine if any part is defective and to repair or replace such parts as it elects. This warranty does not cover shipping costs of defective parts to or from the dealer.

### LIMITATION OF LIABILITY

Neither Snowex, nor any company affiliated with it, makes any warranties, representations for promise as to the performance or quality other than what is herein contained. The liability of Snowex to the purchaser for damages arising out of the manufacture, sale, delivery, use or resale of this spreader shall be limited to and shall not exceed the costs of repair or replacement of defective parts. Snowex shall not be liable for loss of use, inconvenience or any other incidental, indirect or consequential damages, so the above limitations on incidental or consequential damages may not apply to you.

NO DEALER HAS AUTHORITY TO MAKE ANY REPRESENTATION OR PROMISE ON BEHALF OF SNOWEX, OR TO ALTER OR MODIFY THE TERMS OR LIMITATIONS OF THIS WARRANTY IN ANY WAY.

# **TRYNEX**<sup>®</sup>

**INTERNATIONAL**

**800-837-0159**



**Don't Forget To Visit Our Website !!**  
**[www.snowexproducts.com](http://www.snowexproducts.com)**  
**to register your product and receive**  
**a FREE "How To" spreading guide.**  
**[www.storksplows.com](http://www.storksplows.com)**