

# GLAND NUT RAM SEAL KITS

## SEAL AND O-RING INSTALLATION

1. Lubricate seals and O-rings with hydraulic fluid.
2. Install seals and O-rings in the **exact** orientation shown.

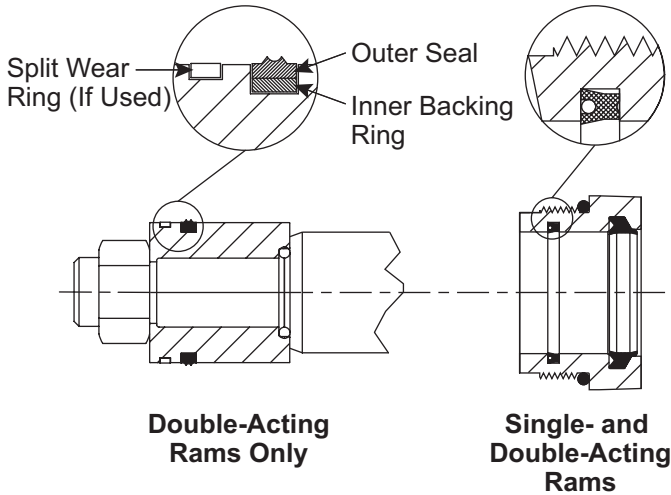

3. **For single-acting rams:** Slide gland nut over split bearing end of rod to prevent damaging seals.

**For double-acting rams:** Slide gland nut over threaded end of rod to prevent damaging seals.

4. **For double-acting rams only:** Install piston in the orientation shown. Tighten piston locknut to 100-120 ft-lb for 1-3/4" and 2" rams and 35-40 ft-lb for 1-1/2" rams.
5. Carefully reassemble the ram.
6. Insert a feeler gauge (0.015" for 1" single-acting and 1-1/2" double acting rams, 0.012" for all other rams) between the front surface of the cylinder tube face and the hex of the gland nut. Tighten gland nut until it is snug against the feeler gauge.
7. Remove the feeler gauge, and tighten gland nut an additional **1/4 turn**. This adjustment procedure will provide a torque of 120-150 ft-lb for 1" single-acting and 1-1/2" double acting rams and 150-180 ft-lb for all other rams.

# GLAND NUT RAM SEAL KITS

---

## HYDRAULIC HOSE AND FITTING INSTALLATION

---

**NOTE: Overtightening JIC hose fitting ends will result in a fractured fitting.**

---

**DO NOT** use any type of sealant or tape on the fittings or hoses. This could damage product. Always use two wrenches to ensure proper tightening of fittings and hoses.

### SAE O-Ring Style

#### Fittings

1. Turn jam nut on fitting as far back as possible.
2. Lubricate O-ring with clean hydraulic fluid.
3. Screw fitting into port by hand until the washer contacts port face and shoulder of the jam nut threads.
4. Unscrew fitting to proper position no more than one full turn.
5. Using two wrenches, hold fitting body in position and tighten jam nut until the washer again contacts port face, then tighten an additional 1/8 to 1/4 turn to lock fitting in place. Final torque on the jam nut should be approximately 20 ft-lb.

#### Hydraulic Hoses

1. Screw flare nut onto fitting flare and hand tighten.
2. Align hose so there are no twists or sharp bends.
3. Using two wrenches, hold the hose in position and tighten flare nut 1/8 to 1/4 turn beyond hand tight. Final torque on the flare nut should be approximately 20 ft-lb.

## NPTF Pipe Thread Style

1. Screw fitting into female pipe port to the finger tight position.
2. Wrench tighten fitting to the appropriate turns from finger tight (TFFT) shown in chart stopping at the position where the joining tube can be attached. Avoid overtightening and then backing out the fitting to make the connection as this will likely result in a leaking or weeping connection.

Pipe Thread Size (NPTF)	TFFT
1/8-27	2.0 - 2.5
1/4-18	1.5 - 2.0
3/8-18	2.0 - 2.5
1/2-14	2.0 - 2.5
3/4-14 & Larger	1.5 - 2.0

The company reserves the right under its product improvement policy to change construction or design details and furnish equipment when so altered without reference to illustrations or specifications used.

Printed in U.S.A.