

Parts & Installation Instructions

Meyer Drive Pro™ Moldboard for Classic (TM) Mountings

Model DP 5'-0", DP 6'-0", DP 6'-8" & DP 7'-6"

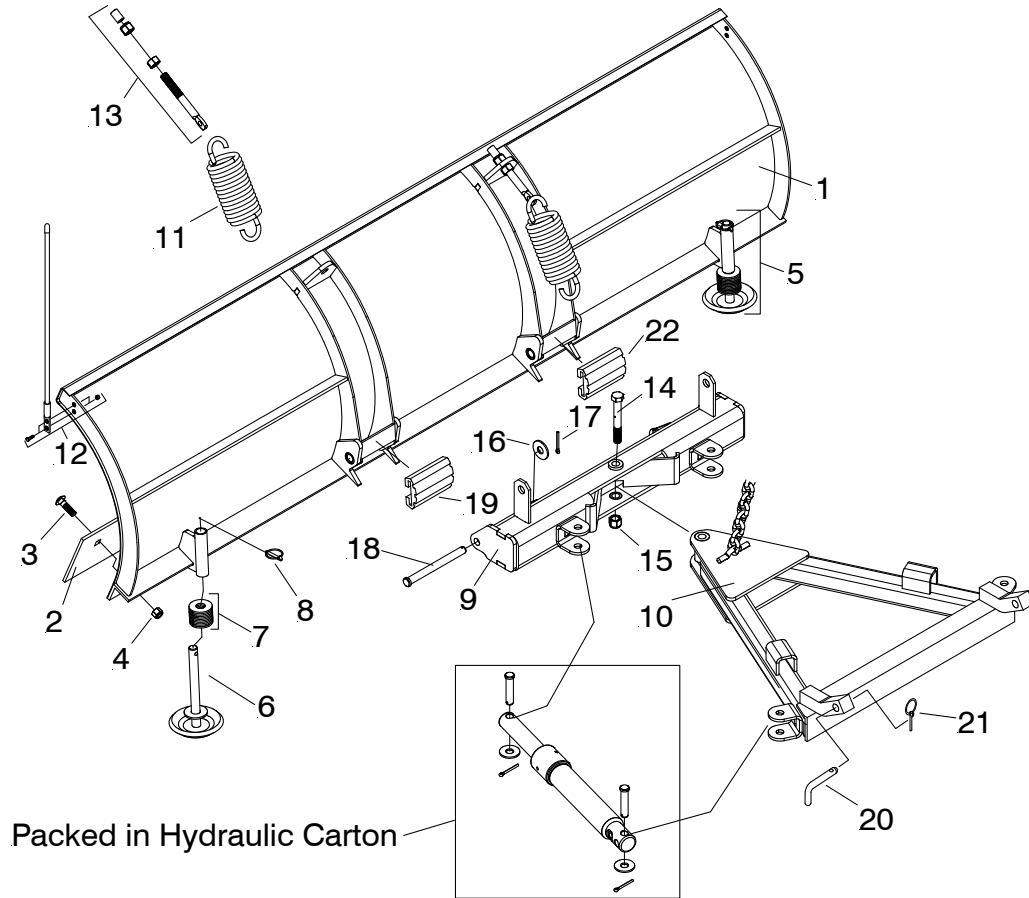

Parts List

Item	DP 5'-0"	DP 6'-0"	DP 6'-8"	DP 7'-6"	Qty.	Description
1	09320	09270	09274	09413	1	Drive Pro™ Moldboard Assembly
2	09319	09271	09277	09796	1	• Cutting Edge
3	21943	21943	21943	21943	6	• Bolt C 1/2-13 x 1-3/4" Gr. 5
4	20307	20307	20307	20307	6	• Locknut 1/2-13
5	09127	09127	09127	09127	2	• Runner Assembly
6	10853	10853	10853	10853	1	•• Mushroom Weldment
7	20359	20359	20359	20359	11	•• Flatwasher 3/4"
8	22083	22083	22083	22083	1	•• Lynch Pin
9	16607	16607	16607		1	PAF Drive Pro-Classic TM Mount
10	12959	12959	12959	12959	1	• Drive Pro™ Pivot Bar
11	13778	13778	13778	13778	1	• Drive Pro™ A-Frame Classic
12	12978	12978	12978	12978	2	• Trip Spring
13	08852	08852	08852	08852	1	• Plow Marker Kit
14	08157	08157	08157	08157	1	Hardware Bag
15	09124	09124	09124	09124	2	•• Eye Bolt
16	22005	22005	22005	22005	1	•• Bolt H 5/8-11 x 5-1/2" Gr. 8
17	20309	20309	20309	20309	1	•• Locknut 5/8-11
18	20357	20357	20357	20357	2	•• Flawasher 5/8"
19	20385	20385	20385	20385	2	•• Cotter Pin 1/8 x 1-1/4"
20	22720	22720	22720	22720	2	•• Pivot Pin 5/8 x 7"
21	22686	22686	22686	22686	2	•• Trip Bumper
22	11006	11006	11006	11006	2	•• Hinge Pin
23	22083	22083	22083	22083	2	•• Lynch Pin

Parts indented are included in the assembly under which they are indented.

INSTALLATION INSTRUCTIONS

- A. Attach Trip Bumper (19) to flat plate in front of pivot tubes of Moldboard (1).
- B. Attach pivot bar (9) to Moldboard (1) using pivot pins (18) coated with chassis lubricant, 5/8" Flatwasher (16) and 1/8 x 1-1/4" Cotter Pin (17). **(Note: Grease hole on modboard pivot tube)**
- C. Attach trip springs (11) to pivot bar (9) and moldboard (1) with eye bolts (13). Flat end of eye bolt (13) must be in a vertical position, as shown in Figure 2, to hinge properly when moldboard (1) trips. Proper tension is attained when trip spring (11) coils begin to separate and then tighten top locknut four additional turns. Tighten bottom Finish nut to secure eye bolt (13) in position. Install Eye Bolt Caps over threads.
- D. Assemble A-Frame (10) to pivot bar (9) using Bolt (14) and locknut (15).
- E. Install power angling rams with hoses to A-Frame (10) and piston end of ram to pivot bar (9) using hardware bag packed in the Hydraulic Carton.
- F. Straighten end of plow markers (8) so they will be vertical after installation. Attach using 1/4-20 x 1" bolt, clamp, lockwasher and nut.
- G. Secure the moldboard-pivot bar-A-frame assembly to vehicle at the clevis frame using Hinge Pins (20) and Lynch Pin (21). Attach lift chain to lift arm allowing sufficient slack to allow moldboard to follow ground contours.

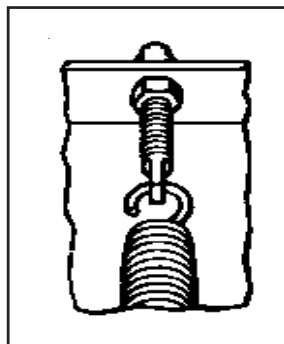

Figure 2

