

Parts & Installation Instructions

Steel Road Pro Moldboards

Models RP-9.0, RP-10.0 and RP-11.0

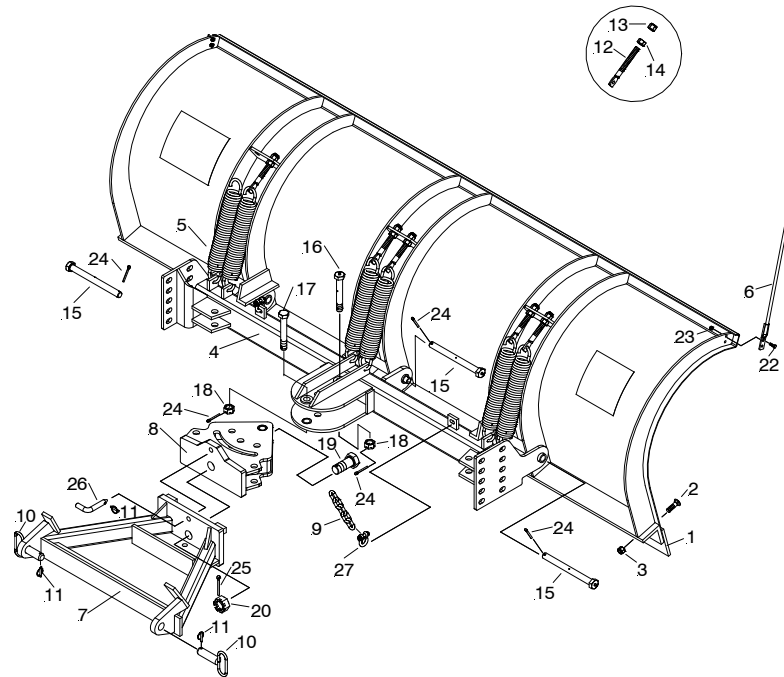

Parts List

Item	RP-9.0 Part No.	RP-10.0 Part No.	RP-11.0 Part No.	Qty.	Description
					Moldboard Assembly
1	09299	09287	09290	1	Moldboard Assembly
2	07259	07235	07257	1	• Cutting Edge
2	21960	-----	-----	11	• Bolt C 5/8-11 x 2-1/4" Gr. 5
2	-----	21960	-----	12	• Bolt C 5/8-11 x 2-1/4" Gr. 5
2	-----	-----	21960	14	• Bolt C 5/8-11 x 2-1/4" Gr. 5
3	20309	-----	-----	11	• Locknut 5/8-11
3	-----	20309	-----	12	• Locknut 5/8-11
3	-----	-----	20309	14	• Locknut 5/8-11
4	12300	12300	12300	1	RP Pivot Bar
					RP A-Frame Carton
5	16521	16521	16521	6	• Trip Spring
6	07238	07238	07238	2	• Plow Marker
7	811000095	811000095	811000095	1	• RP A-Frame 20" x 30-1/2"
8	13671	13671	13671	1	• RP Push Plate Weldment
9	13670	13670	13670	1	• RP Push Plate Weldment
9	22289	22289	22289	1	• 3/8 x 64" Lift Chain Gr. 70
10	08772	08772	08772	1	• Hardware Bag
11	19005	19005	19005	2	• Pin - Yellow Handle
12	22083	22083	22083	3	• Lynch Pin
13	12344	12344	12344	6	• AG Eyebolt
14	20310	20310	20310	6	• H 3/4-10 Locknut CP
15	20531	20531	20531	6	• H 3/4-10 Finish Nut CP
16	22271	22271	22271	3	• Bolt H 1" x 11 King Pivot w/Grease Ftg.
17	22272	22272	22272	1	• Bolt H 1"-8 x 6-1/2 King Pivot w/Grease Ftg.
18	22273	22273	22273	1	• Bolt H 1"-8 x 6-1/2 Pivot
19	22274	22274	22274	2	• 1"-8 Slotted Hex nut
20	22275	22275	22275	1	• Bolt H 1-1/2 -6 x 3-1/2" Pivot
21	22276	22276	22276	1	• 1-1/2"-6 Slotted Hex Nut
22	21262	21262	21262	4	• Flatwasher 1" SAE CP
23	20027	20027	20027	4	• Bolt 5/16-18 x 1"
24	20304	20304	20304	4	• Locknut 5/16-18
25	20420	20420	20420	5	• 1/4 DIA. x 2" Cotter Pin CP
26	20435	20435	20435	1	• 5/16 DIA. x 3" Cotter Pin CP
27	19063	19063	19063	1	• 3/4 Hinge Pin
28	22278	22278	22278	2	• Anchor Shackle w/Safety Pin
28	07268	07268	07268	6	• 1" Cap-RP Eyebolt

Parts indented are included in the assembly under which they are indented.

Meyer Products reserves the right, under its continuing product improvement program, to change construction or design details, specifications and prices without notice or without incurring any obligation.

INSTALLATION INSTRUCTIONS

Note: The following instructions cover assembly of Moldboard, Pivot Bar and A-Frame. Refer to separate instructions for installation of plow mounting and hydraulic system.

- A. Liberally coat King Pivot Bolts (15) with chassis lubricant. Attach Pivot bar (4) to Moldboard with King Pivot Bolts (15) and insert and bend Cotter Pins (24).
- B. Attach Trip Springs (5) to Pivot bar (4) and Eye Bolts (12) then to Moldboard making certain nuts (13 & 14) are positioned as shown in Figure 3. **Notes:** Make certain each Eye Bolt (12) is in a vertical position as shown in Figure 3 so that the Eye Bolt (12) and Trip Spring (5) hinge properly when moldboard trips. Proper tension is attained when Trip Spring's (5) coils just begin to separate and then tightening top locknut four additional turns. Insert rubber caps (28) over the ends of Eybolts.
- C. Liberally coat King Pivot Bolt (16) and the insides of Pivot Bar (4) receiver plates with chassis lubricant. Attach Push Plate Weld (8) to Pivot bar (4) using King Pivot Bolt (16), Pivot Bolt (17), 1" Slotted Hex Nuts (18), 1/4" Cotter Pins (24) as shown in main assembly diagram. **Note:** All slotted slot hex nuts (18 & 20) are to be tightened snug, but loose enough to allow parts to pivot freely. Figures 1 & 2 shows an alternative configuration for three rigid angling positions if power angling rams are not used. In this case 4 (2 on top, 2 on bottom) 1" Washers (21) must be used with Pivot Bolt (17).
- D. Liberally coat front Plate on A-frame (7) with chassis lubricant. Attach A-Frame (7) to Push Plate Weld (8) using the 1 1/2" Pivot Bolt (19), 1 1/2" Slotted Hex Nut (20), and 5/16" Cotter Pin (25) as shown on main diagram. 3/4 Hinge Pin (26) with Lynch Pin (11) may be used in top A-Frame hole if side to side moldboard float is not desired.
- E. Attach plow assembly to mounting holes using Yellow Handled Pins (10) with Lynch Pins (11)
- F. Remove saftey pins, nuts, and bolts from Anchor Shackle (27) and insert one leg through the small slotted plates on each side of the Pivot Bar. Attach one end of Chain (9) to the bolt removed in last sentence and renstall nut and saftey pin. Run 3/8 Chain (9) through Sling (19060) supplied in mounting kit and then attach to the opposite Shackle bolt. **Note:** Attach chain link that leaves between 1-1 1/2" of lift ram stroke when tight to allow plow to float.
- G. Grease all King Pivot Bolts with grease fittings on the heads. Regrease weekly while in use.

