

35211

MOUNT KIT

John Deere 835/865

2017-__

Installation Instructions

▲ CAUTION

Read this document before installing the snowplow.

▲ CAUTION

See your sales outlet/website for specific vehicle application recommendations before installation. The online selection tool has specific vehicle and snowplow requirements.

SAFETY DEFINITIONS

⚠ WARNING

Indicates a potentially hazardous situation that, if not avoided, could result in death or serious personal injury.

⚠ CAUTION

Indicates a potentially hazardous situation that, if not avoided, may result in minor or moderate injury. It may also be used to alert against unsafe practices.

NOTE: Indicates a situation or action that can lead to damage to your snowplow and vehicle or other property. Other useful information can also be described.

WARNING/CAUTION & INSTRUCTION LABELS

Become familiar with and inform users about the warning/caution and instruction labels on the back of the blade.

NOTE: If labels are missing or cannot be read, see your sales outlet.

Attach/Detach Label

<p>ATTACH</p> <ol style="list-style-type: none"> Verify that plow control in vehicle is disconnected. Slowly drive vehicle forward to engage rear headgear arms into receiver slots, bottoming out headgear arms in slots. Plug in electrical harness. Plug in plow control in vehicle. Press plow control switch down to activate FLOAT. On driver's side, pull up on headgear to relieve pressure on connecting pins while pulling driver's side connecting pin out. Rotate pin toward mount; insert it into connecting pin hole. Verify that connecting pin is engaged in mount (through outside & inside plates) and extends approximately 1/8" through the plate. Repeat on passenger's side. Remove wire-lock clevis pin. Fully raise jack stand up, insert pin in hole & engage wire lock. 	<p>⚠ WARNING</p> <p>Keep fingers away from snowplow and UTV attachment points.</p> <p>ATTACH – Steps 4, 5, & 6 DETACH – Step 3</p> <p>ATTACH – Step 7 DETACH – Step 2 & 4</p>
<p>DETACH</p> <ol style="list-style-type: none"> With blade straight, lower snowplow to the ground. Press plow control switch down to activate FLOAT. Remove wire-lock clevis pin. Fully lower jack stand. Insert pin in jack stand hole that aligns with hole in angle frame. Engage the wire lock. On driver's side, pull up slightly on headgear to relieve pressure on connecting pin while removing the pin. Rotate pin & insert into hole in headgear. Repeat on passenger's side. Unplug electrical harness. Unplug plow control in vehicle. Back vehicle away to disconnect headgear from receivers. 	<p>⚠ WARNING</p> <p>Read Owner's Manual for complete instructions.</p>

Warning/Caution Label

<p>⚠ WARNING</p> <p>Blade could drop unexpectedly, crushing or trapping limbs. Lower blade when vehicle is parked.</p> <p>Overloading could negatively affect vehicle handling. To avoid serious injury or death, do not exceed maximum vehicle load capacity, including blade and ballast.</p>	<p>⚠ CAUTION</p> <p>Read Owner's Manual before operating or servicing snowplow.</p> <p>Transport speed should not exceed 20 mph (32 km/h). Further reduce speed under adverse travel conditions.</p> <p>Plowing speed should not exceed 10 mph (16 km/h).</p> <p>See your sales outlet/website for specific vehicle application recommendations.</p>
--	---

Warning Label

<p>⚠ WARNING</p>	<p>HIGH-PRESSURE FLUID HAZARD</p> <p>To prevent serious injury or death:</p> <ul style="list-style-type: none"> Relieve pressure on hydraulic system before servicing or disconnecting. Wear proper hand and eye protection when searching for leaks. Use wood or cardboard instead of hands. Keep all components in good repair.
-------------------------	---

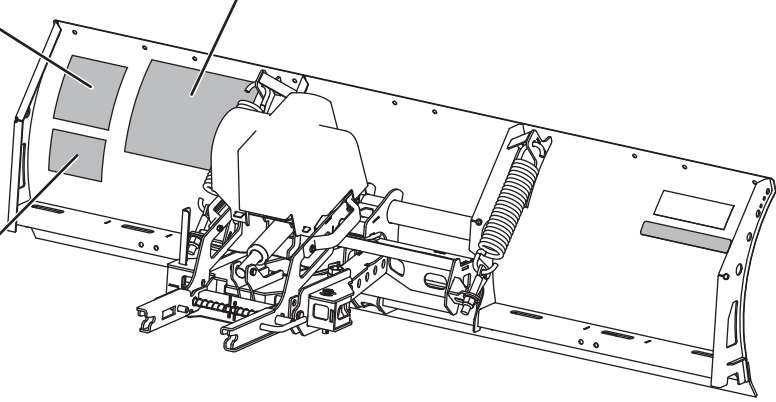

SAFETY PRECAUTIONS

Follow all safety and operating instructions in your UTV owner's manual.

Improper installation and operation could cause personal injury, and/or equipment and property damage. Read and understand labels and the Owner's Manual before installing, operating, or making adjustments.

⚠ WARNING

Lower the blade when vehicle is parked. Temperature changes could change hydraulic pressure, causing the blade to drop unexpectedly or damaging hydraulic components. Failure to do this could result in serious personal injury.

⚠ WARNING

The driver shall keep bystanders clear of the blade when it is being raised, lowered, or angled. Do not stand between vehicle and blade or within 8 feet of a moving blade. A moving or falling blade could cause personal injury.

⚠ WARNING

Keep hands and feet clear of the blade and A-frame when mounting or removing the snowplow. Moving or falling assemblies could cause personal injury.

⚠ WARNING

Do not exceed GVWR, GAWR, or maximum vehicle load capacity, including the blade and ballast.

⚠ WARNING

To prevent accidental movement of the blade, always turn the control OFF whenever the snowplow is not in use. The power indicator light will turn OFF.

⚠ WARNING

Remove blade assembly before placing vehicle on hoist.

⚠ WARNING

Vehicle mount reduces ground clearance. Use additional caution when driving vehicle with mount installed. Remove vehicle mount to restore original vehicle ground clearance at the end of the plowing season.

⚠ CAUTION

Refer to the online selection tool for minimum vehicle recommendations and ballast requirements.

PERSONAL SAFETY

- Remove the ignition key and put the vehicle in PARK or in gear to prevent others from starting the vehicle during installation or service.
- Wear only snug-fitting clothing while working on your vehicle or snowplow.
- Do not wear jewelry or a necktie, and secure long hair.
- Wear safety goggles to protect your eyes from battery acid, gasoline, dirt, and dust.
- Avoid touching hot surfaces such as the engine, radiator, hoses, and exhaust pipes.
- Always have a fire extinguisher rated BC handy, for flammable liquids and electrical fires.

FIRE AND EXPLOSION

⚠ WARNING

Gasoline is highly flammable and gasoline vapor is explosive. Never smoke while working on vehicle. Keep all open flames away from gasoline tank and lines. Wipe up any spilled gasoline immediately.

Be careful when using gasoline. Do not use gasoline to clean parts. Store only in approved containers away from sources of heat or flame.

CELL PHONES

A driver's first responsibility is the safe operation of the vehicle. The most important thing you can do to prevent a crash is to avoid distractions and pay attention to the road. Wait until it is safe to operate mobile communication equipment such as cell phones, text messaging devices, pagers, or two-way radios.

VENTILATION

⚠ WARNING	
<p>Vehicle exhaust contains lethal fumes. Breathing these fumes, even in low concentrations, can cause death. Never operate a vehicle in an enclosed area without venting exhaust to the outside.</p>	

NOISE









Airborne noise emission during use is below 95 dB(A) for the snowplow operator.

VIBRATION

Operating snowplow vibration does not exceed 2.5 m/s² to the hand-arm or 0.5 m/s² to the whole body.

TORQUE CHART

⚠ CAUTION	
<p>Read instructions before assembling. Fasteners should be finger tight until instructed to tighten according to the torque chart. Use standard methods and practices when attaching snowplow, including proper personal protective safety equipment.</p>	

Recommended Fastener Torque Chart					
Inch Fasteners Grade 5 and Grade 8					
Size	Torque (ft-lb)		Size	Torque (ft-lb)	
	 Grade 5	 Grade 8		 Grade 5	 Grade 8
1/4-20	8.4	11.9	9/16-12	109	154
1/4-28	9.7	13.7	9/16-18	121	171
5/16-18	17.4	24.6	5/8-11	150	212
5/16-24	19.2	27.3	5/8-18	170	240
3/8-16	30.8	43.6	3/4-10	269	376
3/8-24	35.0	49.4	3/4-16	297	420
7/16-14	49.4	69.8	7/8-9	429	606
7/16-20	55.2	77.9	7/8-14	474	669
1/2-13	75.3	106.4	1-8	644	909
1/2-20	85.0	120.0	1-12	704	995
Metric Fasteners Class 8.8 and 10.9					
Size	Torque (ft-lb)		Size	Torque (ft-lb)	
	 Class 8.8	 Class 10.9		 Class 8.8	 Class 10.9
M6 x 1.00	7.7	11.1	M20 x 2.50	325	450
M8 x 1.25	19.5	26.9	M22 x 2.50	428	613
M10 x 1.50	38.5	53.3	M24 x 3.00	562	778
M12 x 1.75	67	93	M27 x 3.00	796	1139
M14 x 2.00	107	148	M30 x 3.50	1117	1545
M16 x 2.00	167	231	M33 x 3.50	1468	2101
M18 x 2.50	222	318	M36 x 4.00	1952	2701
<p>These torque values apply to fasteners except those noted in the instructions.</p>					

INSTALLATION INSTRUCTIONS

NOTE: For easier assembly and installation, the vehicle and all snowplow components should be on a smooth, level, hard surface, such as concrete.

1. Remove the front skid plate.

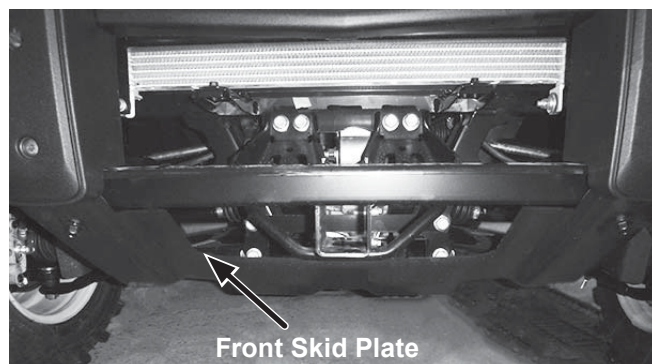

2. Place a 3/8" washer on each of two 3/8" x 3" cap screws. Starting on the driver's side, position a bracket over the top of the winch mount plate of the brush guard. Install the fasteners through the bracket and winch mount plate as shown.

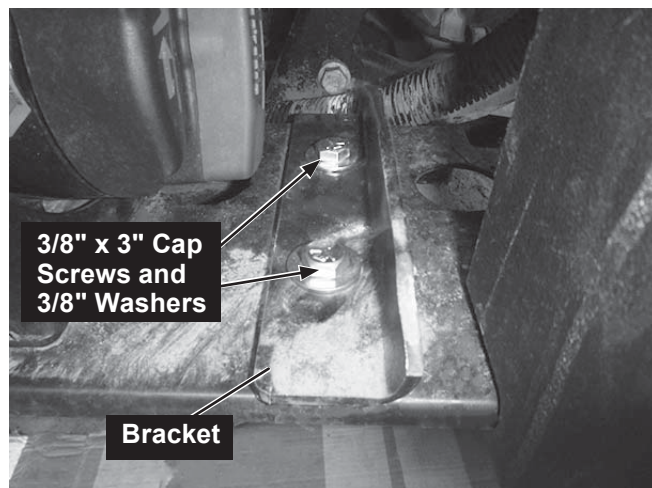

3. Slide a bracket assembly over the 3/8" fasteners protruding through the bottom of the winch mount plate. Fasten the bracket assembly to the winch mount plate using 3/8" washers and 3/8" locknuts as shown. Hand tighten the fasteners.

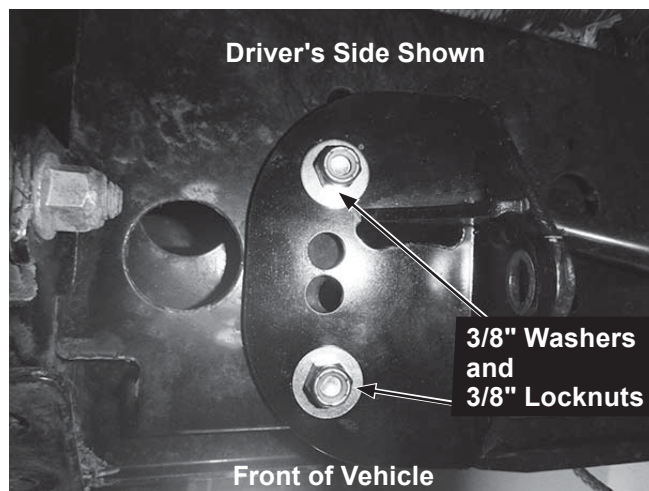

4. Repeat Steps 2 and 3 on the passenger's side of the vehicle.
5. On the driver's side of the vehicle, install the left-hand frame brace to the upright frame member using a 3/8" x 1" cap screw with a 3/8" washer. Secure with a 3/8" washer and 3/8" locknut. Fasten the frame brace to the brush guard using 3/8" x 1" cap screws with 3/8" washers and secure with 3/8" washers and 3/8" locknuts. Hand tighten the fasteners. Check that the frame brace has clearance between all hoses/cables. Use a spacer (provided) between the brace and brush guard to provide clearance if necessary. The anti-chafe material provided may be installed for additional protection.

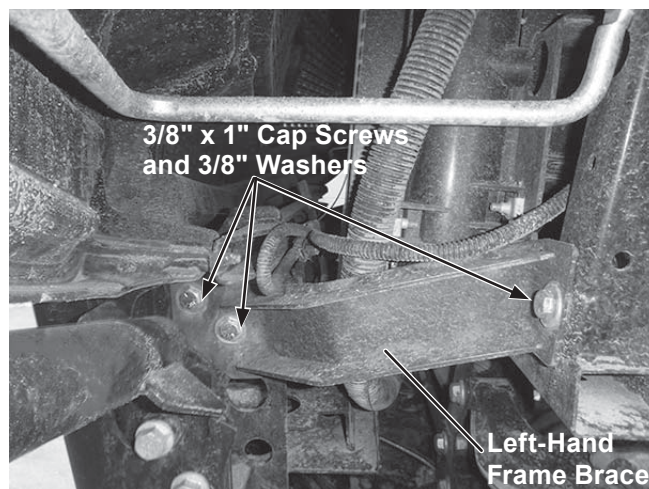

6. On the passenger's side of the vehicle, install the right-hand frame brace to the upright frame member using a 3/8" x 1" cap screw with a 3/8" washer. Secure with a 3/8" washer and 3/8" locknut. Fasten the frame brace to the brush guard using 3/8" cap screws with 3/8" washers and secure with 3/8" washers and 3/8" locknuts. Hand tighten the fasteners. For vehicles equipped with a right-hand cooling line (shown), install a spacer between the frame brace and brush guard prior to securing the brace to the brush guard. Secure the anti-chafing material to the cooling line in the vicinity of the frame brace.

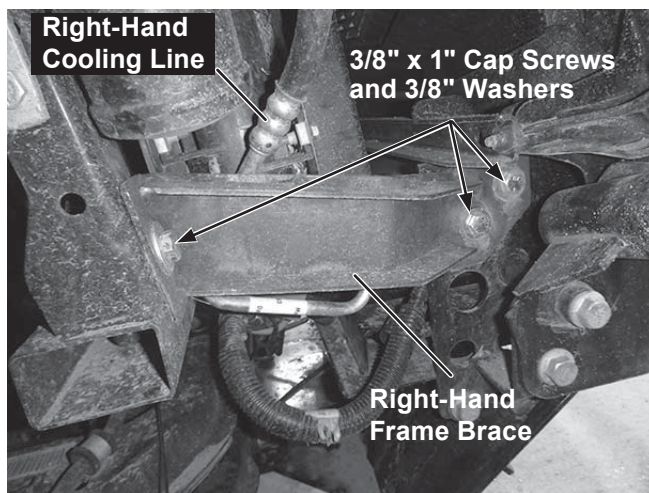

7. Install a 1/2" x 1-1/4" cap screw with handle into the frame on the passenger's side. Insert the fastener through the front most hole; bend the handle as necessary. Install a second cap screw on handle farther into the frame and through the second hole rearward from where the first cap screw on handle was inserted.

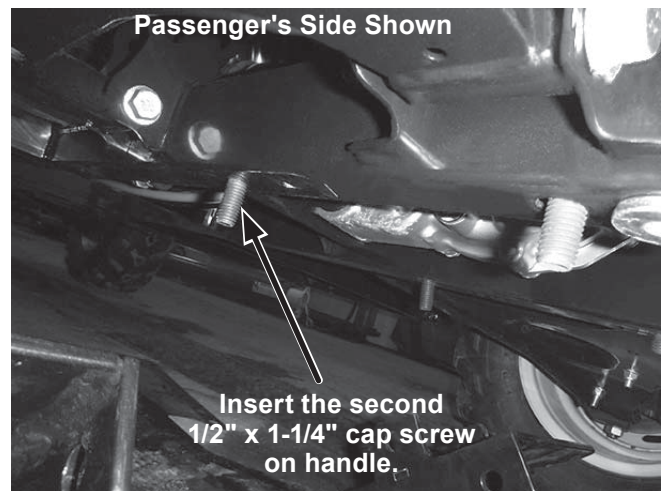
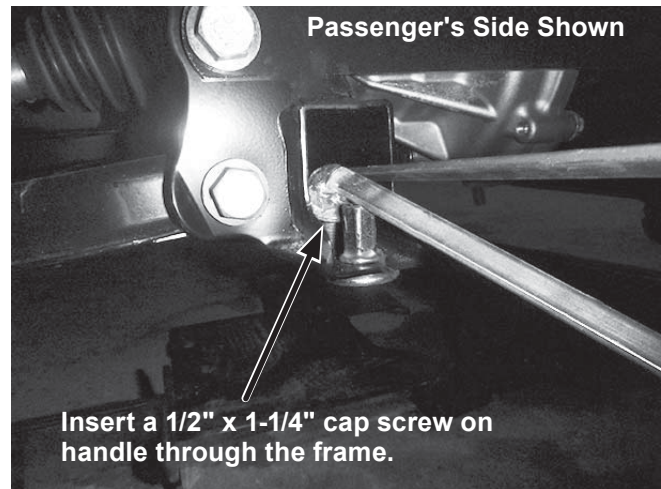

8. Repeat Step 7 on the driver's side.

9. Place the skid plate assembly up against the vehicle frame, allowing the cap screws on handles to protrude through the corresponding holes in the assembly. The front portion of the skid plate assembly should line up with the bracket assemblies installed in Steps 3 and 4 as shown.

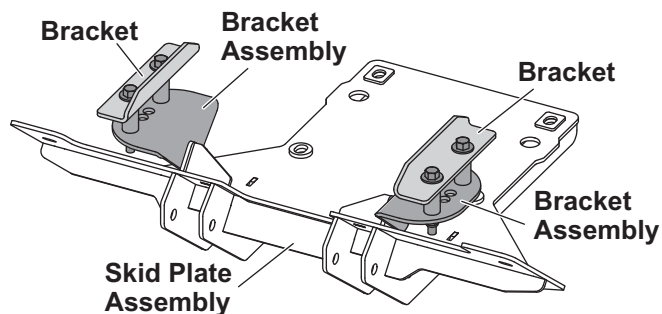

Secure the cap screws on handles with 1/2" washers and 1/2" locknuts.

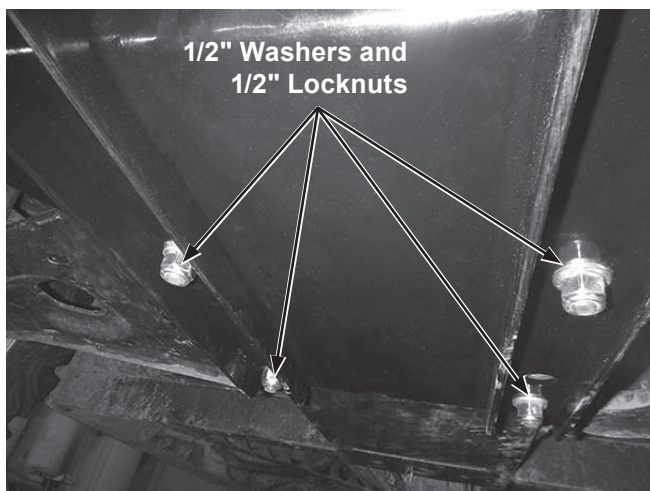

10. Fasten the skid plate assembly to the bracket assemblies installed in Steps 3 and 4 using one 1/2" x 1-1/4" cap screw and 1/2" locknut per side.

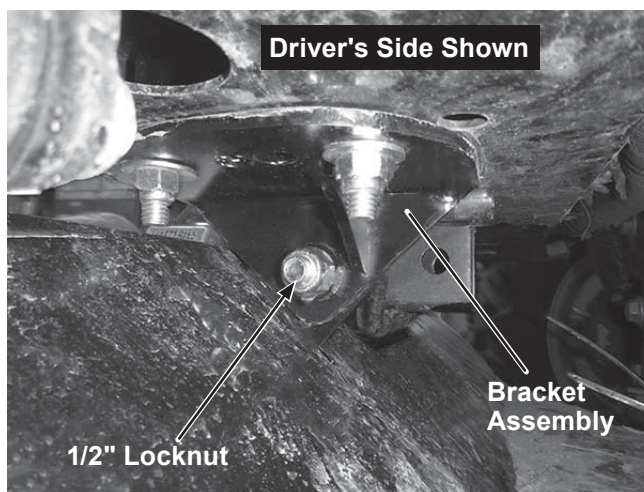

11. On the passenger's side, secure the outer edges of the skid plate assembly to the front flange of the brush guard using a 3/8" x 1" cap screw with a 3/8" washer. Secure the fastener with a 3/8" washer and 3/8" locknut.

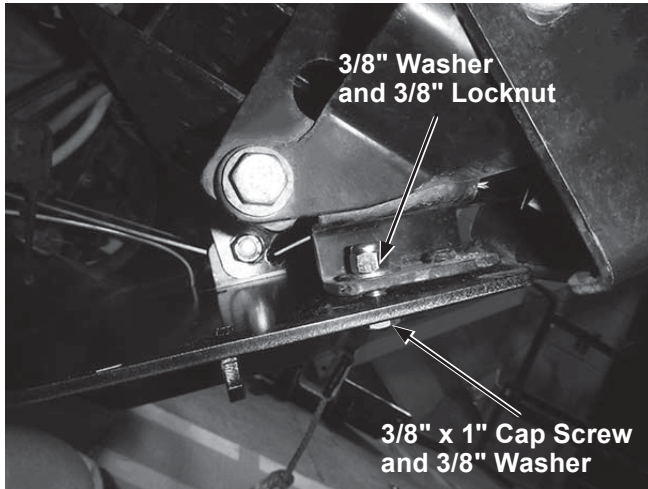

12. Repeat Step 11 on the driver's side.
13. Tighten all fasteners according to the torque chart.
14. Trim the excess handle lengths of cap screw with handles installed in Step 7.
15. Install the receivers into the skid plate assembly using the supplied clevis pins. Secure the clevis pins with the hairpin cotters. The receivers may be removed when not in use to provide additional ground clearance.

NOTE: After five to ten hours of snowplow usage, retorque all mount assembly fasteners.

The company reserves the right under its product improvement policy to change construction or design details and furnish equipment when so altered without reference to illustrations or specifications used. This equipment manufacturer or the vehicle manufacturer may require or recommend optional equipment for snow removal. Do not exceed vehicle ratings with a snowplow. The company offers a limited warranty for all snowplows and accessories. See separately printed page for this important information.

Printed in U.S.A.