

# 35200-1

## MOUNT KIT

John Deere XUV590

2017-\_\_

### Installation Instructions

**▲ CAUTION**

Read this document before installing the snowplow.

**▲ CAUTION**

See your sales outlet/website for specific vehicle application recommendations before installation. The online selection tool has specific vehicle and snowplow requirements.

**SAFETY DEFINITIONS**

**⚠ WARNING**  
 Indicates a potentially hazardous situation that, if not avoided, could result in death or serious personal injury.

**⚠ CAUTION**  
 Indicates a potentially hazardous situation that, if not avoided, may result in minor or moderate injury. It may also be used to alert against unsafe practices.

**NOTE:** Indicates a situation or action that can lead to damage to your snowplow and vehicle or other property. Other useful information can also be described.

**WARNING/CAUTION & INSTRUCTION LABELS**

Become familiar with and inform users about the warning/caution and instruction labels on the back of the blade.

**NOTE:** If labels are missing or cannot be read, see your sales outlet.

**Attach/Detach Label**

<p><b>ATTACH</b></p> <ol style="list-style-type: none"> <li>1. Verify that plow control in vehicle is disconnected. Slowly drive vehicle forward to engage rear headgear arms into receiver slots, bottoming out headgear arms in slots.</li> <li>2. Plug in electrical harness.</li> <li>3. Plug in plow control in vehicle. Press plow control switch down to activate FLOAT.</li> <li>4. On driver's side, pull up on headgear to relieve pressure on connecting pins while pulling driver's side connecting pin out. Rotate pin toward mount; insert it into connecting pin hole.</li> <li>5. Verify that connecting pin is engaged in mount (through outside &amp; inside plates) and extends approximately 1/8" through the plate.</li> <li>6. Repeat on passenger's side.</li> <li>7. Remove wire-lock clevis pin. Fully raise jack stand up. Insert pin in hole &amp; engage wire lock.</li> </ol>	<p><b>⚠ WARNING</b>                  Keep fingers away from snowplow and UTV attachment points.</p> <p><b>ATTACH - Steps 4, 5, &amp; 6</b>  <b>DETACH - Step 7</b></p>
<p><b>DETACH</b></p> <ol style="list-style-type: none"> <li>1. With blade straight, lower snowplow to the ground. Press plow control switch down to activate FLOAT.</li> <li>2. Remove wire-lock clevis pins. Fully lower jack stand. Insert pin in jack stand hole that aligns with hole in angle frame. Engage the wire lock.</li> <li>3. On driver's side, pull up slightly on headgear to relieve pressure on connecting pin while removing the pin. Rotate pin &amp; insert into hole in headgear.</li> <li>4. Repeat on passenger's side.</li> <li>5. Unplug electrical harness. Unplug plow control in vehicle.</li> <li>6. Back vehicle away to disconnect headgear from receivers.</li> </ol>	<p><b>⚠ WARNING</b>                  Keep fingers away from snowplow and UTV attachment points.</p> <p><b>ATTACH - Step 7</b>  <b>DETACH - Step 2 &amp; 4</b></p>

-OR-

<p><b>ATTACH</b></p> <ol style="list-style-type: none"> <li>1. Slowly drive vehicle forward to engage rear headgear arms into receiver slots, bottoming out headgear arms in slots.</li> <li>2. On driver's side, pull up on headgear to relieve pressure on connecting pins while pulling driver's side connecting pin out. Rotate pin toward mount; insert it into connecting pin hole.</li> <li>3. Verify that connecting pin is engaged in mount (through outside &amp; inside plates) and extends approximately 1/8" through the plate.</li> <li>4. Repeat on passenger's side.</li> <li>5. Remove jack stand wire-lock clevis pin. Fully raise jack stand up. Insert pin in hole and engage wire lock.</li> <li>6. Remove cable-restraining wire-lock clevis pin. Route winch cable/rope around pulley &amp; secure to lift pin. Re-insert clevis pin &amp; engage wire lock.</li> </ol>	<p><b>⚠ WARNING</b>                  Keep fingers away from snowplow and UTV attachment points.</p> <p><b>ATTACH - Steps 2, 3, &amp; 6</b>  <b>DETACH - Step 5</b></p>
<p><b>DETACH</b></p> <ol style="list-style-type: none"> <li>1. With blade straight, lower snowplow to the ground. Let out approximately 2" more cable after blade contacts the ground.</li> <li>2. Remove jack stand wire-lock clevis pin. Fully lower jack stand. Insert pin in jack stand hole that aligns with hole in angle frame. Engage wire lock.</li> <li>3. On driver's side, pull up slightly on headgear to relieve pressure on connecting pin while removing the pin. Rotate pin &amp; insert into hole in headgear.</li> <li>4. Repeat on passenger's side.</li> <li>5. Remove cable restraining wire-lock clevis pins. Remove winch cable/rope from lift pin and pulley. Reinsert clevis pin and wire lock. Reinsert cable fully onto winch.</li> <li>6. Back vehicle away to disconnect headgear from receivers.</li> </ol>	<p><b>⚠ WARNING</b>                  Keep fingers away from snowplow and UTV attachment points.</p> <p><b>ATTACH - Step 5 &amp; 6</b>  <b>DETACH - Step 5</b></p>

**Warning/Caution Label**

<p><b>⚠ WARNING</b></p> <p>Blade could drop unexpectedly, crushing or trapping limbs. Lower blade when vehicle is parked.</p> <p>Overloading could negatively affect vehicle handling. To avoid serious injury or death, do not exceed maximum vehicle load capacity, including blade and ballast.</p>
<p><b>⚠ CAUTION</b></p> <p>Read Owner's Manual before operating or servicing snowplow.</p> <p>Transport speed should not exceed 20 mph (32 km/h). Further reduce speed under adverse travel conditions.</p> <p>Plowing speed should not exceed 10 mph (16 km/h).</p> <p><b>WWW.</b> See your sales outlet/website for specific vehicle application recommendations.</p>

**Warning Label**

<p><b>⚠ WARNING</b></p> <p><b>HIGH-PRESSURE FLUID HAZARD</b></p> <p>To prevent serious injury or death:</p> <ul style="list-style-type: none"> <li>Relieve pressure on hydraulic system before servicing or disconnecting.</li> <li>Wear proper hand and eye protection when searching for leaks. Use wood or cardboard instead of hands.</li> <li>Keep all components in good repair.</li> </ul>
---

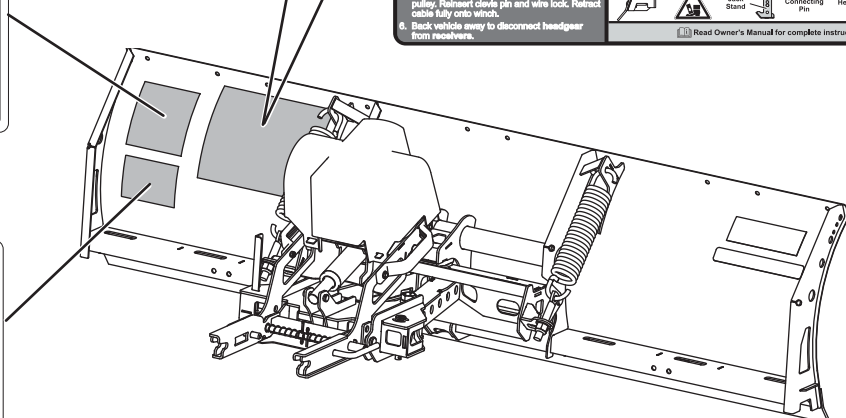

## SAFETY PRECAUTIONS

Follow all safety and operating instructions in your UTV owner's manual.

Improper installation and operation could cause personal injury, and/or equipment and property damage. Read and understand labels and the Owner's Manual before installing, operating, or making adjustments.

### **⚠ WARNING**

Lower the blade when vehicle is parked. Temperature changes could change hydraulic pressure, causing the blade to drop unexpectedly or damaging hydraulic components. Failure to do this could result in serious personal injury.

### **⚠ WARNING**

The driver shall keep bystanders clear of the blade when it is being raised, lowered, or angled. Do not stand between vehicle and blade or within 8 feet of a moving blade. A moving or falling blade could cause personal injury.

### **⚠ WARNING**

Keep hands and feet clear of the blade and A-frame when mounting or removing the snowplow. Moving or falling assemblies could cause personal injury.

### **⚠ WARNING**

Do not exceed GVWR, GAWR, or maximum vehicle load capacity, including the blade and ballast.

### **⚠ WARNING**

To prevent accidental movement of the blade, always turn the control OFF whenever the snowplow is not in use. The power indicator light will turn OFF.

### **⚠ WARNING**

Remove blade assembly before placing vehicle on hoist.

### **⚠ WARNING**

Vehicle mount reduces ground clearance. Use additional caution when driving vehicle with mount installed. Remove vehicle mount to restore original vehicle ground clearance at the end of the plowing season.

### **⚠ CAUTION**

Refer to the online selection tool for minimum vehicle recommendations and ballast requirements.

## PERSONAL SAFETY

- Remove the ignition key and put the vehicle in PARK or in gear to prevent others from starting the vehicle during installation or service.
- Wear only snug-fitting clothing while working on your vehicle or snowplow.
- Do not wear jewelry or a necktie, and secure long hair.
- Wear safety goggles to protect your eyes from battery acid, gasoline, dirt, and dust.
- Avoid touching hot surfaces such as the engine, radiator, hoses, and exhaust pipes.
- Always have a fire extinguisher rated BC handy, for flammable liquids and electrical fires.

## FIRE AND EXPLOSION

### **⚠ WARNING**

Gasoline is highly flammable and gasoline vapor is explosive. Never smoke while working on vehicle. Keep all open flames away from gasoline tank and lines. Wipe up any spilled gasoline immediately.

Be careful when using gasoline. Do not use gasoline to clean parts. Store only in approved containers away from sources of heat or flame.

**CELL PHONES**

A driver's first responsibility is the safe operation of the vehicle. The most important thing you can do to prevent a crash is to avoid distractions and pay attention to the road. Wait until it is safe to operate mobile communication equipment such as cell phones, text messaging devices, pagers, or two-way radios.

**VENTILATION**

 <b>WARNING</b>
<p><b>Vehicle exhaust contains lethal fumes. Breathing these fumes, even in low concentrations, can cause death. Never operate a vehicle in an enclosed area without venting exhaust to the outside.</b></p>

**NOISE**









Airborne noise emission during use is below 95 dB(A) for the snowplow operator.

**VIBRATION**

Operating snowplow vibration does not exceed 2.5 m/s<sup>2</sup> to the hand-arm or 0.5 m/s<sup>2</sup> to the whole body.

**TORQUE CHART**

 <b>CAUTION</b>
<p><b>Read instructions before assembling. Fasteners should be finger tight until instructed to tighten according to the torque chart. Use standard methods and practices when attaching snowplow, including proper personal protective safety equipment.</b></p>

<b>Recommended Fastener Torque Chart</b>					
<b>Inch Fasteners Grade 5 and Grade 8</b>					
Size	Torque (ft-lb)		Size	Torque (ft-lb)	
	 Grade 5	 Grade 8		 Grade 5	 Grade 8
1/4-20	8.4	11.9	9/16-12	109	154
1/4-28	9.7	13.7	9/16-18	121	171
5/16-18	17.4	24.6	5/8-11	150	212
5/16-24	19.2	27.3	5/8-18	170	240
3/8-16	30.8	43.6	3/4-10	269	376
3/8-24	35.0	49.4	3/4-16	297	420
7/16-14	49.4	69.8	7/8-9	429	606
7/16-20	55.2	77.9	7/8-14	474	669
1/2-13	75.3	106.4	1-8	644	909
1/2-20	85.0	120.0	1-12	704	995
<b>Metric Fasteners Class 8.8 and 10.9</b>					
Size	Torque (ft-lb)		Size	Torque (ft-lb)	
	 Class 8.8	 Class 10.9		 Class 8.8	 Class 10.9
M6 x 1.00	7.7	11.1	M20 x 2.50	325	450
M8 x 1.25	19.5	26.9	M22 x 2.50	428	613
M10 x 1.50	38.5	53.3	M24 x 3.00	562	778
M12 x 1.75	67	93	M27 x 3.00	796	1139
M14 x 2.00	107	148	M30 x 3.50	1117	1545
M16 x 2.00	167	231	M33 x 3.50	1468	2101
M18 x 2.50	222	318	M36 x 4.00	1952	2701
These torque values apply to fasteners except those noted in the instructions.					

## INSTALLATION INSTRUCTIONS

**NOTE: For easier assembly and installation, the vehicle and all snowplow components should be on a smooth, level, hard surface, such as concrete.**

1. Remove one lower winch plate fastener from each side.

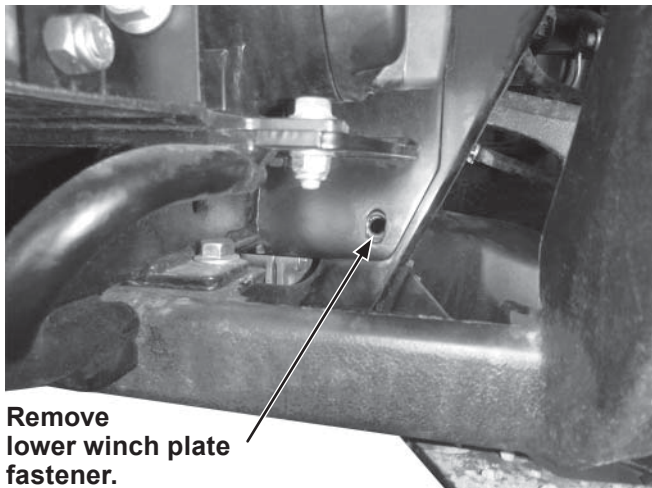

2. Remove the four lower brush guard support bracket fasteners.

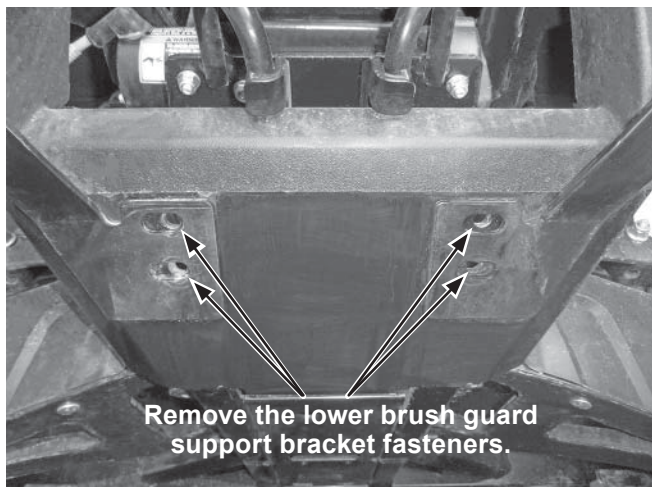

3. Position the driver-side mount bracket over the winch plate mounting hole as shown. Place a 3/8" washer onto a 3/8" x 1-1/2" cap screw and install the fastener through the vehicle frame, winch mount plate, and bracket as shown.

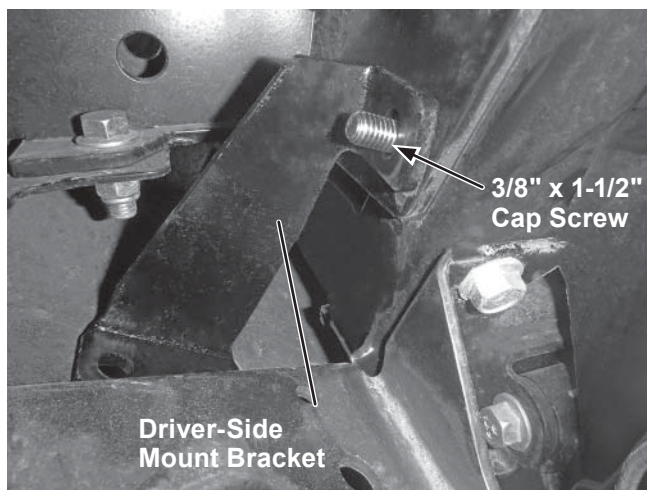

4. Install a 3/8" washer and 3/8" locknut on the cap screw and hand tighten.

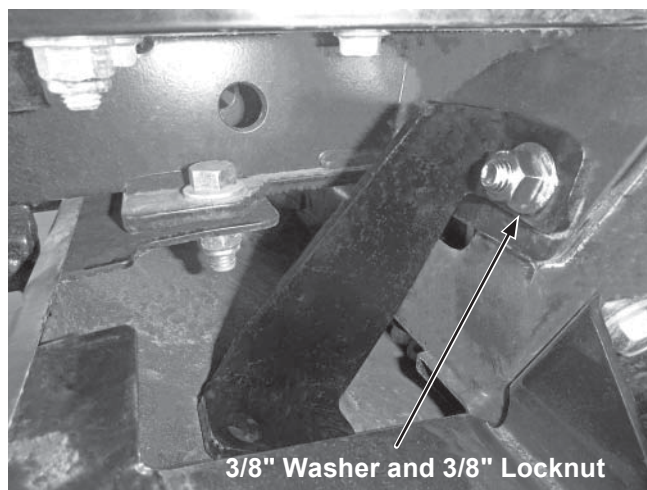

5. Repeat Steps 3 and 4 on the opposite side to install the passenger-side mount bracket.



- Position the skid plate against the lower brush guard as shown, with the fastener holes aligned. Install four 3/8" x 1-1/2" cap screws through the skid plate, brush guard, and mount brackets. Install 3/8" washers and 3/8" locknuts to the cap screws and hand tighten.

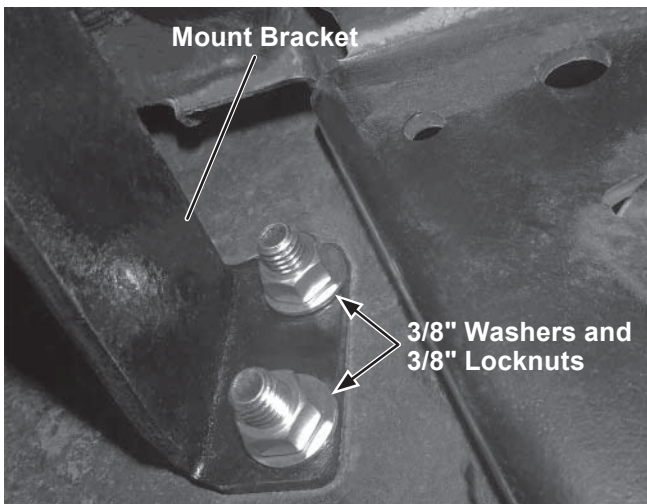
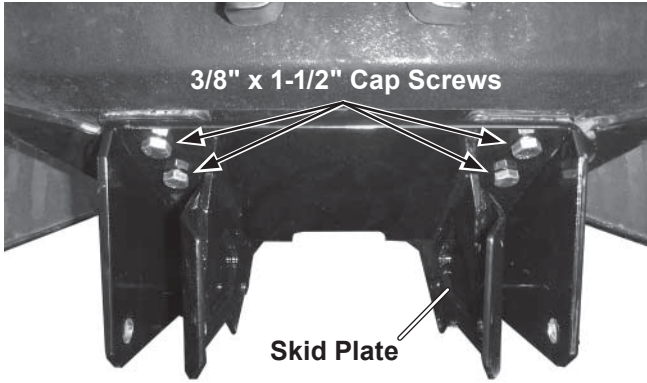

- Clamp the rear of the skid plate assembly to the vehicle frame. Adjust as necessary so that the skid plate is centered. Tighten all fasteners installed above according to the torque chart.

**⚠ CAUTION**

Before drilling holes, check to be sure that no vehicle wiring or other components could be damaged.

- Using the four indicated holes in the skid plate as a guide, drill 13/32" holes through the vehicle splash pan.

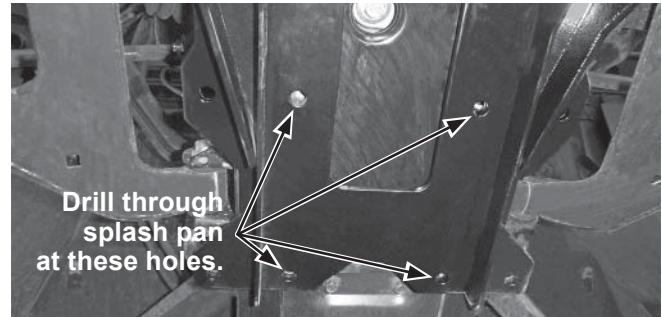

- Install the four U-bolts over the frame and through the holes in the splash pan and skid plate.

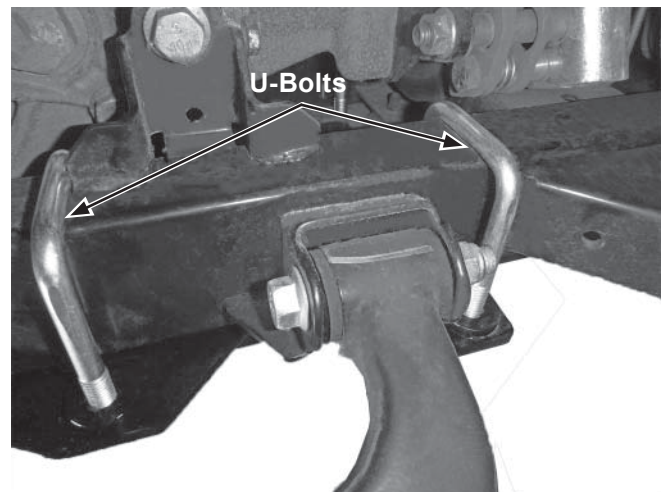

- 
10. Secure each U-bolt with two 3/8" locknuts. Tighten according to the torque chart.

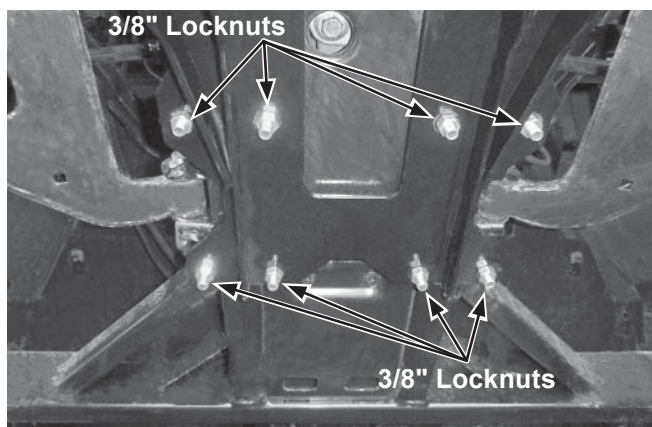

---

**NOTE:** It may be necessary to adjust the front spring preload to increase the ride height. See the vehicle owner's manual for suspension adjustment procedure.

---

---

**NOTE:** After five to ten hours of snowplow usage, retorque all mount assembly fasteners.

---

The company reserves the right under its product improvement policy to change construction or design details and furnish equipment when so altered without reference to illustrations or specifications used. This equipment manufacturer or the vehicle manufacturer may require or recommend optional equipment for snow removal. Do not exceed vehicle ratings with a snowplow. The company offers a limited warranty for all snowplows and accessories. See separately printed page for this important information.

**Printed in U.S.A.**

---